

SGS



Respectfully submitted to
Gold Bullion Development Corporation

Effective Date:

May 6th 2014

Issue Date:

June 19th 2014

Prepared by:

Claude Duplessis, Eng.

Gilbert Rousseau, Eng.

Jonathan Gagné, Eng.

Martin Stapinsky, P.Geo.,M.Sc.,Ph.D.

SGS Canada Inc.

Minerals Services

10 boul. de la Seigneurie Est, Suite 203, Blainville, Québec Canada, J7C3V5
t (450) 433 1050 f (450) 433 1048 www.geostat.com www.sgs.com

Member of SGS Group (SGS SA)

Table of Contents

1	SUMMARY	1
1.1	PROPERTY DESCRIPTION AND OWNERSHIP	1
1.2	SCOPE OF WORK	1
1.3	GEOLOGY AND MINERALIZATION	1
1.4	EXPLORATION AND DRILLING	2
1.5	HISTORICAL TAILINGS AND WASTE PILE	3
1.6	MINERAL PROCESSING, METALLURGICAL TESTING AND RECOVERY METHODS	3
1.7	MINERAL RESOURCES ESTIMATES	4
1.8	MINERAL RESERVES ESTIMATES	6
1.9	MINING	6
1.10	MANPOWER REQUIREMENT	8
1.11	ORE LOADING AND TRANSPORT	8
1.12	ENVIRONMENTAL STUDIES, PERMITTING AND SOCIAL OR COMMUNITY IMPACT	9
1.13	CAPITAL COSTS	10
1.14	SUSTAINING CAPITAL COSTS	11
1.15	OPERATING COSTS	11
1.16	ECONOMIC ANALYSIS	12
1.17	OTHER RELEVANT DATA (PROJECT SCHEDULE)	15
1.18	INTERPRETATION AND CONCLUSIONS	15
	1.18.1 Conclusions regarding the estimation of mineral resources	15
	1.18.2 Mineral Reserve Estimates	16
	1.18.3 Mining Methods	16
	1.18.4 Economic analysis	17
1.19	RECOMMENDATIONS	17
	1.19.1 Recommendations regarding the estimation of mineral resources	17
	1.19.2 Mining	18
2	INTRODUCTION	19
2.1	MINERAL RESOURCE ESTIMATION	19
2.2	PREFEASIBILITY STUDY (PFS) REPORT	19
2.3	TERMS OF REFERENCE	20
2.4	SOURCE OF INFORMATION	21
2.5	SITE VISIT	22
2.6	EFFECTIVE DATE AND DECLARATION	23
2.7	DISCLAIMER	23
3	RELIANCE ON OTHER EXPERTS	24

4	PROPERTY DESCRIPTION AND LOCATION.....	25
4.1	PROPERTY LOCATION.....	25
4.2	PROPERTY DESCRIPTION AND OWNERSHIP.....	25
5	ACCESSIBILITY, CLIMATE, LOCAL RESOURCES, INFRASTRUCTURE AND PHYSIOGRAPHY.....	39
5.1	TOPOGRAPHY & PHYSIOGRAPHY.....	39
5.2	ACCESS.....	39
5.3	CLIMATE.....	40
5.4	INFRASTRUCTURES.....	40
6	HISTORY.....	42
7	GEOLOGICAL SETTING AND MINERALIZATION.....	50
7.1	REGIONAL.....	50
7.2	LOCAL.....	51
7.3	PROPERTY.....	55
7.4	MINERALIZATION.....	56
	7.4.1 General.....	56
	7.4.2 Description of more relevant veins as per historical works.....	56
	7.4.3 The new approach – the GBB approach.....	57
8	DEPOSIT TYPES.....	61
9	EXPLORATION.....	62
9.1	GEOLOGICAL & STRUCTURAL STUDY BY EARTHMETRIX.....	62
9.2	BULK SAMPLE 2007.....	65
9.3	EXPLORATION 2007 – 2012.....	66
9.4	EXPLORATION 2013.....	66
10	DRILLING.....	68
10.1	PHASE 1.....	68
10.2	PHASE 2/PHASE 3 DRILLING.....	69
10.3	2012 DRILLING PROGRAM - NORTH AND WEST EXTENSION 2012 PROJECT.....	75
10.4	CORE RECOVERY.....	89
11	SAMPLE PREPARATION, ANALYSES AND SECURITY.....	90
11.1	CONTEXT.....	90
11.2	DRILL CORE SAMPLING PROTOCOL.....	90
11.3	CHANNEL SAMPLING PROTOCOL.....	91
11.4	ANALYSES.....	91
11.5	QUALITY ASSURANCE/QUALITY CONTROL (QA/QC) PROGRAM.....	92
11.6	SECURITY.....	93
11.7	QAQC PROGRAM 2012.....	94

11.7.1 Analytical Standards.....	94
11.7.2 Analytical Blanks	100
11.7.3 Core Duplicates.....	101
11.8 SECURITY	106
12 DATA VERIFICATION	107
12.1 THE INDEPENDENT ANALYTICAL PROGRAM	107
12.1.1 The database	107
12.1.2 Database Validation 2014	108
12.1.3 The pulp	108
12.1.4 The core	109
12.1.5 Total gold test.....	116
13 MINERAL PROCESSING AND METALLURGICAL TESTING	124
13.1 SGS LAKEFIELD TESTWORK- PROJECT 13526-001 (DECEMBER 2011 – JANUARY 2012).....	124
13.1.1 Metallurgical Testing.....	125
13.1.2 SGS Lakefield Testwork - Project 14041-001 (March – April 2013)	126
13.1.3 Gekko Systems Pty. Limited Testwork – Report T1037 (April – July 2013).....	127
13.1.4 Unité de Recherche et de Service en Technologie Minérale (URSTM).....	128
13.2 DISCLAIMER	132
14 MINERAL RESOURCE ESTIMATES	133
14.1 RESOURCE MODEL FOR THE ROLLING START PROJECT.....	133
14.1.1 Drillhole and sample data	133
14.1.2 Geological and block modeling.....	136
14.1.3 Block grade interpolation	137
14.1.4 Resource classification.....	140
14.2 UNDERGROUND RESOURCE MODEL.....	146
14.2.1 Drillhole and sample data	146
14.2.2 Geological and block modeling.....	147
14.2.3 Compositing, statistical analysis and capping	148
14.2.4 Block grade interpolation	149
14.2.5 Resource classification.....	151
14.3 GLOBAL RESOURCES	158
14.4 CONCLUSIONS REGARDING THE ESTIMATION OF MINERAL RESOURCES	160
14.5 RECOMMENDATIONS REGARDING THE ESTIMATION OF MINERAL RESOURCES.....	161
15 MINERAL RESERVE ESTIMATES	162
16 MINING METHODS	163
16.1 OVERALL PIT SLOPE ANGLE	163

16.1.1	Overburden	163
16.1.2	Overburden Slope Configuration	164
16.1.3	Rock Slope Configuration.....	164
16.1.4	Pit Slope Parameters.....	164
16.2	PIT OPTIMIZATION PROCEDURE AND PARAMETERS.....	167
16.3	THEORETICAL PIT SHELL	168
16.4	DETAILED MINE DESIGN	169
16.5	DILUTION AND ORE LOSS.....	173
16.6	MARGINAL CUT-OFF GRADE	173
16.7	TONNES WITHIN PIT DESIGN.....	173
16.8	MINE DEVELOPMENT AND PRODUCTION SCHEDULE	174
16.9	MINE OPERATIONS.....	177
16.9.1	Drilling	177
16.9.2	Blasting.....	178
16.9.3	Fleet Requirements	178
16.9.4	Manpower Requirements	179
16.10	PIT DEWATERING	180
16.11	ORE LOADING AND TRANSPORT.....	180
16.12	OLD UNDERGROUND EXCAVATIONS.....	181
17	RECOVERY METHOD	182
17.1	GENERAL	182
17.2	ORE HANDLING – CRUSHING – GRINDING - GRAVITY	183
17.3	CARBON IN LEACH – CARBON IN PULP	184
17.4	CARBON ELUTION – REFINING.....	184
17.5	CYANIDE DESTRUCTION – DESULFURIZATION - TAILINGS.....	184
17.6	GOLD RECOVERY.....	184
17.7	GOLD PRODUCTION SETTLEMENT	184
18	PROJECT INFRASTRUCTURE	185
18.1	PROCESSING FACILITIES	185
18.2	OFFICES	185
18.3	MECHANICAL GARAGE	186
18.4	WAREHOUSE/LAYDOWN YARD	187
18.5	POWERLINE.....	187
18.6	EXPLOSIVES MAGAZINES	188
18.7	FUEL FARM	188
18.8	ON-SITE ROADS	188

18.9	WASTE MATERIAL STOCKPILES	189
	18.9.1 Slope Parameters.....	189
	18.9.2 Waste Rock Stockpile.....	190
	18.9.3 Overburden Stockpile	191
	18.9.4 Slope stability analysis	192
18.10	ORE STOCKPILE PAD	194
18.11	ACCESS ROAD AND PARKING	194
18.12	WATER POND – POLISHING POND	194
18.13	WATER SUPPLY	196
19	MARKET STUDIES AND CONTRACTS	197
20	ENVIRONMENTAL STUDIES, PERMITTING AND SOCIAL OR COMMUNITY IMPACT	203
20.1	JURISDICTIONS AND APPLICABLE LAWS AND REGULATIONS	203
	20.1.1 Provincial Framework.....	203
	20.1.2 Federal Framework	206
20.2	ORE AND WASTE ROCK ENVIRONMENTAL CHARACTERIZATION	208
	20.2.1 Methodology.....	208
	20.2.2 Results	208
20.3	ENVIRONMENTAL BASELINE STUDIES	214
	20.3.1 Socio-Economic Components	214
	20.3.2 Physical Components.....	214
	20.3.3 Biological Components.....	216
20.4	MINING SITE REHABILITATION CONCEPTS.....	218
20.5	RELATIONS WITH STAKEHOLDERS	219
21	CAPITAL AND OPERATING COSTS	220
21.1	CAPITAL COSTS.....	220
	21.1.1 Working capital.....	220
	21.1.2 Pre-production salaries.....	220
	21.1.3 Overburden stripping.....	220
	21.1.4 Initial capital.....	220
21.2	SUSTAINING CAPITAL COSTS.....	221
	21.2.1 Rehabilitation and Mine Closure Capital Costs	222
	21.2.2 Overburden Stripping and others	222
21.3	OPERATIONAL COSTS.....	223
	21.3.1 Mining Cost – Hard Rock (Waste and Ore).....	223
	21.3.2 Mining Cost – Overburden.....	223
	21.3.3 Ore Loading.....	223

21.3.4 Ore Transport	224
21.3.5 Ore Crushing	224
21.3.6 Ore Processing	224
21.3.7 General and Administration (G&A)	224
21.3.8 Net Smelter Return.....	225
22 ECONOMIC ANALYSIS	226
22.1 PRINCIPAL ASSUMPTIONS	226
22.2 CASH FLOW FORECASTS	226
22.3 NET PRESENT VALUE, INTERNAL RATE OF RETURN AND PAYBACK PERIOD	227
22.4 TAXES, ROYALTIES AND INTERESTS	228
22.4.1 Taxes.....	228
22.4.2 Royalties.....	229
22.4.3 Debt and Interests	229
22.5 SENSITIVITY ANALYSIS	229
23 ADJACENT PROPERTIES	231
24 OTHER RELEVANT DATA AND INFORMATION	233
24.1 PROJECT SCHEDULE	233
25 INTERPRETATIONS AND CONCLUSIONS	234
25.1 CONCLUSIONS REGARDING THE ESTIMATION OF MINERAL RESOURCES	234
25.2 MINERAL RESERVES ESTIMATES	234
25.3 MINING METHODS	235
25.4 RECOVERY METHOD	236
25.5 ECONOMIC ANALYSIS	236
26 RECOMMENDATIONS.....	238
26.1 RECOMMENDATIONS REGARDING THE ESTIMATION OF MINERAL RESOURCES.....	238
26.2 MINING	238
26.3 RECOVERY METHOD	239
26.4 ENVIRONMENTAL STUDIES, PERMITTING AND SOCIAL OR COMMUNITY IMPACT.....	239
27 REFERENCES.....	241
ELECTRONIC REFERENCES.....	242
APPENDIX-1: CERTIFICATES OF QUALIFIED PERSON.....	243
APPENDIX-2:	248

Table of Figures

Figure 1-1: Sensitivity analysis.....	14
Figure 1-2: Project schedule.....	15
Figure 2-1: Photos of the site installations	22
Figure 2-2: Pictures of drill sites encountered during field visits 2011 & 2012.....	23
Figure 4-1: Location of Granada property: Abitibi Region, Québec.	25
Figure 4-2: Claims of the Granada property from GESTIM Québec April 14 th 2014.....	26
Figure 4-3: Location of the mining lease for which Mousseau Tremblay Inc. has 3% NSR.	27
Figure 4-4: Property with urban (green) and outdoor activities (yellow) constraint parameters	38
Figure 5-1: Satellite view from Google Earth.....	39
Figure 5-2: Air view of infrastructures looking South-East (in 2010).....	41
Figure 7-1: Geological map of the Superior Province showing the position of the Property.....	51
Figure 7-2: Regional geology (after ET91-04, MRNQ).....	51
Figure 7-3: Regional Geology Map (previous report of 2006 - from MRNQ)	52
Figure 7-4: Property Geology with claims boundary (2012) and company recent drillholes.....	53
Figure 7-5: Property Geology with claims boundary of 2012 (geology from MRNQ).....	53
Figure 7-6: Local geology from historical compilation map with GBB holes and property.....	54
Figure 7-7: Detailed mapping and geological interpretation in plan by KWG in 1992.....	55
Figure 7-8: Core reference library (partial) as prepared by previous consultants.....	56
Figure 7-9: Gold mineralization in Quartz vein.....	58
Figure 7-10: Example of visible gold occurrences at Granada	58
Figure 7-11: Cross-section (SESFT 18) showing grade continuity looking 283N with 25 m corridor.	58
Figure 7-12: Cross-section (SESFT18) with mineralized structures looking 283N with 25 m corridor.	59
Figure 7-13: Plan view of historical drift and pit #2 with trace of NNE faults in colors.	59
Figure 8-1: Outline of the mineralized conglomerate package being investigated in purple	61
Figure 8-2: Typical conglomerate S1 unit on surface.....	61
Figure 9-1: Sector where the work was performed	63
Figure 9-2: Exploration targets map from EarthMetrix Beauchastel Syenite sector	64
Figure 9-3: Exploration targets Map from EarthMetrix Adanac Extension sector	65
Figure 9-4: Channel sampling, 1 metre intervals TP-13-07	67
Figure 10-1: Layout of the phase 1 drilling campaign	68
Figure 10-2: Drilling in main Granada mine zone.....	74
Figure 10-3: Drilling east of Granada mine	75
Figure 10-4: New 2012 Diamond Drillholes Location Map on Granada Property.....	76
Figure 11-1: Permanent core racks and mobile core racks	91
Figure 11-2: Graphic of ALS internal lab standard variation from 1456 data.....	93
Figure 11-3: Standard OREAS 15d Results for Au	96
Figure 11-4: Standard OREAS 15f Results for Au	96
Figure 11-5: Standard OREAS 15h Results for Au	97
Figure 11-6: Standard OREAS 2Pd Results for Au.....	97
Figure 11-7: Standard OREAS 6Pc Results for Au.....	98
Figure 11-8: Standard Accurassay HGS1 Results for Au	98
Figure 11-9: Standard Accurassay HGS3 Results for Au	99
Figure 11-10: Blanks Analytical Results for Au	101
Figure 11-11: Flowsheet for Double Duplicate Process.....	102
Figure 11-12: Au response of 1/4 core versus duplicates 1A, 1B, 2A, 2B.....	103
Figure 11-13: Duplicate 1B versus Duplicate 1A.....	104

Figure 11-14: Duplicate 2B versus Duplicate 2A..... 105

Figure 11-15: Time-scale, Original and Duplicates overlay 105

Figure 12-1: Independent pulp selection and packing in 2011..... 109

Figure 12-2: Screenshot of comparison pulps database..... 109

Figure 12-3: Sample of the comparison database 111

Figure 12-4: Correlation between original sample and control sample half core 113

Figure 12-5: Correlation between SGS FA and SGS SM 116

Figure 14-1: Drillhole Locations and Traces used in the resource estimation 134

Figure 14-2: Drillhole phase 1 to 3 with cross section layout and property..... 134

Figure 14-3: All drillhole locations and property extent 135

Figure 14-4: Plan view of the mineralized solids including NNE-trending, sub-vertical faults 136

Figure 14-5: Cumulative Frequency diagram Au g/t of the 1 m composites 137

Figure 14-6: Variogram of 1 m Au composites Log capped at 30 g/t..... 138

Figure 14-7: Plan view of the block model cut to overburden surface 138

Figure 14-8: Ellipsoid for pass 2 of block model estimation. View looking down dip 139

Figure 14-9: Ellipse for pass 2 of block model estimation. View perpendicular to dip 139

Figure 14-10: Plan view of the mineralized solids extracted above the optimized pit shell 140

Figure 14-11: Plan view of the block model extracted above the optimized pit shell..... 141

Figure 14-12: Mineralized intervals within their respective solids. Section 11 with a 25m viewing corridor looking WNW, azimuth of 283°..... 141

Figure 14-13: Au estimation of block model. Section 11 with a 25m viewing corridor looking WNW, azimuth of 283°..... 142

Figure 14-14: Classification of block model. Section 11 with a 25m viewing corridor looking WNW, azimuth of 283° 142

Figure 14-15: Mineralized intervals within their respective solids. Section 19 with a 25m viewing corridor looking WNW, azimuth of 283°..... 143

Figure 14-16: Au estimation of block model. Section 19 with a 25m viewing corridor looking WNW, azimuth of 283°..... 143

Figure 14-17: Classification of block model. Section 19 with a 25m viewing corridor looking WNW, azimuth of 283° 144

Figure 14-18: Estimation beneath the pit to 237.5m. Section 11 with a 25m viewing corridor looking WNW, azimuth of 283°..... 144

Figure 14-19: Classification beneath the pit to 237.5m. Section 11 with a 25m viewing corridor looking WNW, azimuth of 283°..... 145

Figure 14-20: Estimation beneath the pit to 237.5m. Section 19 with a 25m viewing corridor looking WNW, azimuth of 283°..... 145

Figure 14-21: Classification beneath the pit to 237.5m. Section 19 with a 25m viewing corridor looking WNW, azimuth of 283°..... 146

Figure 14-22: Plan view of the mineralized solids including NNE-trending, sub-vertical faults 148

Figure 14-23: Cumulative Frequency diagram Au g/t of the 1 m composites 149

Figure 14-24: Variogram of 1 m Au composites Log capped at 30 g/t..... 149

Figure 14-25: Plan view of the block model cut to overburden surface 150

Figure 14-26: Ellipsoid for pass 2 of block model estimation. View looking down dip 151

Figure 14-27: Ellipse for pass 2 of block model estimation. View perpendicular to dip 151

Figure 14-28: Plan view of the mineralized solids extracted above the optimized pit shell 152

Figure 14-29: Plan view of the block model extracted above the optimized pit shell..... 153

Figure 14-30: Mineralized intervals within their respective solids. Section 11 with a 25m viewing corridor looking WNW, azimuth of 283°..... 153

Figure 14-31: Au estimation of block model. Section 11 with a 25m viewing corridor looking WNW, azimuth of 283° 154

Figure 14-32: Classification of block model. Section 11 with a 25m viewing corridor looking WNW, azimuth of 283° 154

Figure 14-33: Mineralized intervals within their respective solids. Section 19 with a 25m viewing corridor looking WNW, azimuth of 283° 155

Figure 14-34: Au estimation of block model. Section 19 with a 25m viewing corridor looking WNW, azimuth of 283° 155

Figure 14-35: Classification of block model. Section 19 with a 25m viewing corridor looking WNW, azimuth of 283° 156

Figure 14-36: Estimation beneath the depth of 237.5m. Section 11 with a 25m viewing corridor looking WNW, azimuth of 283° 156

Figure 14-37: Classification beneath the depth of 237.5m. Section 11 with a 25m viewing corridor looking WNW, azimuth of 283° 157

Figure 14-38: Estimation beneath the depth of 237.5m. Section 19 with a 25m viewing corridor looking WNW, azimuth of 283° 157

Figure 14-39: Classification beneath the depth of 237.5m. Section 19 with a 25m viewing corridor looking WNW, azimuth of 283° 158

Figure 16-1: Definition of Slope and Benching Configuration 165

Figure 16-2: Plan view with position of Cross sections 166

Figure 16-3: Typical profile of Pit number One..... 166

Figure 16-4: Typical profile of Pit number Two..... 167

Figure 16-5: 3D and Plan view of the optimized shell 169

Figure 16-6: Section view of the in-pit ramp..... 170

Figure 16-7: 3D and Plan view of the detailed pit..... 171

Figure 16-8: Various views of the detailed pit with block model..... 172

Figure 16-9: End of year 0..... 175

Figure 16-10: End of year 1..... 175

Figure 16-11: End of year 2..... 176

Figure 16-12: End of year 3..... 176

Figure 16-13: Ore transport from mine to processing plant 180

Figure 16-14: Project mining and haulage schedule..... 181

Figure 17-1: Doyon site – Surface plan..... 183

Figure 18-1: Aerial view of site layout of Granada project 185

Figure 18-2: Types of offices trailers to be acquired 186

Figure 18-3: Existing on-site infrastructures..... 186

Figure 18-4: Example of a dome type mechanical garage..... 187

Figure 18-5: Example of a 500 KVA portable sub-station 187

Figure 18-6: Example of an explosive magazine 188

Figure 18-7: Example of a fuel farm arrangement..... 188

Figure 18-8: Overburden dump profile 189

Figure 18-9: Waste Dump profiles number 1 and number 2 190

Figure 18-10: Proposed rock waste dumps locations 191

Figure 18-11: Typical section of overburden dump 192

Figure 18-12: Static slope stability analysis 193

Figure 18-13: Slope stability analysis with seismic activity and saturated overburden..... 193

Figure 18-14: Slope stability analysis with seismic activity and saturated overburden in force failure plane 194

Figure 18-15: General plan layout of Polishing pond 195

Figure 18-16: Typical section of Polishing pond..... 196

Figure 19-1: Gold price chart (2000-2014) 197

Figure 19-2: Graph and data of last three year gold price (2011) 198

Figure 19-3: Graph and data of last three year gold price (2012) 199

Figure 19-4: Graph and data of last three year gold price (2013) 200

Figure 19-5: Graph and data of last three year gold price (2014) 201

Figure 19-6: Graph of the 2014 US\$ Gold price..... 202

Figure 22-1: Sensitivity analysis 230

Figure 23-1: Map with adjacent properties (from MRN GESTIM) 231

Figure 23-2: Adjacent property Adanac project (source Threegold Resources Inc. web site)..... 232

Figure 24-1: Project Schedule 233

Figure 25-1: Sensitivity analysis 237

List of Tables

Table 1-1: In-Pit Resource using an optimal Whittle pit and a cut-off grade of 1.69 g/t* 4

Table 1-2: Resources beneath the Whittle pit to a depth of 237.5m, also applying a cut-off grade of 1.69g/t* 5

Table 1-3: Underground Resources beneath the depth of 237.5m, applying a cut-off grade of 3 g/t* 5

Table 1-4: Combined Underground Resources, beneath the Whittle pit to a depth of 237.5m, cut-off grade of 1.69 g/t* and beneath the depth of 237.5m, cut-off grade of 3 g/t* 5

Table 1-5: Granada Project Reserves (presented as mill feed) 6

Table 1-6: In-pit reserves..... 7

Table 1-7: Mine Development and Production Data 7

Table 1-8: Mining fleet..... 8

Table 1-9: Hourly and staff personnel 8

Table 1-10: CAPEX Summary..... 10

Table 1-11: Estimates cost per year of operation..... 11

Table 1-12: Mining Cost Subdivision..... 12

Table 1-13: Economic summary of base case scenario 13

Table 2-1: List of Abbreviations 21

Table 4-1: Summary of Granada claims held by the company as of March 26th, 2014 verification. 28

Table 6-1: Global classified resources at various cut-offs..... 46

Table 6-2: In-pit resources..... 47

Table 6-3: Global classified resources at various cut-offs..... 48

Table 6-4: In-pit resources..... 49

Table 10-1: Selected intersections of interest from Phase 1, Phase 2 and Phase 3 drilling 70

Table 10-2: North Extension 2012 Drilling Program - Deep and Wedged Holes 77

Table 10-3: West Extension 2012 Drilling Program 77

Table 10-4: Highlights of the 2012 DDH and the remaining Backlog Holes results 78

Table 11-1: Statistics ALS internal lab blanks 93

Table 11-2: Reference Material for Granada Project 94

Table 11-3: Summary of Analytical Results for Au in Reference Materials 95

Table 11-4: Sign Test Results for Reference Materials. 95

Table 12-1: Sign test and statistics of comparison independent core..... 112

Table 12-2: Extract of comparison sample sorted on SGS SM no grade in SM..... 113

Table 12-3: Extract of comparison sorted on SM (SGS Au Calc g/t) 114

Table 12-4: List of composite number with associated hole 117

Table 12-5: Sign test on total gold..... 123

Table 13-1: Composite head grades	124
Table 13-2: Met test results	125
Table 13-3: Wilfley test results	127
Table 13-4: Head analysis results	129
Table 13-5: ICP analysis in head sample results	129
Table 13-6: Acid generating tests results	129
Table 13-7: Gravity cyanidation test results	130
Table 13-8: Settling tests results	130
Table 13-9: Cyanide destruction test results	131
Table 13-10: Gravity Cyanidation duplicate results.....	131
Table 14-1: Block model parameters	139
Table 14-2: Classification parameters.....	140
Table 14-3: Block model parameters	150
Table 14-4: Classification parameters.....	152
Table 14-5: In-Pit Resource using an optimal Whittle pit and a cut-off grade of 1.69 g/t*	158
Table 14-6: Resources beneath the Whittle pit to a depth of 237.5m, also applying a cut-off grade of 1.69 g/t*	159
Table 14-7: Underground Resources beneath the depth of 237.5m, applying a cut-off grade of 3 g/t* ...	159
Table 14-8: Combined Underground Resources, beneath the Whittle pit to a depth of 237.5m, cut-off grade of 1.69 g/t* and beneath the depth of 237.5m, cut-off grade of 3 g/t*	160
Table 15-1: Granada Project Reserves (presented as mill feed)	162
Table 16-1: Open pit Optimization Parameters	168
Table 16-2: In-pit reserves.....	174
Table 16-3: Mine Development and Production Data	174
Table 16-4: Drilling Parameters & Assumptions.....	177
Table 16-5: Drilling data	177
Table 16-6: Blasting parameters	178
Table 16-7: Mining fleet.....	179
Table 16-8: Hourly and staff personnel	179
Table 18-1: Rock waste dumps (Stockpile) configuration	191
Table 18-2: Overburden dump configuration.....	192
Table 20-1: Environmentally Available Contents (partial digestion) – Ore.....	209
Table 20-2: Acid Mine Drainage Potential - Ore.....	210
Table 20-3: Leaching Potential - SPLP leaching Procedure 1312 - Ore.....	211
Table 20-4: Environmentally Available Contents (partial digestion) - Waste Rock	212
Table 20-5: Acid Mine Drainage Potential - Waste Rock	213
Table 20-6 : Leaching Potential - SPLP Leaching Procedure 1312 - Waste Rock.....	213
Table 21-1: CAPEX Summary.....	220
Table 21-2: Initial Capital.....	221
Table 21-3: Estimates cost per year of operation.....	222
Table 21-4: Cost for site rehabilitation and mine closure	222
Table 21-5: Mining Cost Subdivision.....	223
Table 21-6: Staff Salaries	224
Table 21-7: General costs	225
Table 22-1: Summary of the base case results.....	226
Table 22-2: Detailed cash flow statement related to the base case scenario.....	227
Table 25-1: Granada Project Reserves (presented as mill feed)	235

1 Summary

1.1 PROPERTY DESCRIPTION AND OWNERSHIP

The Granada Gold Mine property is located 5 kilometres south of the city center of Rouyn-Noranda in northwestern Quebec and 1.5 kilometers south east of the borough of Granada.

The Property is located in the municipality of Rouyn-Noranda (Granada sector) in northwestern Québec, the area is centered at 48°10' N Latitude and 79°01' W Longitude in National Topographic Map. This property comprises NTS map sheet 32D02 and 32D03.

The property covers a total area of 10061.22 ha (100.6 km²) and comprises 246 staked mining claims divided in 3 contiguous groups of 27, 98 and 121 claims, held 100% by Gold Bullion Development Corp. (TSX-V: GBB).

Claims are all in good standing with renewals at variable due dates. A total of 101 claims are up for renewal in the 2014 year, and the rest between 2015 and 2023. The claims within the Granada Property are held 100% by Gold Bullion. The mining lease BM #813 covering 21.12 hectares and BM # 852 covering 22.47 hectares have a 3% NSR payable to Mousseau Tremblay Inc.

The claims are valid for two-year periods and convey only exploration rights, no surface rights. The claims are in a good standing according to the claim system registry of Québec (Gestim). In general an average of \$1200 work in exploration for each claim is required to maintain them in good standing. An assessment report must be filed with the MERN (Ministère de l'Énergie et des Ressources naturelles) with appropriate proof of exploration expenses. Grupo Moje Ltd. is responsible for the submission of the assessment work for Gold Bullion and will be filing the assessment work.

1.2 SCOPE OF WORK

The initial PFS mandate from Gold Bullion to SGS Geostat was to prepare an on-site mill scenario; the scope of work has changed during the preparation of the study by GBB in order to bring the project into a Phase I – Open Pit with custom milling i.e. the rolling start. Gold Bullion wants to become a gold producer.

The current report presents the scenario of Phase I – Open Pit with custom milling to lamGold Westwood (former Doyon) mill in Abitibi. The scenario schedules to produce 550 tpd of ore over 3 years which should be hauled to the lamgold mill and process in batches with assistance in the preparation of the Certificate of Authorization.

1.3 GEOLOGY AND MINERALIZATION

The Granada Mine property is situated within rocks of the Temiscaming group, on the south limb of the regional east-west trending Granada synclinorium whose axial trace is located south of the Cadillac Fault. The property is underlain principally by east-west-trending, north-dipping interbedded-polymictic conglomerate, porphyry-pebble conglomerate, greywacke and siltstone-mudstone of the Granada Formation.

The Cadillac Fault traverses the northern part of the property. Within the Granada mine site itself a parallel set of shears (Granada Shear Zone) occur over a zone of 500 m in width. The shears are characterized by intense sericite, iron carbonate plus minor chlorite alteration with disseminated pyrite and arsenopyrite and host quartz veins and stringers. The veins comprise boudinaged or en-echelon quartz lenses within the

sediments and more continuous veins in the syenite intrusive bodies. A series of northeasterly trending sigmoidal faults occur between the Cadillac Fault and the Granada Shear Zone due to late shearing. This late shearing also imparted the fracturing and dilatancy in the quartz veins.

The gold mineralization is hosted by east-west trending smokey grey, fractured quartz veins and stringers. Free gold occurs at vein margins or within fractures of the quartz veins or sulphides. Late northeasterly-trending sigmoidal faults also host high grade gold mineralization. Accessory minerals include tourmaline, carbonate, chlorite, and disseminated sulphides. Pyrite is the dominant sulphide typically occurring within the immediate wall rock to the quartz veins. Minor pyrite does occur within the veins themselves. Additional sulphides such as chalcopyrite, arsenopyrite sphalerite, and galena are present in trace amounts. Fuchsite (chromium mica) is present in the immediate wall rock to the quartz veins.

The gold grade at Granada varies due to coarse free gold in the mineralized structures. Apparently discontinuous, the mineralized structures are relatively continuous; this is shown by assay grade continuity on cross section and the associated geometry of the underground workings.

The mineralized zones are being cut in blocks which are shifted in majority to the north.

In a cross-sectional view near shaft #1, the extent of the vein is over 250 m, supported by drillhole data. An important point to mention is the fact that previous operators did not extract all the gold. It is possible to see the drift projection between recent mineralized core intersections into the foot wall vein.

1.4 EXPLORATION AND DRILLING

The Granada property has been explored by Gold Bullion Development Corp. throughout the last seven years by Gold Bullion Development Corp. Geological and structural studies were done by EarthMetrix Technologies Inc. in order to determine optimal exploration targets for the discovery of significant gold mineralization on the D2D3 group of properties from available data (Assessment work files from the MRNF), structural interpretations using the technology developed by Technologies EarthMetrix Inc. by integrating all results coming from different interpretations. Maps are defined by the property limits.

A 140,000 tonnes bulk sample was processed by Gold Bullion in 2007 from an open pit at the Granada Mine, of which 30,000 tonnes were processed using an on-site mill. The average gold grade from this large sample was 1.62 g/t with a 90-percent rate gold recovery. The waste from this bulk sample, along with the waste stockpile from past bulk sampling programs at the Granada mine by previous operators were also assayed and returned an average grade of 1.75 g/t Au. This confirms the presence of gold mineralization between the vein structures, which trend east-west as one large overall structure.

In early 2013, SGS discovered shallow high grade zones using assay results from previous exploration campaigns. In May 2013, Gold Bullion Development Corporation contracted SGS Geostat to perform channel sampling on the Granada Gold property. The campaign focused on developing the newly discovered high grade zones identified in drillholes. Assays from channel samples taken from the trenched areas varied from 22.42 g/t Au over 1.04 metres to 0.01 g/t Au over 0.82 metres.

The Company has carried out three phases of exploration starting in 2009, another in 2010 and the third in 2011. All exploration work, especially drilling was completed under supervision and management of the Company's previous consultant. The drilling was done by diamond-drill using NQ core size.

- Phase 1: the company drilled 25 shallow holes from December 2009 to January 2010 at the Granada Gold Property. A total of 2,817 metres was drilled.
- Phase 2: the Company launched a 20,000 metres drill program at the Granada Gold Project in early May 2010, which was extended by 5,000 metres in September due to encouraging early results.

- Phase 3: Gold Bullion Development has completed nearly 11,000 metres of drilling at its Granada Gold Property as of January 21, 2011, with intersecting new mineralized structures throughout the LONG Bars Zone (main Granada mineralized structure package). From that drilling mineralization remains open in all directions at Granada.

The deep and shallow drilling programs were initiated in 2012 under Claude Duplessis recommendation to test structures and gold mineralization presence on the north and west extension of the Granada Property. The spring 2012 drilling program was intended to enlarge the gold mineralization envelope of the expanded LONG Bars zone resource to the north at depth and near surface to the west. A total of 8339.25 metres in 23 holes was drilled on the Granada Property in 2012.

No exploration work is present

1.5 HISTORICAL TAILINGS AND WASTE PILE

Part of the Property is recovered by historical tailings and there are tailings in one of the old open pits, now filled with water. The old tailings belong to the "Ministère de l'Énergie et des Ressources naturelles, secteur Mines" (orphan site). Gold Bullion is taking actions to take care of them in direct communication with the MERN and MDDELCC.

Regarding the onsite waste pile, legacy of previous open-pit operations, Gold Bullion can use the rock for access road construction and it is also being used by local contractors for fill. An application for a Certificate of Authorization (C of A) is underway for the use of this material. Galarneau has just received its C of A to crush and screen aggregate. He has a contract 70,000 tonnes and to the author's knowledge has a C of A for this independent operation but the Company needs another C of A for the remaining fines which is being prepared by Goldminds Geoservices with SODAVEX.

Permits for exploration drilling to the north of the property are in good standing.

The property is outside Joannès wildlife preserve located to the east. A potential risk exists with a proposed Bill n°14 (An Act respecting the development of mineral resources in keeping with the principles of sustainable development) that gives more power to Municipalities and MRC. Since these entities do not have qualified persons to review mineral projects it is one of the main concerns of the mineral industry. This situation applies to all mining and exploration projects in the Province of Québec and is not specific to the Granada property.

1.6 MINERAL PROCESSING, METALLURGICAL TESTING AND RECOVERY METHODS

Metallurgical testing done at SGS Lakefield and at the URSTM1 of Rouyn-Noranda on the Granada ore suggests that 95% gold recovery is easily attainable by gravity separation followed by cyanidation of the gravity tailings.

Since Gold Bullion (GBB) chose to have its Granada ore to be custom processed at the lamgold-Westwood mill (IMG-formerly Doyon), the ore will be transported a distance of approximately 43 km from Granada and stockpiled at Doyon. A schedule of processing from a minimum 30,000 tonnes of ore are stockpiled is in completion, actual schedule for October 2014 for 30,000 tonnes while batches in April, July and November 2015 and beyond should be in the 60,000 to 70,000 tonnes batches. lamgold will stop milling the Westwood ore to batch mill the Granada material. For the purpose of this report, batches of

¹ Unité de Recherche en Technologie Minérale is affiliated to the Quebec University in Abitibi-Témiscamingue.

35,000 tonnes are proposed at a mill feed rate of 2,400 tpd, meaning more or less 15 days of continuous runs. Because the lamgold-Doyon mill is proven to be very efficient, SGS Geostat believes that the gold recovery will be at least what was obtained at the metallurgical testing level.

Gold settlement between IMG and GBB will be done by the computation of the daily tonnage, the daily mill sampling, and the weighing and analysing of the doré bars. Moreover the mill will be surveyed and gold inventory will be taken at the beginning and end of each of the batches. However because it is not possible to avoid some ore mixing at the beginning and end of each batches, GBB an IMG will have title to and ownership of the doré bars on a pro rata basis based on the respective amounts of refined gold attributable to each of them.

1.7 MINERAL RESOURCES ESTIMATES

SGS has conducted extensive validation and database construction to prepare a reliable resource estimate for the Granada Gold project. SGS considers the resource estimate to have been reasonably prepared and to conform to the current CIM standards and definitions for estimating resources, as required under NI 43-101 “Standards of Disclosure for Mineral Projects.” Therefore, SGS accepts the public disclosure of the resource estimate as the basis for ongoing exploration at the Granada. However, the reader should be cautioned that mineral resources that are not mineral reserves do not have demonstrated economic viability.

In order to address mining underground, mineralized zones have been remodelled with 3 to 4 meters horizontal width below elevation 237.5 metres. Estimated underground mineral resources of the Granada gold project are simply obtained by adding resources in blocks with an estimated grade above any given cut-off. Resource tonnage of a block is: $2.5m \times 1.25m \times 1.25m \times 2.7t/m^3 = 10.55t$ for a full block (100% below overburden/topo surface).

In the context of re-engineering to increase robustness of the Granada project, Mineral resources have been remodeled with mineral zones having a minimum horizontal width of 7m down to elevation 237.5m. This resource model has been used for pit optimization and design for the “Rolling Start” project. This model starts from the surface and pit bottom to elevation 237.5 metres.

A cut-off grade of 1.69 g/t was used in the resource estimation and composites were capped at 30 g/t. A density of 2.7 t/m³ was used in the calculation of tonnage. The outcome is displayed in Table 1-1.

Table 1-1: In-Pit Resource using an optimal Whittle pit and a cut-off grade of 1.69 g/t*

Resource Class	Tonnes (t)	As	Au	Au
		ppm	g/t	oz
Inferred	21,000	131	5.57	3,800
Indicated	369,700	576	5.52	65,600
Measured	152,500	850	4.64	22,700
Indicated+Measured	522,200	656	5.26	88,300

*Mineral resources that are not Mineral Reserves do not have demonstrated economic viability. CM definitions were respected for mineral resources. See Reserves section (no dilution or mining loss shown here).

Tonnage beneath the Whittle surface pit to a maximum depth of 237.5 m was estimated in the same manner. The outcome is displayed in Table 1-2.

Table 1-2: Resources beneath the Whittle pit to a depth of 237.5m, also applying a cut-off grade of 1.69g/t*

Resource Class	Tonnes (t)	As	Au	Au
		ppm	g/t	oz
Inferred	33,500	1,071	6.85	7,400
Indicated	462,000	840	3.72	55,000
Measured	371,500	1,035	3.10	37,000
Indicated+Measured	833,500	927	3.44	92,250

*Mineral resources that are not Mineral Reserves do not have demonstrated economic viability. CM definitions were respected for mineral resources.

In order to address mining underground, mineralized zones have been remodeled with 3 to 4 meters horizontal width below elevation 237.5 metres. Estimated underground mineral resources of the Granada gold project are simply obtained by adding resources in blocks with an estimated grade above any given cut-off. Resource tonnage of a block is: $2.5m \times 1.25m \times 1.25m \times 2.7t/m^3 = 10.55t$ for a full block (100% below overburden/topo surface).

A cut-off grade of 3 g/t was used in the resource estimation and composites were capped at 30 g/t. A density of 2.7 t/m³ was used in the calculation of tonnage. The outcome is displayed in Table 1-3. The outcome of the combined underground (resource beneath the pit to a maximum depth of 237.5 m, CoG of 1.69 g/t, and resource beneath the depth of 237.5, CoG of 3 g/t) is displayed in Table 1-4.

Highlights include a Measured and Indicated combined underground gold resource of 325,450 ounces of gold at an average grade of 5.10 g/t gold plus 25,700 ounces Inferred at a grade of 7.14 g/t gold. The combined underground measured resource is 107,600 ounces (763,500 tonnes grading 4.38 g/t), indicated resource is 217,600 ounces (1,221,000 tonnes grading 5.54 g/t), inferred resource is 25,700 ounces gold (112,000 tonnes grading 7.14 g/t Au) using a cut-off grade of 0.40 g/t.

Table 1-3: Underground Resources beneath the depth of 237.5m, applying a cut-off grade of 3 g/t*

Resource Class	Tonnes (t)	As	Au	Au
		ppm	g/t	oz
Inferred	78,500	569	7.25	18,300
Indicated	759,000	1,306	6.66	162,600
Measured	392,000	1,024	5.60	70,600
Indicated+Measured	1,151,000	1,210	6.30	233,200

*Mineral resources that are not Mineral Reserves do not have demonstrated economic viability. CM definitions were respected for mineral resources.

Table 1-4: Combined Underground Resources, beneath the Whittle pit to a depth of 237.5m, cut-off grade of 1.69 g/t* and beneath the depth of 237.5m, cut-off grade of 3 g/t*

Resource Class	Tonnes (t)	As	Au	Au
		ppm	g/t	oz
Inferred	112,000	776	7.14	25,700
Indicated	1,221,000	1,127	5.54	217,600
Measured	763,500	1,028	4.38	107,600
Indicated+Measured	1,984,500	1,106	5.10	325,450

*Mineral resources that are not Mineral Reserves do not have demonstrated economic viability. CM definitions were respected for mineral resources.

Note and considerations: rounded numbers. The historical production of 51,476 ounces (181,744 sT @ 0.28 oz/sT) from 1930 to 1935 is included in the resource statement (cannot physically remove from measured, indicated or inferred) as the historical opening cannot be placed in 3D. Moreover, the historical mining apparently extends to the west where no mineral resources have been estimated due to impossibility to drill from old tailing surface. The author also wants to remind that grade estimations comes from Gold Bullion recent drilling, hence gold grades do not comes from historical data in the mined out sector.

1.8 MINERAL RESERVES ESTIMATES

The reserves derived from the detailed pit design have been estimated in accordance with the definitions and guidelines adopted by the Canadian Institute of Mining, Metallurgy, and Petroleum (CIM Standards on Mineral Resources and Reserves). The reserves are based entirely on measured and indicated resources and were converted as probable and proven reserves respectively.

The mineral reserves (with dilution and ore loss) is therefore equal to 569,000 tonnes of ore at an average grade of 4.24 g/t Au using cut-off grades of 1.69 g/t and represents an operation of 3.0 years. The entire reserve comprises 77,500 ounces of gold (before processing recovery). Total waste, including rock, inferred resources and overburden, is 9.3 Mt; resulting in a waste to ore ratio of 16:3. The detailed mineral reserve estimate is shown in Table 1-5:

Table 1-5: Granada Project Reserves (presented as mill feed)

Material Type		Cut-off g/t Au	Material tonnes	Grade g/t Au	Au** ounces
Ore*	Proven Reserves	1.69	170,000	3.72	20,500
	Probable Reserves	1.69	399,000	4.46	57,000
	Total	1.69	569,000	4.24	77,500

* Presented as mill feed (with 25 % mining dilution and a 10% ore loss)

** Presented as mill feed (before processing recovery)

1.9 MINING

The mining of Granada deposit will follow the standard practice of an open-pit operation with the conventional drill and blast, load and haul cycle, using a drill / truck / excavator mining fleet, and supported by a fleet of auxiliary equipment. The run-of-mine (RoM) will be drilled, blasted and loaded by hydraulic excavators and delivered by trucks to an ore stockpiling area. The ore will then be loaded onto transport trucks and delivered to the lamgold processing plant, approximately 43 km from the mine site. Waste rock material will be hauled to the waste disposal areas near the pits or backfilled into the mined pits. It has been assumed that the mining of the Granada deposit will be carried out by a mining fleet that will be leased and maintained by the Owner.

A preliminary pit optimisation was performed to outline the mineral resource that demonstrates a prospect for economical extraction. The resulting shell was then used to design a final open-pit including a ramp and safety berms. The mineral resource, which can be converted into reserve in this PFS, contained in the final pit is summarized in Table 1-6.

Table 1-6: In-pit reserves

Material Type		Cut-off g/t Au	Material tonnes	Grade g/t Au	Au** ounces
Ore*	Proven Reserves	1.69	170,000	3.72	20,500
	Probable Reserves	1.69	399,000	4.46	57,000
	Total	1.69	569,000	4.24	77,500
Waste	Overburden		840,000		
	Waste rock		8,440,000		
In-pit Total	All		9,849,000		

* Presented as mill feed (with 25 % mining dilution and a 10% ore loss)

** Presented as mill feed (before processing recovery)

A mine production schedule was prepared for the development and the operation of the Project. The mining production schedule for the open pit is based on a pre-stripping period of approximately 3 months. The results of the developed schedule are summarized in Table 1-3. Key findings include:

- Project life of 3 years, with an ore mining rate of approximately 550 tonnes per day ;
- Mill feed over the Project life of 569,000 tonnes at 4.24 g/t Au;
- Gold production of 73,600 ounces.

The following Table 1-7 is summarizing the production, the waste removal, and the average grade over the mine life.

Table 1-7: Mine Development and Production Data

		Year 0	Year 1	Year 2	Year 3	Total
Ore treated	tonnes	-	192,500	192,500	183,675	568,674
Grade	g/t	-	4.37	4.69	3.63	4.24
Processing recovery	%	-	95.00	95.00	95.00	95.00
Ounces produced	oz	-	25,669	27,556	20,361	73,585
Ore mined	tonnes	-	192,500	192,500	183,675	568,674
Overburden mined	tonnes	239,679	442,103	158,315		840,097
Waste mined	tonnes	-	2,571,864	3,449,868	2,418,110	8,439,843
Total mined	tonnes	239,679	3,206,467	3,800,683	2,601,785	9,848,614
Stripping ratio	t:t	-	15.7	18.7	13.2	16.32

The proposed schedule for the open-pit operations is based on two 8-hour shifts per day, 7 days a week and 350 days per year. The mining operations at Granada will use conventional mining methods, including drilling and blasting sequences, loading with hydraulic excavators, and hauling with off-road mining trucks. The selection of two 8-hour shifts is based mainly on the fact that this schedule will avoid any possible disturbing of the neighbourhood during the night.

The main mining fleet will consists of hydraulic excavators with a 5 tonnes bucket capacity, and 35 tonnes off-road trucks. The Table 1-8 is listing the main open-pit equipments.

Table 1-8: Mining fleet

Mining Equipment	Model (reference)	Quantity
Production drill	DrillACopco AC-ROC D55152	1
Excavator	Volvo 460	2
Excavator	CAT 336	1
Wheel loader	CAT 980H	1
Haul truck	Volvo A35 (35 tonnes)	4-7
Tractor	Cat D6 dozer	1
Water truck	To be selected (+/- 5,000 gal.)	1
Grader	Cat 12M Grader	1
Pick-ups	To be selected	5
Mechanical truck	To be selected	1

1.10 MANPOWER REQUIREMENT

The manpower requirements for the mine are divided into two categories: hourly operations and staff personnel. A full list of the personnel over the life of the mine can be seen in the Table 1-9.

Table 1-9: Hourly and staff personnel

Category		Year -1	Year 1	Year 2	Year 3
Mine - Operations	Drilling	-	3	4	3
	Blasting	-	-	1	-
	Mucking	2	6	6	6
	Hauling	6	15	24	15
	Services	2	8	8	8
Mine - Supervision & Others	Mine superintendent	1	1	1	1
	Assistant shiftboss	1	1	1	1
	Mine clerk	1	1	1	1
	Mechanic	2	6	6	6
	Mine helper	-	1	1	1
Mine Engineering	Chief engineer	1	1	1	1
	Surveyor	1	1	1	1
	Mapping technician	-	1	1	1
Geology	Chief geologist	1	1	1	1
	Assistant geologist	1	1	1	1
	Technician	1	1	1	1
Administration	Mine manager	1	1	1	1
	Administrative assistant	1	1	1	1
	Accountant clerk	1	1	1	1
	Environmental technician	1	1	1	1
	Warehouse responsible	1	1	1	1
	Human resource	1	2	2	2
	Driver	-	1	1	1
Total		26	56	67	56

1.11 ORE LOADING AND TRANSPORT

Ore material will be stockpile on-site and at the Westwood mill. A transport contractor will take care of transporting the run-of-mine ore to the selected processing plant by highway trucks (using 35 tonnes trucks). Ore material will be put on the temporary stockpile (Pad capacity of 15,000 to 20,000 t) on-site for short period of time as the main ore stockpile should be located at IMG gold milling facility (Pad capacity

between 60,000 to 70,000 t). The distance is estimated at 46 km Pad to Pad and an estimated traveling time of one hour one direction. The detailed finale schedule is not completed yet. GBB with its consultants have contacted the School board and summer camp responsible of the town of Rouyn-Noranda to address traffic time concerns. The company do not intend to haul material during the night as well as there is limited to no traffic haulage during kids arrival and departure of the Granada school. Alternative routes have been studied and the presented path is the one which meets regulations to the provincial and municipal level. The path has been studied with the technical counsel of the town of Rouyn-Noranda.

1.12 ENVIRONMENTAL STUDIES, PERMITTING AND SOCIAL OR COMMUNITY IMPACT

The design and the environmental management of the project facilities and activities will be done in accordance with this legal framework. According to the ore production rate (550 t/d) and the characteristics of the project, one certificate of authorization (CA) from the MDDELCC under Section 22 of the Environmental Quality Act, will be required in order to carry out the Granada Project.

Other permits, authorizations and approvals required include:

- authorization under Section 32 of the EQA will be needed for the treatment of potable water (including for toilets and showers) and the treatment of wastewaters,
- approval of the location of the waste dumps;
- mining lease for the small open-pit outside of GBB existing leases;
- lease for the occupation of the domain of the state for infrastructures outside of the mining leases (waste dumps, overburden dump, polishing pond);
- approval of the rehabilitation plan.

At the federal level, considering ore production rate, the Granada Project is not a designated project and it will not consequently have to go through the Canadian environmental assessment process.

Ore and waste rock material were characterized regarding environmental issues. Three (3) ore samples and eight (8) waste rock samples were selected by GBB geologists for geochemical characterization. The samples were subjected to testing to assess their metal content; metal leaching potential and acid rock drainage potential. The results of the testing indicated that waste rock is considered as «low risk», and ore is «acid generating» according to the classification of mining waste of the Directive 019. Therefore, no special measures for the protection of groundwater and surface waters are required for percolation waters from the waste dumps. A geomembrane liner will be installed at the temporary ore stockpile area in order to collect percolation waters and treat them if necessary to respect Directive 019 requirements for effluent before discharge in the environment.

Additionally, studies were carried out to collect baseline data on the physical (hydrology, hydrogeology, water and sediment quality) and biological (terrestrial and aquatic habitats; wetlands; wildlife, special-status studies; protected areas) environments. Socio-economic data were also collected on the Abitibi-Témiscamingue Administrative Region, more specifically the Granada District of the town of Rouyn-Noranda where the project is located. Description of the bio-physical and socio-economic components of the study area environment was based on information collected from various sources: field surveys; aerial photographs and/or satellite images, maps, and geomatics tools; information gathered from various governmental agencies; studies from the scientific and technical literature.

The project area considered for the project impact study extends 8 km by 8 km and is centered on the projected mine site. The most important rivers and lakes present in the project area are the Pelletier and Bruyère lakes, and the La Bruère and Beauchastel rivers. Other rivers and lakes are also present, but are of smaller size.

The project area is part of the continuous boreal forest sub-zone. The area is dominated by mixed forests (about 50%), mostly dominated by deciduous species, such as trembling aspens. The second most abundant type of stands is mixed regenerating forest (about 10%). Otherwise, white birch, black spruce

and balsam fir stands are observed. Wetlands cover about 6 % of the total project area, and already disturbed areas cover almost 8% of the territory. No special-status plant species are known to occur in the project area.

The project region is known for its diversified terrestrial and freshwater aquatic wildlife. Some species were reported in the project area with regards to special-status wildlife species (red and hoary bats, woodland caribou). The bald eagle is a species designated as vulnerable at the provincial level and is known to occur in the Pelletier Lake area. Also, the channel darter is designated as threatened species at the federal level. Finally, legally-designated wildlife habitats are located at the borders of the project area, i.e. three waterfowl gathering areas and one muskrat habitat. Those two areas are protected under the Regulation respecting wildlife habitats.

Since the project is located near the town of Rouyn-Noranda, GBB has carried out several public consultations, notably with: authorities of the town of Rouyn-Noranda, including the mayor; representatives of the Rouyn-Noranda Snowmobile Association; representatives of the Rouyn-Noranda School Board; representatives of the Rouyn-Noranda Recreation Service. Public presentations of the project have also been held. Participation of residents living in the area of the project has been important. Furthermore, an information letter has been sent to the Timiskaming First Nation Council in Notre-Dame-du-Nord, 80 km south-west of Rouyn-Noranda.

Lastly, concepts of rehabilitation have been prepared for the project. The rehabilitation plan includes mitigation measures for the remaining waste rock piles and hauls roads surfaces. Most of the mining infrastructures will be dismantled and managed according to regulatory requirements (disposed of or recycled off-site). Once the mining activities cease, the pit will gradually fill up to its equilibrium level with rainfall and groundwater. Fences will be installed around the open-pits for security purpose. Whenever possible, the surface water drainage pattern will be re-established to a condition similar to the original hydrological system.

As per to Directive 019, a monitoring program will be implemented following the mine closure to account for all the requirements specified in that Directive, especially with regards to surface and ground water quality, physical stability of the waste rock piles, and effectiveness of the re-vegetation.

1.13 CAPITAL COSTS

The total capital expenditures cost (CAPEX) is estimated at an overall accuracy of $\pm 25\%$, which is the standard for a pre-feasibility study. The CAPEX was defined by SGS using an in-house database, seller bids, and the Mine & Mill Equipment Costs Estimator's Guide: Capital & Operating Costs (2012) annexed to 2014. The total required investment is estimated at 6.70 M\$. Please refer to the Table 1-10 for the CAPEX breakdown.

Table 1-10: CAPEX Summary

Item	Cost
Working capital (3 months guarantee)	\$ 3,500,000
Pre-production salaries	\$ 600,000
Overburden stripping	\$ 601,595
Initial capital (infras and other)	\$ 1,993,750
Total	\$ 6,695,345

This capital requirement does not include:

- Costs to obtain permits;
- Any provision for changes in exchange rates;
- GST/QST;
- Project financing and interest charges;
- Price/cost escalation during construction;
- Import duties and custom fees;
- Sunk cost;
- Exploration activities;
- Severance cost for employees at the cessation of operations;
- Any additional costs (but can partly be absorbed in contingency allowance).

1.14 SUSTAINING CAPITAL COSTS

Each mining operation has to inject a certain yearly amount of investment, defined as sustaining capital costs, in order to keep its operation up and running, to respect regulations, etc. At the inverse of the CAPEX, these cost are occurring after the start of the operation. SGS estimates this sustaining capital cost to be 2.90 M\$ divided in 3 main items; financial guarantee for site rehabilitation, overburden stripping, and others. Table 1-11 outlines the estimates for the cost per year of operation.

Table 1-11: Estimates cost per year of operation

Year	1	2	3	Total
Financial guarantee for site rehabilitation	\$ 620,313	\$ 310,156	\$ 310,156	\$ 1,240,625
Overburden stripping	\$ 839,825	\$ 667,223	\$ -	\$ 1,507,047
Others (provision)	\$ 50,000	\$ 50,000	\$ 50,000	\$ 150,000
Total	\$ 1,510,137	\$ 1,027,379	\$ 360,156	\$ 2,897,672

1.15 OPERATING COSTS

Mine operating costs were calculated using a list of equipment and manpower prepared by SGS. Mining operating costs include; the leasing costs for the main mining equipments, the equipment operating cost, the salaries, the cost for blasting and other services. The equipment cost and blasting cost are based on Supplier’s budgeted price and a fuel price of C\$1.30 per liter of fuel. Average salaries are based upon a discussion between SGS and Gold Bullion Development Corporation and include an average of 30% fringe benefits. Equipment unit operating and maintenance costs were developed from quotations received from supplier cost estimation guides and from experience and personal contacts within the mining industry; other sources of information are from an internal database on similar projects. The global hard rock mining costs are summarized in the Table 1-12.

Table 1-12: Mining Cost Subdivision

Item	unit	Cost	
		Waste	Ore
Drilling	\$/t	0.40	0.79
Blasting	\$/t	0.64	1.29
Mucking	\$/t	0.49	0.49
Hauling	\$/t	1.27	1.27
Services	\$/t	0.59	0.59
Staff/others	\$/t	0.16	0.16
Total	\$	3.55	4.59

In addition to the operational mining costs, SGS calculated others operating costs defined as follow:

Mining cost – overburden:	2.51 \$/t mined
Ore loading:	1.25 \$/t of ore
Ore transport:	4.75 \$/t of ore
Ore crushing:	0.25 \$/t of ore
Ore processing + G&A:	51.00 \$/t of ore
Net smelter return:	3.00 %

1.16 ECONOMIC ANALYSIS

SGS made a numbers of assumptions in order to develop the Granada Project financial model:

- price of gold at \$1,400.00 CDN per ounce troy;
- 3.0% NSR is attributable to a third party;
- processing rate of 192,500 tonnes per year (equivalent to approximately of 550 tonnes per day);
- constant exchange rate of \$0.90 (CDN\$:US\$);
- discount rate of 5.00 %;
- sunk costs and owner's costs are not included in the model;
- 3 years of mining operation;
- initial capital cost will be spend before the first year of production (year -1 in the model);

A summary of the base case results is given in Table 1-13.

Table 1-13: Economic summary of base case scenario

Item		Unit	Value
Total revenues		\$	102,700,000
Total operating costs		\$	65,100,000
Pre-production capital costs		\$	6,700,000
Sustaining capital costs		\$	2,900,000
Royalties paid		\$	3,100,000
Pre-tax	Undiscounted benefits	\$	28,400,000
	NPV discounted at 6.00 %	\$	24,700,000
	Internal rate of return	%	169.4%
	Payback period	months	0.6
After-tax	Undiscounted benefits	\$	22,700,000
	NPV discounted at 6.00 %	\$	19,500,000
	Internal rate of return	%	136.0%
	Payback period	months	0.8

The sensitivity of the Net Present Value (NPV) and the internal rate of return (IRR) were evaluated for changes in key variables and parameters such as:

- Capital investment (CAPEX);
- Gold price;
- Operating cost;
- Head grade;
- Processing recovery.

For simplification purpose, this sensitivity was prepared using only the pre-tax values. The result of the sensitivity is presented by the Figure 1-1:

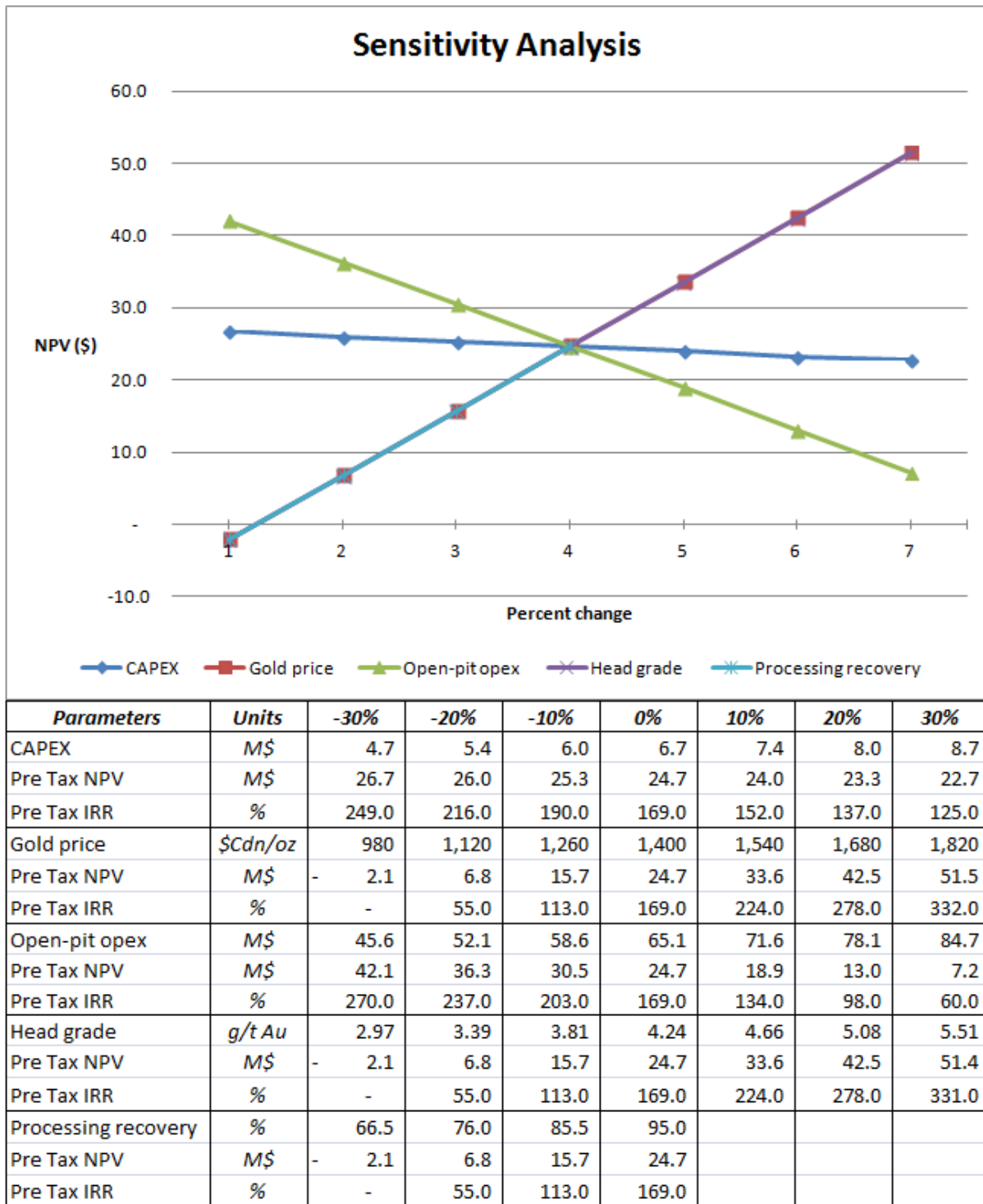

Figure 1-1: Sensitivity analysis

It can be seen that the gold price, the head grade and the processing recovery have the greatest impact on project NPV and IRR. The project becomes uneconomic when the gold price, the head grade, or the processing recovery drops by about 27.5 %. Overall, the project is sensitive to each of the major variables. This sensitivity analysis clearly demonstrates that the gold price needs to remain over 1,000 \$CDN/oz troy; in order to keep the project economically viable.

1.17 OTHER RELEVANT DATA (PROJECT SCHEDULE)

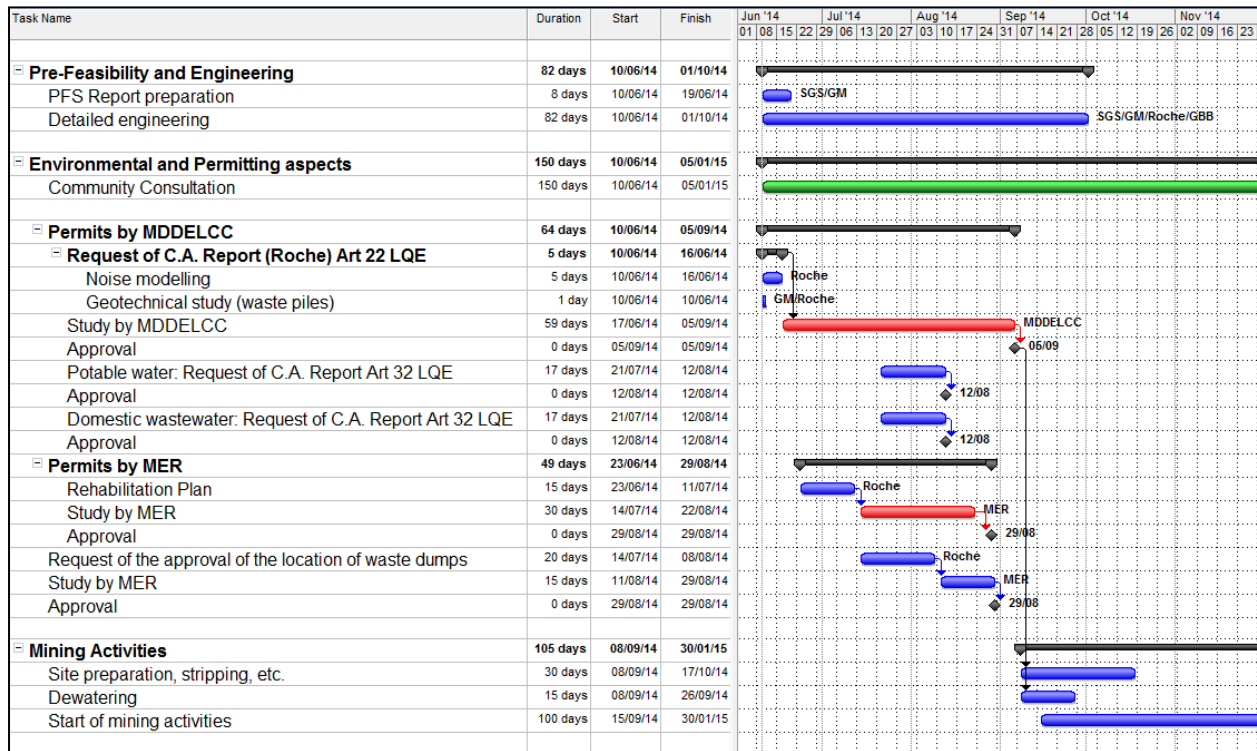

Figure 1-2: Project schedule

1.18 INTERPRETATION AND CONCLUSIONS

1.18.1 CONCLUSIONS REGARDING THE ESTIMATION OF MINERAL RESOURCES

In the context of re-engineering to increase robustness of the Granada project, Mineral resources have been remodelled with mineral zones having a minimum horizontal width of 7m down to elevation 237.5m. This resource model has been used for pit optimization and design for the “Rolling Start” project. This model starts from the surface and pit bottom to elevation 237.5 metres. Lower grade is now excluded from the mineral resource statement. No gold loss has occurred from the PEA resource model to the actual presentation. It is all a matter of the mineral cut-off grade used with the associated economic scenario.

In order to address mining underground, mineralized zones have been remodelled with 3 to 4 meters horizontal width below elevation 237.5 metres. Highlights include a Measured and Indicated combined underground gold resource of 325,450 ounces of gold at an average grade of 5.10 g/t gold plus 25,700 ounces Inferred at a grade of 7.14 g/t gold. The combined underground measured resource is 107,600 ounces (763,500 tonnes grading 4.38 g/t), indicated resource is 217,600 ounces (1,221,000 tonnes grading 5.54 g/t), inferred resource is 25,700 ounces gold (112,000 tonnes grading 7.14 g/t Au) using a cut-off grade of 0.40 g/t.

Previous small open pits have been taken into account and are starting surfaces of optimization. The historical production of 51,476 ounces (181,744 sT @ 0.28 oz/sT) from 1930 to 1935 is included in the resource statement and the author cannot physically remove it from the measured, indicated or inferred categories. As the historical opening cannot be placed in 3D. Moreover the historical mining apparently

extent to the west where no mineral resources have been estimated due to impossibility to drill from old tailing surface. The author also wants to remind that grade estimations comes from Gold Bullion recent drilling, hence gold grades do not comes from historical data in the mined out sector.

- Accuracy of the disclosure on what has been mined out underground. The amount of material mined out is limited, however it could be a bit more than disclosed but not to a huge extent since it would be reflected with a much larger tailing footprint.
- Combination of additional factors which could materially affect the resources are:
 - The presence of old orphan tailings
 - The presence of arsenic in the rock at Granada

1.18.2 MINERAL RESERVE ESTIMATES

The mineral reserve (with dilution and ore loss) is equal to 569,000 tonnes of ore at an average grade of 4.24 g/t Au using cut-off grades of 1.69 g/t and represents an operation of 3.0 years. The entire reserve comprises 77,500 ounces of gold (before processing recovery). This reserve is dated to the effective date of this report. Reserves are based on a cut-off grade and there is always a possibility that the cut-off grade varies over time. The majors factors that could affect the cut-off grade, and thus directly the ore reserves, are a change in the gold price, a change in the processing recovery, a change in the operating costs (such as processing, G&A, transport, etc.), a different mining dilution that the one used in this report, etc.

1.18.3 MINING METHODS

As describe previously in this section, the mining of Granada deposit will follow the standard practice of an open-pit operation with the conventional drill and blast, load and haul cycle, using a drill / truck / excavator mining fleet, and supported by a fleet of auxiliary equipment. The run-of-mine (RoM) will be drilled, blasted and loaded by hydraulic excavators and delivered by trucks to an ore stockpiling area. The ore will then be loaded onto transport trucks and delivered to the lamgold processing plant, approximately 43 km from the mine site while the waste rock material will be hauled to the waste disposal areas near the pits or backfilled into the mined pits.

During this study, SGS came to the conclusion that the riskier item associated to mining is the control of the mining dilution during the operations. The ore zones are relatively thin following a 45-55 degrees dip and are favorable to an important dilution. In this study, SGS estimated the dilution to 25% at a gold grade of 0.00 g/t. Based on our experience and on similar operations, these estimates are judged acceptable but a considerable effort will be required during the operations to achieve these values. The effect of an increase in mining dilution is to lower the average mill feed grade and directly affect the project profitability. As is can be seen in the sensitivity analysis, the overall project profitability is extremely sensitive to the mill feed grade. SGS recommends to pursue the analysis of calculating the mining dilution during a feasibility study by considering various approaches such as lower the height of the benches in ore material, do in-fill drilling, increase the assaying of the ore zones, control and follow the ore blasts movements, etc.

Another aspect that requires attention is the old underground openings. It has been since 1930 that the Granada project is sporadically mined. Consequently, old underground excavations are present and need to be considered if mining is re-started. The first pit is in a Greenfield zone where no underground mining has proceed. It is scheduled to proceed with 3D scanning of openings and survey once water level allows access to the openings. Old underground drift location have been put in plan but exact position are not considered exact for the mining operation and the company should complete a detailed survey once access is possible using laser scanner, surface survey with GPR to model openings. Procedures will have to be put in place for the accurate survey of the openings before getting into their vicinity. As the mining width of the old time is relatively thin and no huge openings are present in documents, the procedure should be relatively simple and limited ore drop to the level should occur. It is important to mention that as

per existing information only a portion of the bottom of the pit to the west should cross small underground openings.

1.18.4 ECONOMIC ANALYSIS

The financial analysis of the Granada Project for the base case scenario demonstrates the profitability of the project using the assumptions made in this report with a pre-tax NPV of 24.7 M\$ and a pre-tax IRR of 169%. However, there is always a possibility that such values vary more or less, and thus depending on several factors as has been shown in the sensitivity analysis. It is important to remember that the project is very sensitive to the gold price, the head grade and to the processing recovery. As per example, if one of these values varies by +27.5 % or by -27.5 %, the project NPV became 49.2 M\$ and 0.0 M\$ respectively.

Note: At the moment of completing this report, final discussions on the custom milling agreement were underway. In the author’s opinion (Claude Duplessis, Eng.) who have participate in providing the technical information between the parties and continuous discussions between responsible of IMG & GBB, there is actually no reason to believe that the custom milling agreement between IMG & GBB should not take place and believe it should be signed within the next 2 to 3 weeks to the latest.

1.19 RECOMMENDATIONS

1.19.1 RECOMMENDATIONS REGARDING THE ESTIMATION OF MINERAL RESOURCES

It is recommended to undertake negotiation and clean-up of the orphan tailings (dating from 1935) with the Ministry of Natural Resources Quebec in order to enable exploration drilling to the northwest of existing drilling to validate extension of the mineralized package at depth (old tailings location). It is also recommended to do additional drilling to improve resource estimates in the open pit area lateral extension. It is also recommended to complete the drilling to the west, to the north and to the east on a 40 to 50 m grid of surface holes drilling southward at 55 degrees dip. A few infill holes where gap exists and 3 cross-sections of 3 holes on 100 m line to tests mineralization on the claims to the west. There are 3 target depths which merit additional drilling. One is near surface which we can define as 0-100, from 100 to 400 meters and deeper which is 400 to 1000 meters vertical depth, The deep drilling of 2012, the DUP holes have confirmed extension of gold mineralisation at 1Km vertical depth showing the system is still open. The author also wants to mention that the property has not been explored extensively by diamond drilling and some budget should be put on testing extensions when the economic conditions allows for that type of work.

The exploration work program & others – Step 1 – 2014/2015 is estimated as follow:

Exploration Budget on the Granada Project (CAN\$)

Trenching (exploration)	\$75,000
Drilling (definition, exploration (0-400m))	\$2,500,000
Geotech Drilling (try to increase pit slope)	\$75,000
Laboratory met testings	\$50,000
Supervision and Technical reports	\$150,000
Deep drilling program Phase 2 targeting mineralization depth (400-1000m)	\$5,000,000
<u>Estimated total cost</u>	<u>\$7,850,000</u>



1.19.2 MINING

The Granada PFS is comprised of mining work that has been selected, designed and estimated in a way to meet industry standards. For this level of study, SGS has provided a mining plan for the future operation. SGS has provided a list of recommendations, which would be beneficial if contemplated during detailed engineering phase. These mining engineered recommendations include:

- Developing strategic mine schedule in short-term detail (quarterly, monthly);
- Identifying opportunities for in-pit dumping;
- Review the estimation of the mining dilution and ore loss with a detailed mining approach for ore material;
- Complete a geotechnical study to optimize the open-pit slopes;
- Perform trade-off study for mining equipment selection and size;
- Consider the underground mining method as a serious alternative;
- Perform trade-off study to outline the optimal transition between open-pit and underground mining.

The authors recommend to Gold Bullion to proceed with the development of the project conditional to the recommended program of work which includes: definition and geotechnical drilling specific to the pit, in addition to the detailed engineering while permitting process takes place.

2 Introduction

The Granada Gold Project is located in Abitibi, 5 km south of the city of Rouyn-Noranda, Québec. This NI 43-101 Report was prepared by SGS Geostat for Gold Bullion Development Corporation for the Phase I – Open Pit project. It includes information from the update of the Mineral Resources which was completed and filed on May 06rd 2014, portion of the Preliminary Economic Assessment PEA study completed on February 2013 and all information from then to now. The mineral resource model has been redone in the Phase I open pit custom milling scenario which is also named the rolling start.

2.1 MINERAL RESOURCE ESTIMATION

This technical report was prepared by SGS Canada Inc. – Geostat (“SGS Geostat”) for Gold Bullion Development Corporation (“Gold Bullion”) to support the disclosure of mineral resources for the Granada property (“Property” or “Project”). The report describes the basis and methodology used for modelling and estimation of the Granada gold deposit located on the property from drillholes completed by Gold Bullion during the 2009, 2010, 2011 and 2012 exploration programs (data received and validated on cut-off date of November 7th 2012). The report also presents a review of the history, geology, sample preparation and analysis, and data verification of the project. The report also provides recommendations for future work.

SGS Geostat was initially commissioned by Gold Bullion in 2011 to prepare an independent estimate of the mineral resources of the Granada deposit and in 2012 for an update of resources with remaining back log and new drilling of 2012 under SGS Geostat staff supervision.

The reader must be advised that the content of this technical report is an update of the previously filed report on February 4nd 2013. Some sections remain the same and the new information has been added in the respective sections.

The mineral resource estimates prepared in the PEA were aiming at a high tonnage low grade scenario with an on-site mill with low selectivity. As market conditions were deteriorating and gold price were getting lower, GBB management asked SGS Geostat to prepare a rolling start open pit scenario Phase I capable to support adverse market conditions and relatively low gold price. This has required the remodelling of the mineral resources for higher selectivity with higher grade zones, leaving behind low grade mineralisation which was included in the previous PEA disclosure.

2.2 PREFEASIBILITY STUDY (PFS) REPORT

Following the completion of the updated mineral resource report, Gold Bullion Development Corporation (“Gold Bullion”) has mandated SGS Canada Inc. – Geostat (SGS Geostat) to complete a PEA study compliant to NI 43-101 including a Technical Report (The Report) in 2013. This report was based on the assumptions that the Granada gold deposit could be put in production at a rate of 7,500 tonnes per day over a period of 11years. An on-site concentrator with gravity-cyanidation processing was included in the economic study.

Production was to come from an open pit designed to supply 6,500 tonnes per day (tpd) and an underground (U/G) mine supplying 1,000 tpd. The underground operation was planned to operate from a main ramp only, avoiding the cost of sinking a shaft. Two mining methods were proposed for the UG production, both as variants of the Cut-and-Fill methods. The economic results were shown in an annual cash flow with NPV discounted at 5.5%, sensitivity analysis, IRR, and payback period were also included in the report. This 2013 PEA Technical Report was filled on February 2013.

The current report presents the scenario of Phase I – Open Pit with custom milling to lamGold Westwood (former Doyon) mill in Abitibi. The scenario schedules to produce 550 tpd of ore over 3 years which should be hauled to the lamgold mill and process in batches.

2.3 TERMS OF REFERENCE

The PFS report Phase I – Open Pit Granada Gold Project was prepared by Claude Duplessis Eng., Mr. Gilbert Rousseau Eng., and Jonathan Gagné, Eng.

Mr. Claude Duplessis Eng. and Mr. Gilbert Rousseau Eng. who was responsible for the sections 13 and 17 of this report, have both visited the site on November 2th and 3rd 2011. Mr. Duplessis visited the site for the independent sampling with Karina Sarabia GIT, Amanda Landriault GIT, Jean-Philippe Paiement GIT and Matthew Halliday GIT from November 27th to December 2nd in 2011 who contributed to the preparation of the first technical report. Mr. Duplessis also visited the site on March 14th, mid- April and June 20th 2012. In 2013, Mr Duplessis visited the site on April 30th to May 2nd, from June 13th to 15th, from October 1st to 2nd. In 2014, Mr Duplessis visited the site on January 12th to 14th, on January 24th, on February 13 to 14th, on February 26th to 28th and on May 20th to 24th. Mr Duplessis is responsible for the data verification and validation, geological modelling, resource estimates and sections 1-27 of this PFS report. The Property was visited for a review of exploration methodology, sampling procedures, drill site inspection, wedge supervision and to conduct inspection of selected mineralized drill intervals. Jonathan Gagné, Eng., qualified person, visited the property on December 21st 2012 and on October 4th 2013, and is responsible for the sections 15, 16 (at the exception of 16.1), 18, 21, and 22 of this report. Martin Stapinski, P.Geo., M.Sc., Ph.D., from Roche Ltd. did not visit the property and is responsible for the section 20 of this report.

The initial PFS mandate from Gold Bullion to SGS Geostat was to prepare an on-site mill scenario; the scope of work has changed during the preparation of the study by GBB in order to bring the project into a Phase I – Open Pit with custom milling i.e. the rolling start. Gold Bullion wants to become a gold producer.

This technical report was prepared according to the guidelines set under “Form 43-101F1 Technical Report” of National Instrument 43-101 Standards and Disclosure for Mineral Projects. The certificate of qualification for the Qualified Persons responsible for this technical report have been supplied to Gold Bullion as separate documents and can also be found at the very end of the report.

All measurements in this report are presented in “International System of Units” (SI) metric units, including metric tonnes (tonnes) or grams (g) for weight, metres (m) or kilometres (km) for distance, hectare (ha) for area, and cubic metres (m³) for volume. All currency amounts are Canadian Dollars (\$) unless otherwise stated. Abbreviations used in this report are listed in Table 2-1.

Table 2-1: List of Abbreviations

tonnes or t	Metric tonnes
kg	Kilograms
g	Grams
km	Kilometres
m	Metres
µm	Micrometres
ha	Hectares
m ³	Cubic metres
km/h	Kilometre per hour
%	Percent sign
t/m ³	Tonnes per cubic metre
\$	Canadian Dollars
°	Degree
°C	Degree Celcius
NSR	Net smelter return
ppm	Parts per million
ppb	Parts per billion
NQ	Drill core size (4.8 cm in diameter)
SG	Specific Gravity
NTS	National Topographic System
UTM	Universal Transverse Mercator
NAD	North America Datum
Ga	Billion years
Au	Gold
g/t	Gram per metric tonne
Oz	Ounce
Moz	Million ounces
SM	Screen Metallic
FA	Fire Assay
Ma	Million years

2.4 SOURCE OF INFORMATION

The information comes from the previous technical report and the new information was developed during SGS Geostat deep hole drilling program and the western extension drilling campaign in 2012.

Drillholes were surveyed by Mazac independent surveyor.

Historical holes were integrated into the database in 2012, however decision was made by the author not to use the historical data of the 90's for resource estimation since drill cores were not sampled in full and it was not possible to carry a QA/QC program at this stage and significant difference in holes elevation was observed. Moreover, the new Gold Bullion drilling program covered the 90's drilling area and much more. Only one historic hole (90-01) to the north west was used to complete information between new deep drilling and the intensively drilled area.

Information in this report is based on critical review of the documents, information and maps provided by the personnel of Gold Bullion and independent 3rd parties like commercial laboratories, Quebec Ministry of Natural Resources and surveyors.

2.5 SITE VISIT

Claude Duplessis, Eng., qualified person, visited the site on November 2nd and 3rd 2011 and from November 27th to December 2nd of the same year, he also visited the property on March 14th, mid-April and July 4th 2012. In 2013, Mr Duplessis visited the site on April 30th to May 2nd, from June 13th to 15th, from October 1st to 2nd. In 2014, Mr Duplessis visited the site on January 12th to 14th, on January 24th, on February 13 to 14th, on February 26th to 28th and on May 20th to 24th.

Gilbert Rousseau, Eng., qualified person, visited the property on November 2nd and 3rd 2011.

Jonathan Gagné, Eng., qualified person, visited the property on December 21st 2012 and on October 4th 2013.

The personal inspections were positive; the work sites were clean and well maintained. Gold Bullion core shack and core splitting facilities were in good conditions. The drill cores are stored in covered core racks (Figure 2-1). The rejects and pulps are stored in containers. The site is constantly monitored.



Building with core logging and cutting facility



Core boxes in racks and on steel carrier

Figure 2-1: Photos of the site installations



Drill site with identified casing 2011 pit fence in the back



Identified casing 2011 campaign (GR-11-255)



Drill setting-up on western extension 2012

Drill pad site along the access road 2012

Figure 2-2: Pictures of drill sites encountered during field visits 2011 & 2012

2.6 EFFECTIVE DATE AND DECLARATION

The present NI 43-101 Prefeasibility Study (PFS) Phase I – Open Pit Granada Gold Project is considered effective as of May 6, 2014 and is the support of the Gold Bullion Development Corp press release of the same date, and entitled: “GOLD BULLION RECEIVES POSITIVE PRE-FEASIBILITY STUDY FOR THE ROLLING START TO GOLD PRODUCTION AT GRANADA”

2.7 DISCLAIMER

It should be understood that the mineral resources which are not mineral reserves do not have demonstrated economic viability. The mineral resources presented in this Technical Report are estimates based on available sampling and on assumptions and parameters available to the Authors.

The comments in this PFS Technical Report reflect the Authors’ and SGS Geostat best judgment in light of the information available.

3 Reliance on Other Experts

The authors of this technical report are not qualified to comment on issues related to legal agreements, royalties, permitting, taxation and environmental matters. The authors have relied upon the representations and documentations supplied by the Company management and third parties. The authors have reviewed the mining titles, their status, the legal agreements and technical data supplied by Gold Bullion Development Corp, and public sources of relevant technical information.

As for common metals, precious metal like Gold is sold on public exchanges and evaluating their prices is relatively straightforward. Prices of metals tend to fluctuate strongly due to 1) market conditions; 2) European & USA debt crisis; 3) speculation as to the future demand. For this study metal prices were derived from a three year weighted average obtained from index Mundi.

<http://www.indexmundi.com/commodities/?commodity=gold&months=60>

Comparisons were made with other recent technical reports and price assumptions available which showed that the price assumptions were well within range of other experts. These prices were used to establish a minimum cut-off grade for the Gold.

The author relies on independent surveyor (Mazac Geoservice inc.) for the accuracy of the diamond drillhole positions and gyroscopic down-hole orientation surveys for the deep holes.

The author relies on the commercial Laboratories used for the assays results. On the taxation portion, the author relies on Mrs. Lucie Chouinard, M. Fisc., CPA, CA Associée / Fiscalité from Deloitte Rouyn-Noranda office.

4 Property Description and Location

4.1 PROPERTY LOCATION

The Granada Gold Mine property is located 5 kilometres south of the city center of Rouyn-Noranda in northwestern Québec and 1.5 kilometres south east of the borough of Granada.

The Property is located in the municipality of Rouyn-Noranda (Granada sector) in northwestern Québec, the area is centered at 48°10' N Latitude and 79°01' W Longitude in National Topographic Map. This property comprises NTS map sheet 32D02 and 32D03.

Figure 4-1 presents the location of the property in the regional context (source from Gold Bullion Web site).

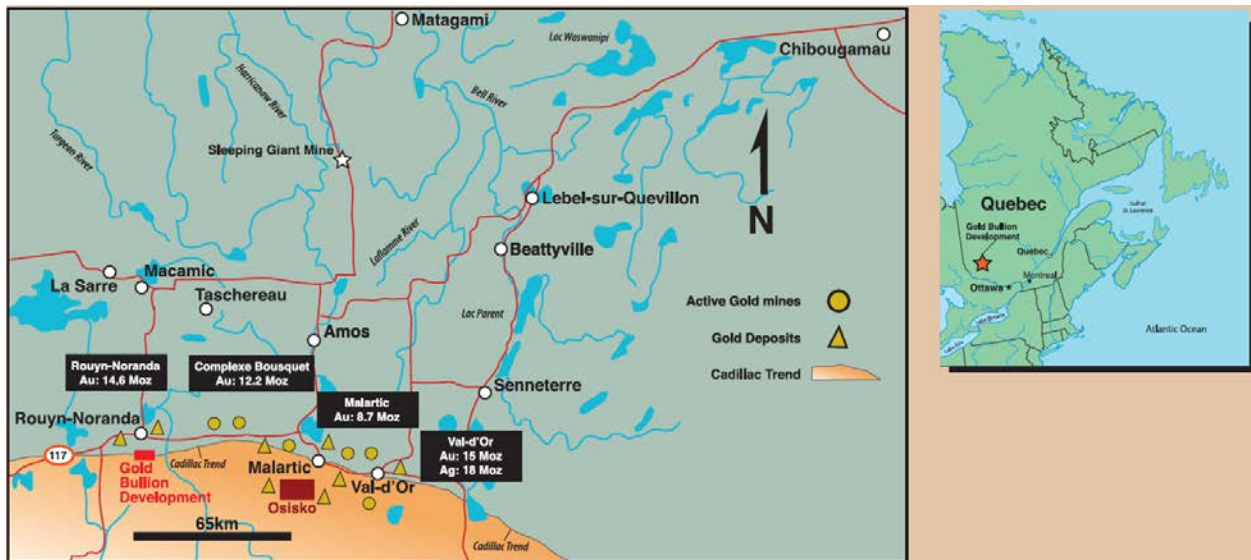

Figure 4-1: Location of Granada property: Abitibi Region, Québec.

4.2 PROPERTY DESCRIPTION AND OWNERSHIP

The property covers a total area of 10061.22 ha (100.6 km²) and comprises 246 staked mining claims divided in 3 contiguous groups of 27, 98 and 121 claims, held 100% by Gold Bullion Development Corp. (TSX-V: GBB). Map-staked claim is a claim giving the holder the exclusive right to explore for minerals in the area shown in Figure 4-2.

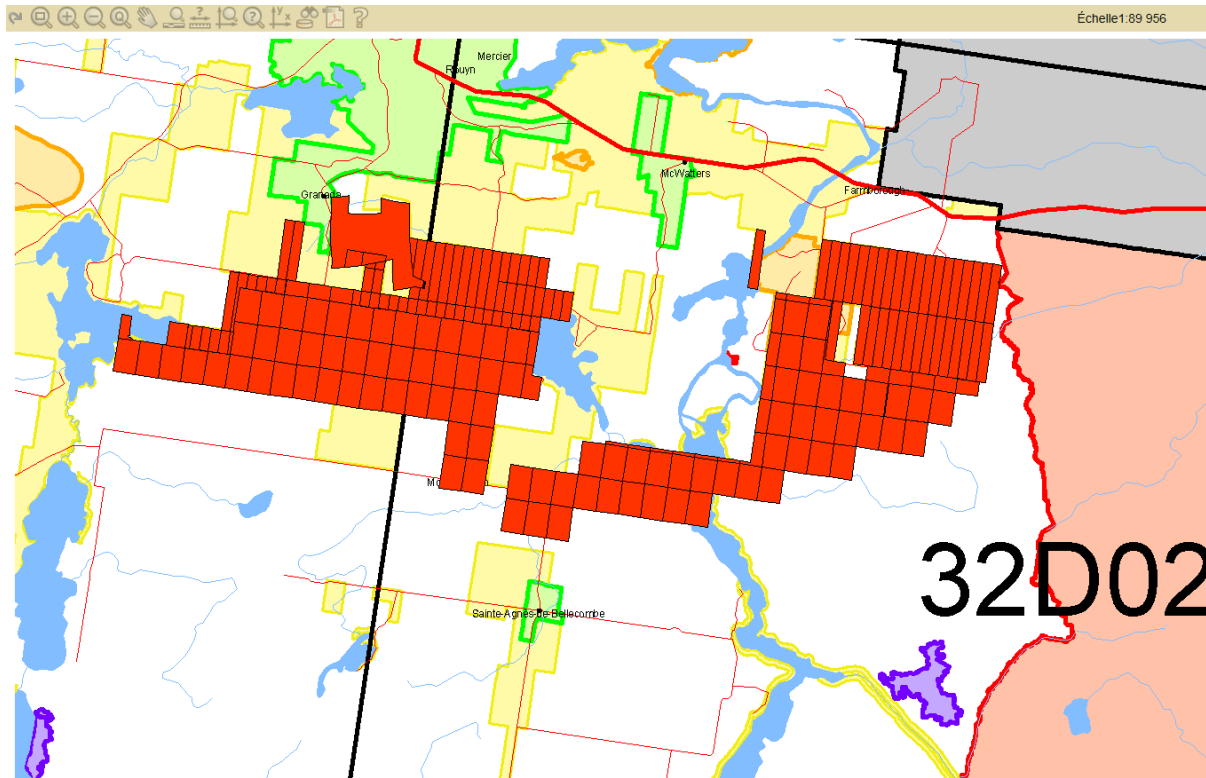

Figure 4-2: Claims of the Granada property from GESTIM Québec April 14th 2014.

Claims are all in good standing with renewals at variable due dates. A total of 101 claims are up for renewal in the 2014 year, and the rest between 2015 and 2023. The claims within the Granada Property are held 100% by Gold Bullion. The mining lease BM #813 covering 21.12 hectares and BM # 852 covering 22.47 hectares have a 3% NSR payable to Mousseau Tremblay Inc. The detailed definition of the NSR could not be verified by the author, the author has no confirmation the NSR is registered to the MRN. The locations of these Mining Leases as per MRN Gestim system are presented in the following Figure 4-3.

There are no additional royalties to the author's knowledge.

The claims are valid for two-year periods and convey only exploration rights, no surface rights. The claims are in a good standing according to the claim system registry of Québec (Gestim). In general an average of \$1200 work in exploration for each claim is required to maintain them in good standing. An assessment report must be filed with the MERN (Ministère de l'Énergie et des Ressources naturelles) with appropriate proof of exploration expenses. Grupo Moje Ltd. is responsible for the submission of the assessment work for Gold Bullion and will be filing the assessment work.

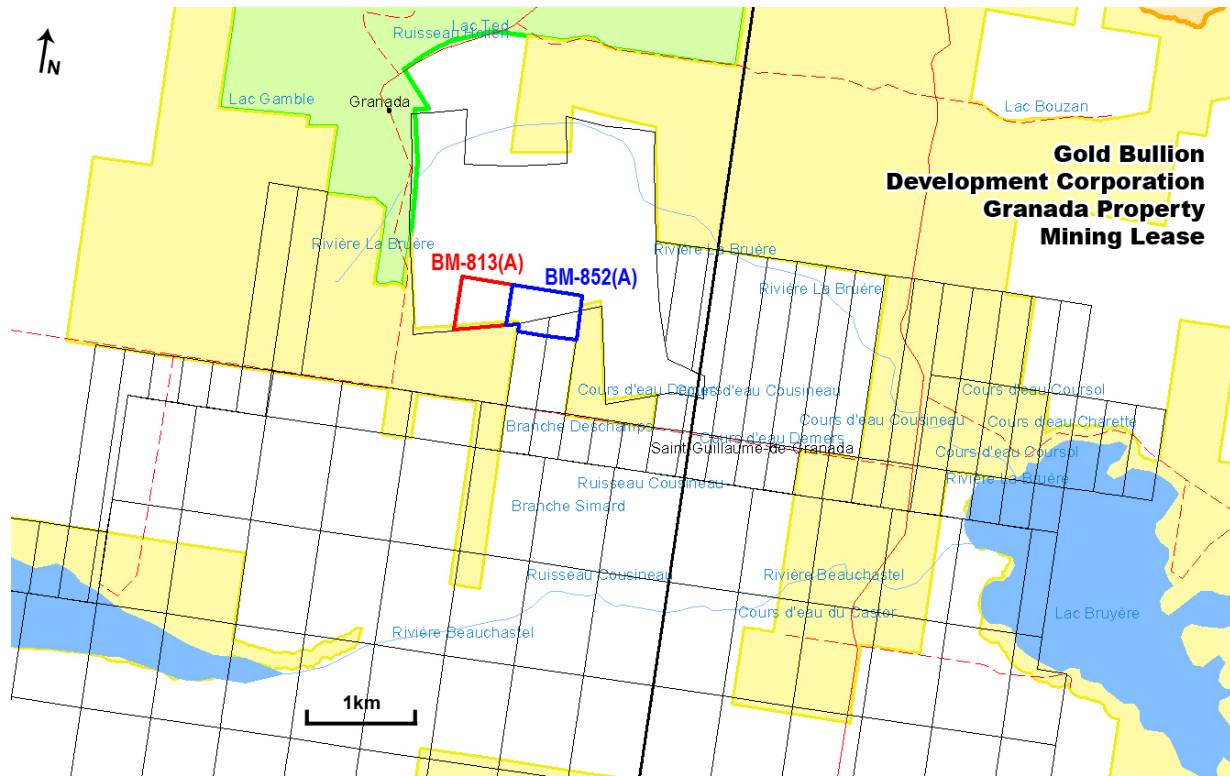

Figure 4-3: Location of the mining lease for which Mousseau Tremblay Inc. has 3% NSR.

Surface rights on the Property are held by the Québec Government. A summary of the mineral claims holdings is presented in the Table 4-1.

Table 4-1: Summary of Granada claims held by the company as of March 26th, 2014 verification.

NTS Map Sheet	Title	Claim №	Status	Issue Date	Expiry Date	Hectares	Title Holder	Renewal Treatment
SNRC 32D03	BM	813	Active	20/09/1993	19/09/2023	21.12	Gold Bullion Development Corporation inc. (85819) 100 % (responsible)	No
SNRC 32D03	BM	852	Active	28/02/2000	29/03/2020	22.47	Gold Bullion Development Corporation inc. (85819) 100 % (responsible)	No
SNRC 32D03	CDC	2174143	Active	06/11/2008	05/11/2014	57.45	Gold Bullion Development Corporation inc. (85819) 100 % (responsible)	No
SNRC 32D03	CDC	2174144	Active	06/11/2008	05/11/2014	57.45	Gold Bullion Development Corporation inc. (85819) 100 % (responsible)	No
SNRC 32D03	CDC	2174145	Active	06/11/2008	05/11/2014	57.45	Gold Bullion Development Corporation inc. (85819) 100 % (responsible)	No
SNRC 32D03	CDC	2174146	Active	06/11/2008	05/11/2016	57.45	Gold Bullion Development Corporation inc. (85819) 100 % (responsible)	No
SNRC 32D03	CDC	2174147	Active	06/11/2008	05/11/2016	57.45	Gold Bullion Development Corporation inc. (85819) 100 % (responsible)	No
SNRC 32D03	CDC	2174148	Active	06/11/2008	05/11/2016	57.45	Gold Bullion Development Corporation inc. (85819) 100 % (responsible)	No
SNRC 32D03	CDC	2174149	Active	06/11/2008	05/11/2016	57.44	Gold Bullion Development Corporation inc. (85819) 100 % (responsible)	No
SNRC 32D03	CDC	2174150	Active	06/11/2008	05/11/2016	57.44	Gold Bullion Development Corporation inc. (85819) 100 % (responsible)	No
SNRC 32D03	CDC	2174151	Active	06/11/2008	05/11/2016	57.44	Gold Bullion Development Corporation inc. (85819) 100 % (responsible)	No
SNRC 32D03	CDC	2174152	Active	06/11/2008	05/11/2016	57.44	Gold Bullion Development Corporation inc. (85819) 100 % (responsible)	No
SNRC 32D03	CDC	2174153	Active	06/11/2008	05/11/2016	57.44	Gold Bullion Development Corporation inc. (85819) 100 % (responsible)	No
SNRC 32D03	CDC	2174154	Active	06/11/2008	05/11/2016	57.44	Gold Bullion Development Corporation inc. (85819) 100 % (responsible)	No
SNRC 32D03	CDC	2190880	Active	06/10/2009	05/10/2017	57.44	Gold Bullion Development Corporation inc. (85819) 100 % (responsible)	No
SNRC 32D03	CDC	2192716	Active	26/10/2009	25/10/2017	57.44	Gold Bullion Development Corporation inc. (85819) 100 % (responsible)	No
SNRC 32D03	CDC	2192717	Active	26/10/2009	25/10/2017	57.44	Gold Bullion Development Corporation inc. (85819) 100 % (responsible)	No
SNRC 32D02	CDC	2197131	Active	09/12/2009	08/12/2015	42.56	Gold Bullion Development Corporation inc. (85819) 100 % (responsible)	No
SNRC 32D02	CDC	2197132	Active	09/12/2009	08/12/2015	42.57	Gold Bullion Development Corporation inc. (85819) 100 % (responsible)	No
SNRC 32D02	CDC	2197133	Active	09/12/2009	08/12/2015	42.56	Gold Bullion Development Corporation inc. (85819) 100 % (responsible)	No
SNRC 32D02	CDC	2197134	Active	09/12/2009	08/12/2015	42.55	Gold Bullion Development Corporation inc. (85819) 100 % (responsible)	No
SNRC 32D03	CDC	2201165	Active	18/01/2010	17/01/2018	42.80	Gold Bullion Development Corporation inc. (85819) 100 % (responsible)	No
SNRC 32D03	CDC	2201166	Active	18/01/2010	17/01/2018	42.78	Gold Bullion Development Corporation inc. (85819) 100 % (responsible)	No
SNRC 32D03	CDC	2203160	Active	26/01/2010	25/01/2016	8.22	Gold Bullion Development Corporation inc. (85819) 100 % (responsible)	No

NTS Map Sheet	Title	Claim №	Status	Issue Date	Expiry Date	Hectares	Title Holder	Renewal Treatment
SNRC 32D02	CDC	2206417	Active	22/02/2010	21/02/2016	57.44	Gold Bullion Development Corporation inc. (85819) 100 % (responsible)	No
SNRC 32D02	CDC	2206418	Active	22/02/2010	21/02/2016	57.44	Gold Bullion Development Corporation inc. (85819) 100 % (responsible)	No
SNRC 32D03	CDC	2206419	Active	22/02/2010	21/02/2016	57.43	Gold Bullion Development Corporation inc. (85819) 100 % (responsible)	No
SNRC 32D03	CDC	2206420	Active	22/02/2010	21/02/2016	57.43	Gold Bullion Development Corporation inc. (85819) 100 % (responsible)	No
SNRC 32D03	CDC	2206421	Active	22/02/2010	21/02/2016	24.94	Gold Bullion Development Corporation inc. (85819) 100 % (responsible)	No
SNRC 32D03	CDC	2206422	Active	22/02/2010	21/02/2016	42.27	Gold Bullion Development Corporation inc. (85819) 100 % (responsible)	No
SNRC 32D02	CDC	2206423	Active	22/02/2010	21/02/2016	10.62	Gold Bullion Development Corporation inc. (85819) 100 % (responsible)	No
SNRC 32D02	CDC	2206424	Active	22/02/2010	21/02/2016	10.62	Gold Bullion Development Corporation inc. (85819) 100 % (responsible)	No
SNRC 32D02	CDC	2206425	Active	22/02/2010	21/02/2016	10.64	Gold Bullion Development Corporation inc. (85819) 100 % (responsible)	No
SNRC 32D02	CDC	2206426	Active	22/02/2010	21/02/2016	10.64	Gold Bullion Development Corporation inc. (85819) 100 % (responsible)	No
SNRC 32D02	CDC	2206427	Active	22/02/2010	21/02/2016	10.64	Gold Bullion Development Corporation inc. (85819) 100 % (responsible)	No
SNRC 32D03	CDC	2206428	Active	22/02/2010	21/02/2016	20.29	Gold Bullion Development Corporation inc. (85819) 100 % (responsible)	No
SNRC 32D03	CDC	2206429	Active	22/02/2010	21/02/2016	10.47	Gold Bullion Development Corporation inc. (85819) 100 % (responsible)	No
SNRC 32D03	CDC	2206430	Active	22/02/2010	21/02/2016	10.48	Gold Bullion Development Corporation inc. (85819) 100 % (responsible)	No
SNRC 32D03	CDC	2206431	Active	22/02/2010	21/02/2016	10.49	Gold Bullion Development Corporation inc. (85819) 100 % (responsible)	No
SNRC 32D03	CDC	2206432	Active	22/02/2010	21/02/2016	10.50	Gold Bullion Development Corporation inc. (85819) 100 % (responsible)	No
SNRC 32D03	CDC	2206433	Active	22/02/2010	21/02/2016	8.76	Gold Bullion Development Corporation inc. (85819) 100 % (responsible)	No
SNRC 32D03	CDC	2206434	Active	22/02/2010	21/02/2016	10.57	Gold Bullion Development Corporation inc. (85819) 100 % (responsible)	No
SNRC 32D03	CDC	2206435	Active	22/02/2010	21/02/2016	10.57	Gold Bullion Development Corporation inc. (85819) 100 % (responsible)	No
SNRC 32D03	CDC	2206436	Active	22/02/2010	21/02/2016	10.57	Gold Bullion Development Corporation inc. (85819) 100 % (responsible)	No
SNRC 32D03	CDC	2206437	Active	22/02/2010	21/02/2016	10.59	Gold Bullion Development Corporation inc. (85819) 100 % (responsible)	No
SNRC 32D03	CDC	2206438	Active	22/02/2010	21/02/2016	10.60	Gold Bullion Development Corporation inc. (85819) 100 % (responsible)	No
SNRC 32D03	CDC	2206439	Active	22/02/2010	21/02/2016	10.59	Gold Bullion Development Corporation inc. (85819) 100 % (responsible)	No
SNRC 32D03	CDC	2206440	Active	22/02/2010	21/02/2016	16.55	Gold Bullion Development Corporation inc. (85819) 100 % (responsible)	No
SNRC 32D03	CDC	2206441	Active	22/02/2010	21/02/2016	8.13	Gold Bullion Development Corporation inc. (85819) 100 % (responsible)	No

NTS Map Sheet	Title	Claim №	Status	Issue Date	Expiry Date	Hectares	Title Holder	Renewal Treatment
SNRC 32D03	CDC	2206442	Active	22/02/2010	21/02/2016	16.67	Gold Bullion Development Corporation inc. (85819) 100 % (responsible)	No
SNRC 32D03	CDC	2206443	Active	22/02/2010	21/02/2016	5.10	Gold Bullion Development Corporation inc. (85819) 100 % (responsible)	No
SNRC 32D03	CDC	2206444	Active	22/02/2010	21/02/2016	16.60	Gold Bullion Development Corporation inc. (85819) 100 % (responsible)	No
SNRC 32D03	CDC	2206445	Active	22/02/2010	21/02/2016	16.54	Gold Bullion Development Corporation inc. (85819) 100 % (responsible)	No
SNRC 32D02	CDC	2206446	Active	22/02/2010	21/02/2016	57.48	Gold Bullion Development Corporation inc. (85819) 100 % (responsible)	No
SNRC 32D02	CDC	2206447	Active	22/02/2010	21/02/2016	57.48	Gold Bullion Development Corporation inc. (85819) 100 % (responsible)	No
SNRC 32D02	CDC	2206448	Active	22/02/2010	21/02/2016	57.48	Gold Bullion Development Corporation inc. (85819) 100 % (responsible)	No
SNRC 32D02	CDC	2206449	Active	22/02/2010	21/02/2016	57.47	Gold Bullion Development Corporation inc. (85819) 100 % (responsible)	No
SNRC 32D02	CDC	2206450	Active	22/02/2010	21/02/2016	57.47	Gold Bullion Development Corporation inc. (85819) 100 % (responsible)	No
SNRC 32D02	CDC	2206451	Active	22/02/2010	21/02/2016	57.47	Gold Bullion Development Corporation inc. (85819) 100 % (responsible)	No
SNRC 32D02	CDC	2206452	Active	22/02/2010	21/02/2016	57.47	Gold Bullion Development Corporation inc. (85819) 100 % (responsible)	No
SNRC 32D02	CDC	2206453	Active	22/02/2010	21/02/2016	57.47	Gold Bullion Development Corporation inc. (85819) 100 % (responsible)	No
SNRC 32D02	CDC	2206454	Active	22/02/2010	21/02/2016	57.46	Gold Bullion Development Corporation inc. (85819) 100 % (responsible)	No
SNRC 32D02	CDC	2206455	Active	22/02/2010	21/02/2016	57.46	Gold Bullion Development Corporation inc. (85819) 100 % (responsible)	No
SNRC 32D02	CDC	2206456	Active	22/02/2010	21/02/2016	57.45	Gold Bullion Development Corporation inc. (85819) 100 % (responsible)	No
SNRC 32D02	CDC	2206457	Active	22/02/2010	21/02/2016	57.45	Gold Bullion Development Corporation inc. (85819) 100 % (responsible)	No
SNRC 32D03	CDC	2206464	Active	22/02/2010	21/02/2016	0.57	Gold Bullion Development Corporation inc. (85819) 100 % (responsible)	No
SNRC 32D02	CDC	2224376	Active	30/04/2010	29/04/2016	57.46	Gold Bullion Development Corporation inc. (85819) 100 % (responsible)	No
SNRC 32D02	CDC	2224377	Active	30/04/2010	29/04/2016	57.45	Gold Bullion Development Corporation inc. (85819) 100 % (responsible)	No
SNRC 32D02	CDC	2224378	Active	30/04/2010	29/04/2016	57.45	Gold Bullion Development Corporation inc. (85819) 100 % (responsible)	No
SNRC 32D02	CDC	2224384	Active	30/04/2010	29/04/2016	57.44	Gold Bullion Development Corporation inc. (85819) 100 % (responsible)	No
SNRC 32D02	CDC	2224385	Active	30/04/2010	29/04/2016	57.44	Gold Bullion Development Corporation inc. (85819) 100 % (responsible)	No
SNRC 32D02	CDC	2224386	Active	30/04/2010	29/04/2016	57.44	Gold Bullion Development Corporation inc. (85819) 100 % (responsible)	No
SNRC 32D02	CDC	2224387	Active	30/04/2010	29/04/2016	37.40	Gold Bullion Development Corporation inc. (85819) 100 % (responsible)	No
SNRC 32D02	CDC	2224388	Active	30/04/2010	29/04/2016	57.43	Gold Bullion Development Corporation inc. (85819) 100 % (responsible)	No

NTS Map Sheet	Title	Claim №	Status	Issue Date	Expiry Date	Hectares	Title Holder	Renewal Treatment
SNRC 32D02	CDC	2224389	Active	30/04/2010	29/04/2016	57.43	Gold Bullion Development Corporation inc. (85819) 100 % (responsible)	No
SNRC 32D02	CDC	2224390	Active	30/04/2010	29/04/2016	57.43	Gold Bullion Development Corporation inc. (85819) 100 % (responsible)	No
SNRC 32D02	CDC	2224391	Active	30/04/2010	29/04/2016	57.43	Gold Bullion Development Corporation inc. (85819) 100 % (responsible)	No
SNRC 32D02	CDC	2224392	Active	30/04/2010	29/04/2016	57.43	Gold Bullion Development Corporation inc. (85819) 100 % (responsible)	No
SNRC 32D02	CDC	2224393	Active	30/04/2010	29/04/2016	20.88	Gold Bullion Development Corporation inc. (85819) 100 % (responsible)	No
SNRC 32D02	CDC	2224394	Active	30/04/2010	29/04/2016	10.60	Gold Bullion Development Corporation inc. (85819) 100 % (responsible)	No
SNRC 32D02	CDC	2224395	Active	30/04/2010	29/04/2016	10.61	Gold Bullion Development Corporation inc. (85819) 100 % (responsible)	No
SNRC 32D02	CDC	2224396	Active	30/04/2010	29/04/2016	10.61	Gold Bullion Development Corporation inc. (85819) 100 % (responsible)	No
SNRC 32D02	CDC	2224397	Active	30/04/2010	29/04/2016	10.61	Gold Bullion Development Corporation inc. (85819) 100 % (responsible)	No
SNRC 32D02	CDC	2224398	Active	30/04/2010	29/04/2016	10.64	Gold Bullion Development Corporation inc. (85819) 100 % (responsible)	No
SNRC 32D02	CDC	2224399	Active	30/04/2010	29/04/2016	10.63	Gold Bullion Development Corporation inc. (85819) 100 % (responsible)	No
SNRC 32D03	CDC	2224413	Active	30/04/2010	29/04/2016	57.44	Gold Bullion Development Corporation inc. (85819) 100 % (responsible)	No
SNRC 32D03	CDC	2224414	Active	30/04/2010	29/04/2016	57.44	Gold Bullion Development Corporation inc. (85819) 100 % (responsible)	No
SNRC 32D03	CDC	2224415	Active	30/04/2010	29/04/2016	57.44	Gold Bullion Development Corporation inc. (85819) 100 % (responsible)	No
SNRC 32D03	CDC	2224416	Active	30/04/2010	29/04/2016	57.44	Gold Bullion Development Corporation inc. (85819) 100 % (responsible)	No
SNRC 32D03	CDC	2224417	Active	30/04/2010	29/04/2016	19.52	Gold Bullion Development Corporation inc. (85819) 100 % (responsible)	No
SNRC 32D03	CDC	2224418	Active	30/04/2010	29/04/2016	57.44	Gold Bullion Development Corporation inc. (85819) 100 % (responsible)	No
SNRC 32D03	CDC	2224419	Active	30/04/2010	29/04/2016	57.44	Gold Bullion Development Corporation inc. (85819) 100 % (responsible)	No
SNRC 32D03	CDC	2224420	Active	30/04/2010	29/04/2016	57.43	Gold Bullion Development Corporation inc. (85819) 100 % (responsible)	No
SNRC 32D03	CDC	2224421	Active	30/04/2010	29/04/2016	57.43	Gold Bullion Development Corporation inc. (85819) 100 % (responsible)	No
SNRC 32D03	CDC	2224422	Active	30/04/2010	29/04/2016	57.43	Gold Bullion Development Corporation inc. (85819) 100 % (responsible)	No
SNRC 32D03	CDC	2224423	Active	30/04/2010	29/04/2016	57.43	Gold Bullion Development Corporation inc. (85819) 100 % (responsible)	No
SNRC 32D03	CDC	2224424	Active	30/04/2010	29/04/2016	57.43	Gold Bullion Development Corporation inc. (85819) 100 % (responsible)	No
SNRC 32D03	CDC	2224425	Active	30/04/2010	29/04/2016	57.43	Gold Bullion Development Corporation inc. (85819) 100 % (responsible)	No
SNRC 32D03	CDC	2224426	Active	30/04/2010	29/04/2016	24.98	Gold Bullion Development Corporation inc. (85819) 100 % (responsible)	No

NTS Map Sheet	Title	Claim №	Status	Issue Date	Expiry Date	Hectares	Title Holder	Renewal Treatment
SNRC 32D03	CDC	2224427	Active	30/04/2010	29/04/2016	25.03	Gold Bullion Development Corporation inc. (85819) 100 % (responsible)	No
SNRC 32D02,32D03	CDC	2224428	Active	30/04/2010	29/04/2016	10.60	Gold Bullion Development Corporation inc. (85819) 100 % (responsible)	No
SNRC 32D03	CDC	2240709	Active	14/07/2010	13/07/2016	33.55	Gold Bullion Development Corporation inc. (85819) 100 % (responsible)	No
SNRC 32D02	CDC	2249792	Active	14/09/2010	13/09/2014	10.63	Gold Bullion Development Corporation inc. (85819) 100 % (responsible)	No
SNRC 32D02	CDC	2251568	Active	28/09/2010	27/09/2014	28.53	Gold Bullion Development Corporation inc. (85819) 100 % (responsible)	No
SNRC 32D02	CDC	2251569	Active	28/09/2010	27/09/2014	57.42	Gold Bullion Development Corporation inc. (85819) 100 % (responsible)	No
SNRC 32D02	CDC	2251570	Active	28/09/2010	27/09/2014	28.26	Gold Bullion Development Corporation inc. (85819) 100 % (responsible)	No
SNRC 32D02	CDC	2251571	Active	28/09/2010	27/09/2014	57.41	Gold Bullion Development Corporation inc. (85819) 100 % (responsible)	No
SNRC 32D02	CDC	2251572	Active	28/09/2010	27/09/2014	57.41	Gold Bullion Development Corporation inc. (85819) 100 % (responsible)	No
SNRC 32D02	CDC	2251577	Active	28/09/2010	27/09/2014	5.42	Gold Bullion Development Corporation inc. (85819) 100 % (responsible)	No
SNRC 32D02	CDC	2251598	Active	28/09/2010	27/09/2014	9.97	Gold Bullion Development Corporation inc. (85819) 100 % (responsible)	No
SNRC 32D02	CDC	2251625	Active	28/09/2010	27/09/2014	10.02	Gold Bullion Development Corporation inc. (85819) 100 % (responsible)	No
SNRC 32D02	CDC	2251643	Active	28/09/2010	27/09/2014	0.63	Gold Bullion Development Corporation inc. (85819) 100 % (responsible)	No
SNRC 32D02	CDC	2251653	Active	28/09/2010	27/09/2014	42.67	Gold Bullion Development Corporation inc. (85819) 100 % (responsible)	No
SNRC 32D02	CDC	2251654	Active	28/09/2010	27/09/2014	42.59	Gold Bullion Development Corporation inc. (85819) 100 % (responsible)	No
SNRC 32D02	CDC	2251655	Active	28/09/2010	27/09/2014	42.65	Gold Bullion Development Corporation inc. (85819) 100 % (responsible)	No
SNRC 32D02	CDC	2251656	Active	28/09/2010	27/09/2014	42.61	Gold Bullion Development Corporation inc. (85819) 100 % (responsible)	No
SNRC 32D02	CDC	2251657	Active	28/09/2010	27/09/2014	42.59	Gold Bullion Development Corporation inc. (85819) 100 % (responsible)	No
SNRC 32D02	CDC	2251658	Active	28/09/2010	27/09/2014	42.60	Gold Bullion Development Corporation inc. (85819) 100 % (responsible)	No
SNRC 32D02	CDC	2251659	Active	28/09/2010	27/09/2014	42.59	Gold Bullion Development Corporation inc. (85819) 100 % (responsible)	No
SNRC 32D02	CDC	2251660	Active	28/09/2010	27/09/2014	42.59	Gold Bullion Development Corporation inc. (85819) 100 % (responsible)	No
SNRC 32D02	CDC	2251661	Active	28/09/2010	27/09/2014	42.57	Gold Bullion Development Corporation inc. (85819) 100 % (responsible)	No
SNRC 32D02	CDC	2251662	Active	28/09/2010	27/09/2014	42.60	Gold Bullion Development Corporation inc. (85819) 100 % (responsible)	No
SNRC 32D02	CDC	2251663	Active	28/09/2010	27/09/2014	42.57	Gold Bullion Development Corporation inc. (85819) 100 % (responsible)	No
SNRC 32D02	CDC	2251664	Active	28/09/2010	27/09/2014	42.56	Gold Bullion Development Corporation inc. (85819) 100 % (responsible)	No

NTS Map Sheet	Title	Claim №	Status	Issue Date	Expiry Date	Hectares	Title Holder	Renewal Treatment
SNRC 32D02	CDC	2251665	Active	28/09/2010	27/09/2014	42.57	Gold Bullion Development Corporation inc. (85819) 100 % (responsible)	No
SNRC 32D02	CDC	2251666	Active	28/09/2010	27/09/2014	42.55	Gold Bullion Development Corporation inc. (85819) 100 % (responsible)	No
SNRC 32D02	CDC	2251667	Active	28/09/2010	27/09/2014	42.55	Gold Bullion Development Corporation inc. (85819) 100 % (responsible)	No
SNRC 32D02	CDC	2251668	Active	28/09/2010	27/09/2014	42.55	Gold Bullion Development Corporation inc. (85819) 100 % (responsible)	No
SNRC 32D02	CDC	2251669	Active	28/09/2010	27/09/2014	42.55	Gold Bullion Development Corporation inc. (85819) 100 % (responsible)	No
SNRC 32D02	CDC	2251680	Active	28/09/2010	27/09/2014	42.55	Gold Bullion Development Corporation inc. (85819) 100 % (responsible)	No
SNRC 32D02	CDC	2251681	Active	28/09/2010	27/09/2014	42.56	Gold Bullion Development Corporation inc. (85819) 100 % (responsible)	No
SNRC 32D02	CDC	2251682	Active	28/09/2010	27/09/2014	42.55	Gold Bullion Development Corporation inc. (85819) 100 % (responsible)	No
SNRC 32D02	CDC	2251683	Active	28/09/2010	27/09/2014	42.56	Gold Bullion Development Corporation inc. (85819) 100 % (responsible)	No
SNRC 32D02	CDC	2251684	Active	28/09/2010	27/09/2014	42.54	Gold Bullion Development Corporation inc. (85819) 100 % (responsible)	No
SNRC 32D02	CDC	2251685	Active	28/09/2010	27/09/2014	42.54	Gold Bullion Development Corporation inc. (85819) 100 % (responsible)	No
SNRC 32D02	CDC	2251686	Active	28/09/2010	27/09/2014	42.53	Gold Bullion Development Corporation inc. (85819) 100 % (responsible)	No
SNRC 32D02	CDC	2251687	Active	28/09/2010	27/09/2014	42.53	Gold Bullion Development Corporation inc. (85819) 100 % (responsible)	No
SNRC 32D02	CDC	2251688	Active	28/09/2010	27/09/2014	42.54	Gold Bullion Development Corporation inc. (85819) 100 % (responsible)	No
SNRC 32D02	CDC	2251689	Active	28/09/2010	27/09/2014	42.53	Gold Bullion Development Corporation inc. (85819) 100 % (responsible)	No
SNRC 32D02	CDC	2251690	Active	28/09/2010	27/09/2014	42.53	Gold Bullion Development Corporation inc. (85819) 100 % (responsible)	No
SNRC 32D02	CDC	2251691	Active	28/09/2010	27/09/2014	42.53	Gold Bullion Development Corporation inc. (85819) 100 % (responsible)	No
SNRC 32D03	CDC	2251926	Active	29/09/2010	28/09/2014	57.45	Gold Bullion Development Corporation inc. (85819) 100 % (responsible)	No
SNRC 32D03	CDC	2251927	Active	29/09/2010	28/09/2014	57.45	Gold Bullion Development Corporation inc. (85819) 100 % (responsible)	No
SNRC 32D03	CDC	2251928	Active	29/09/2010	28/09/2014	57.45	Gold Bullion Development Corporation inc. (85819) 100 % (responsible)	No
SNRC 32D03	CDC	2251929	Active	29/09/2010	28/09/2014	57.45	Gold Bullion Development Corporation inc. (85819) 100 % (responsible)	No
SNRC 32D03	CDC	2251930	Active	29/09/2010	28/09/2014	57.45	Gold Bullion Development Corporation inc. (85819) 100 % (responsible)	No
SNRC 32D03	CDC	2251931	Active	29/09/2010	28/09/2014	57.44	Gold Bullion Development Corporation inc. (85819) 100 % (responsible)	No
SNRC 32D03	CDC	2251932	Active	29/09/2010	28/09/2014	57.44	Gold Bullion Development Corporation inc. (85819) 100 % (responsible)	No
SNRC 32D03	CDC	2251933	Active	29/09/2010	28/09/2014	57.44	Gold Bullion Development Corporation inc. (85819) 100 % (responsible)	No

NTS Map Sheet	Title	Claim №	Status	Issue Date	Expiry Date	Hectares	Title Holder	Renewal Treatment
SNRC 32D03	CDC	2251934	Active	29/09/2010	28/09/2014	57.44	Gold Bullion Development Corporation inc. (85819) 100 % (responsible)	No
SNRC 32D03	CDC	2251935	Active	29/09/2010	28/09/2014	57.44	Gold Bullion Development Corporation inc. (85819) 100 % (responsible)	No
SNRC 32D03	CDC	2251936	Active	29/09/2010	28/09/2014	57.44	Gold Bullion Development Corporation inc. (85819) 100 % (responsible)	No
SNRC 32D03	CDC	2251937	Active	29/09/2010	28/09/2014	57.44	Gold Bullion Development Corporation inc. (85819) 100 % (responsible)	No
SNRC 32D03	CDC	2251938	Active	29/09/2010	28/09/2014	57.44	Gold Bullion Development Corporation inc. (85819) 100 % (responsible)	No
SNRC 32D03	CDC	2251939	Active	29/09/2010	28/09/2014	40.32	Gold Bullion Development Corporation inc. (85819) 100 % (responsible)	No
SNRC 32D03	CDC	2251940	Active	29/09/2010	28/09/2014	40.29	Gold Bullion Development Corporation inc. (85819) 100 % (responsible)	No
SNRC 32D03	CDC	2251941	Active	29/09/2010	28/09/2014	40.26	Gold Bullion Development Corporation inc. (85819) 100 % (responsible)	No
SNRC 32D03	CDC	2251942	Active	29/09/2010	28/09/2014	40.29	Gold Bullion Development Corporation inc. (85819) 100 % (responsible)	No
SNRC 32D03	CDC	2251943	Active	29/09/2010	28/09/2014	40.36	Gold Bullion Development Corporation inc. (85819) 100 % (responsible)	No
SNRC 32D03	CDC	2251944	Active	29/09/2010	28/09/2014	40.42	Gold Bullion Development Corporation inc. (85819) 100 % (responsible)	No
SNRC 32D02	CDC	2252324	Active	01/10/2010	30/09/2014	42.29	Gold Bullion Development Corporation inc. (85819) 100 % (responsible)	No
SNRC 32D03	CDC	2254672	Active	19/10/2010	18/10/2014	32.97	Gold Bullion Development Corporation inc. (85819) 100 % (responsible)	No
SNRC 32D03	CDC	2254673	Active	19/10/2010	18/10/2014	40.39	Gold Bullion Development Corporation inc. (85819) 100 % (responsible)	No
SNRC 32D03	CDC	2254674	Active	19/10/2010	18/10/2014	40.38	Gold Bullion Development Corporation inc. (85819) 100 % (responsible)	No
SNRC 32D03	CDC	2254675	Active	19/10/2010	18/10/2014	40.38	Gold Bullion Development Corporation inc. (85819) 100 % (responsible)	No
SNRC 32D03	CDC	2254676	Active	19/10/2010	18/10/2014	40.37	Gold Bullion Development Corporation inc. (85819) 100 % (responsible)	No
SNRC 32D03	CDC	2254677	Active	19/10/2010	18/10/2014	40.36	Gold Bullion Development Corporation inc. (85819) 100 % (responsible)	No
SNRC 32D03	CDC	2254678	Active	19/10/2010	18/10/2014	40.34	Gold Bullion Development Corporation inc. (85819) 100 % (responsible)	No
SNRC 32D03	CDC	2254679	Active	19/10/2010	18/10/2014	33.28	Gold Bullion Development Corporation inc. (85819) 100 % (responsible)	No
SNRC 32D02	CDC	2258227	Active	01/11/2010	31/10/2014	5.61	Gold Bullion Development Corporation inc. (85819) 100 % (responsible)	No
SNRC 32D02	CDC	2258228	Active	01/11/2010	31/10/2014	5.60	Gold Bullion Development Corporation inc. (85819) 100 % (responsible)	No
SNRC 32D02	CDC	2258229	Active	01/11/2010	31/10/2014	57.42	Gold Bullion Development Corporation inc. (85819) 100 % (responsible)	No
SNRC 32D02	CDC	2258230	Active	01/11/2010	31/10/2014	3.73	Gold Bullion Development Corporation inc. (85819) 100 % (responsible)	No
SNRC 32D02	CDC	2260573	Active	15/11/2010	14/11/2014	57.47	Gold Bullion Development Corporation inc. (85819) 100 % (responsible)	No

NTS Map Sheet	Title	Claim №	Status	Issue Date	Expiry Date	Hectares	Title Holder	Renewal Treatment
SNRC 32D02	CDC	2260755	Active	17/11/2010	16/11/2016	57.47	Gold Bullion Development Corporation inc. (85819) 100 % (responsible)	No
SNRC 32D02	CDC	2260756	Active	17/11/2010	16/11/2016	57.47	Gold Bullion Development Corporation inc. (85819) 100 % (responsible)	No
SNRC 32D02	CDC	2260757	Active	17/11/2010	16/11/2014	57.47	Gold Bullion Development Corporation inc. (85819) 100 % (responsible)	Yes
SNRC 32D02	CDC	2260758	Active	17/11/2010	16/11/2016	57.47	Gold Bullion Development Corporation inc. (85819) 100 % (responsible)	No
SNRC 32D02	CDC	2260759	Active	17/11/2010	16/11/2014	57.47	Gold Bullion Development Corporation inc. (85819) 100 % (responsible)	No
SNRC 32D02	CDC	2260760	Active	17/11/2010	16/11/2016	57.46	Gold Bullion Development Corporation inc. (85819) 100 % (responsible)	No
SNRC 32D02	CDC	2260761	Active	17/11/2010	16/11/2016	57.46	Gold Bullion Development Corporation inc. (85819) 100 % (responsible)	No
SNRC 32D02	CDC	2260762	Active	17/11/2010	16/11/2016	57.46	Gold Bullion Development Corporation inc. (85819) 100 % (responsible)	No
SNRC 32D02	CDC	2260763	Active	17/11/2010	16/11/2016	57.46	Gold Bullion Development Corporation inc. (85819) 100 % (responsible)	No
SNRC 32D02	CDC	2260764	Active	17/11/2010	16/11/2014	57.46	Gold Bullion Development Corporation inc. (85819) 100 % (responsible)	No
SNRC 32D02	CDC	2260765	Active	17/11/2010	16/11/2014	57.46	Gold Bullion Development Corporation inc. (85819) 100 % (responsible)	No
SNRC 32D02	CDC	2260766	Active	17/11/2010	16/11/2016	5.40	Gold Bullion Development Corporation inc. (85819) 100 % (responsible)	No
SNRC 32D02	CDC	2260767	Active	17/11/2010	16/11/2016	5.48	Gold Bullion Development Corporation inc. (85819) 100 % (responsible)	No
SNRC 32D02	CDC	2260768	Active	17/11/2010	16/11/2016	5.59	Gold Bullion Development Corporation inc. (85819) 100 % (responsible)	No
SNRC 32D02	CDC	2260769	Active	17/11/2010	16/11/2016	5.61	Gold Bullion Development Corporation inc. (85819) 100 % (responsible)	No
SNRC 32D02	CDC	2265413	Active	17/12/2010	16/12/2014	57.46	Gold Bullion Development Corporation inc. (85819) 100 % (responsible)	No
SNRC 32D02	CDC	2265414	Active	17/12/2010	16/12/2014	57.46	Gold Bullion Development Corporation inc. (85819) 100 % (responsible)	No
SNRC 32D02	CDC	2265415	Active	17/12/2010	16/12/2014	32.46	Gold Bullion Development Corporation inc. (85819) 100 % (responsible)	No
SNRC 32D02	CDC	2265416	Active	17/12/2010	16/12/2014	57.45	Gold Bullion Development Corporation inc. (85819) 100 % (responsible)	No
SNRC 32D02	CDC	2265417	Active	17/12/2010	16/12/2014	57.45	Gold Bullion Development Corporation inc. (85819) 100 % (responsible)	No
SNRC 32D02	CDC	2265418	Active	17/12/2010	16/12/2014	57.45	Gold Bullion Development Corporation inc. (85819) 100 % (responsible)	No
SNRC 32D02	CDC	2265419	Active	17/12/2010	16/12/2014	57.45	Gold Bullion Development Corporation inc. (85819) 100 % (responsible)	No
SNRC 32D02	CDC	2265420	Active	17/12/2010	16/12/2014	29.40	Gold Bullion Development Corporation inc. (85819) 100 % (responsible)	No
SNRC 32D02	CDC	2265421	Active	17/12/2010	16/12/2014	57.44	Gold Bullion Development Corporation inc. (85819) 100 % (responsible)	No
SNRC 32D02	CDC	2265422	Active	17/12/2010	16/12/2014	57.44	Gold Bullion Development Corporation inc. (85819) 100 % (responsible)	No

NTS Map Sheet	Title	Claim №	Status	Issue Date	Expiry Date	Hectares	Title Holder	Renewal Treatment
SNRC 32D02	CDC	2265423	Active	17/12/2010	16/12/2014	57.44	Gold Bullion Development Corporation inc. (85819) 100 % (responsible)	No
SNRC 32D02	CDC	2265424	Active	17/12/2010	16/12/2014	57.44	Gold Bullion Development Corporation inc. (85819) 100 % (responsible)	No
SNRC 32D02	CDC	2265425	Active	17/12/2010	16/12/2014	28.85	Gold Bullion Development Corporation inc. (85819) 100 % (responsible)	No
SNRC 32D02	CDC	2265426	Active	17/12/2010	16/12/2014	57.43	Gold Bullion Development Corporation inc. (85819) 100 % (responsible)	No
SNRC 32D02	CDC	2265427	Active	17/12/2010	16/12/2014	57.43	Gold Bullion Development Corporation inc. (85819) 100 % (responsible)	No
SNRC 32D02	CDC	2265428	Active	17/12/2010	16/12/2014	57.43	Gold Bullion Development Corporation inc. (85819) 100 % (responsible)	No
SNRC 32D02	CDC	2265429	Active	17/12/2010	16/12/2014	57.43	Gold Bullion Development Corporation inc. (85819) 100 % (responsible)	No
SNRC 32D02	CDC	2265430	Active	17/12/2010	16/12/2014	24.07	Gold Bullion Development Corporation inc. (85819) 100 % (responsible)	No
SNRC 32D02	CDC	2265431	Active	17/12/2010	16/12/2014	24.31	Gold Bullion Development Corporation inc. (85819) 100 % (responsible)	No
SNRC 32D02	CDC	2265432	Active	17/12/2010	16/12/2014	24.37	Gold Bullion Development Corporation inc. (85819) 100 % (responsible)	No
SNRC 32D02	CDC	2274418	Active	21/02/2011	20/02/2015	1.46	Gold Bullion Development Corporation inc. (85819) 100 % (responsible)	No
SNRC 32D02	CDC	2274658	Active	21/02/2011	20/02/2015	57.43	Gold Bullion Development Corporation inc. (85819) 100 % (responsible)	No
SNRC 32D02	CDC	2274659	Active	21/02/2011	20/02/2015	57.44	Gold Bullion Development Corporation inc. (85819) 100 % (responsible)	No
SNRC 32D02	CDC	2274660	Active	21/02/2011	20/02/2015	57.44	Gold Bullion Development Corporation inc. (85819) 100 % (responsible)	No
SNRC 32D02	CDC	2274661	Active	21/02/2011	20/02/2015	57.44	Gold Bullion Development Corporation inc. (85819) 100 % (responsible)	No
SNRC 32D02	CDC	2274662	Active	21/02/2011	20/02/2015	57.43	Gold Bullion Development Corporation inc. (85819) 100 % (responsible)	No
SNRC 32D02	CDC	2274663	Active	21/02/2011	20/02/2015	55.97	Gold Bullion Development Corporation inc. (85819) 100 % (responsible)	No
SNRC 32D02	CDC	2274664	Active	21/02/2011	20/02/2015	57.43	Gold Bullion Development Corporation inc. (85819) 100 % (responsible)	No
SNRC 32D02	CDC	2274665	Active	21/02/2011	20/02/2015	26.15	Gold Bullion Development Corporation inc. (85819) 100 % (responsible)	No
SNRC 32D02	CDC	2274666	Active	21/02/2011	20/02/2015	24.15	Gold Bullion Development Corporation inc. (85819) 100 % (responsible)	No
SNRC 32D02	CDC	2274667	Active	21/02/2011	20/02/2015	24.22	Gold Bullion Development Corporation inc. (85819) 100 % (responsible)	No
SNRC 32D03	CLD	P780010	Active	13/10/1972	24/03/2015	350.00	Gold Bullion Development Corporation inc. (85819) 100 % (responsible)	No
SNRC 32D02	CL	3845631	Active	07/11/1979	20/10/2015	40.00	Gold Bullion Development Corporation inc. (85819) 100 % (responsible)	No
SNRC 32D02	CL	3845632	Active	07/11/1979	20/10/2015	40.00	Gold Bullion Development Corporation inc. (85819) 100 % (responsible)	No
SNRC 32D02	CL	3845641	Active	07/11/1979	19/10/2015	40.00	Gold Bullion Development Corporation inc. (85819) 100 % (responsible)	No

NTS Map Sheet	Title	Claim №	Status	Issue Date	Expiry Date	Hectares	Title Holder	Renewal Treatment
SNRC 32D02	CL	3845642	Active	07/11/1979	19/10/2015	40.00	Gold Bullion Development Corporation inc. (85819) 100 % (responsible)	No
SNRC 32D02	CL	3845651	Active	07/11/1979	20/10/2015	20.00	Gold Bullion Development Corporation inc. (85819) 100 % (responsible)	No
SNRC 32D02	CL	3845652	Active	07/11/1979	20/10/2015	20.00	Gold Bullion Development Corporation inc. (85819) 100 % (responsible)	No
SNRC 32D02	CL	3845653	Active	07/11/1979	20/10/2015	20.00	Gold Bullion Development Corporation inc. (85819) 100 % (responsible)	No
SNRC 32D02	CL	3845654	Active	07/11/1979	20/10/2015	20.00	Gold Bullion Development Corporation inc. (85819) 100 % (responsible)	No
SNRC 32D02,32D03	CL	3845841	Active	07/11/1979	19/10/2015	39.00	Gold Bullion Development Corporation inc. (85819) 100 % (responsible)	No
SNRC 32D02	CL	3845842	Active	07/11/1979	19/10/2015	40.00	Gold Bullion Development Corporation inc. (85819) 100 % (responsible)	No
SNRC 32D03	CL	3845851	Active	07/11/1979	19/10/2015	16.00	Gold Bullion Development Corporation inc. (85819) 100 % (responsible)	No
SNRC 32D03	CL	3845852	Active	07/11/1979	19/10/2015	28.00	Gold Bullion Development Corporation inc. (85819) 100 % (responsible)	No
SNRC 32D02	CL	3845853	Active	07/11/1979	19/10/2015	20.00	Gold Bullion Development Corporation inc. (85819) 100 % (responsible)	No
SNRC 32D03	CL	3878491	Active	11/02/1980	20/01/2016	20.00	Gold Bullion Development Corporation inc. (85819) 100 % (responsible)	No
SNRC 32D03	CL	3878492	Active	11/02/1980	20/01/2016	20.00	Gold Bullion Development Corporation inc. (85819) 100 % (responsible)	No
SNRC 32D02	CL	3952881	Active	03/11/1980	15/10/2015	20.00	Gold Bullion Development Corporation inc. (85819) 100 % (responsible)	No
SNRC 32D02	CL	3952882	Active	03/11/1980	15/10/2015	20.00	Gold Bullion Development Corporation inc. (85819) 100 % (responsible)	No
SNRC 32D02	CL	3952883	Active	03/11/1980	15/10/2015	20.00	Gold Bullion Development Corporation inc. (85819) 100 % (responsible)	No
SNRC 32D02	CL	3952884	Active	03/11/1980	15/10/2015	20.00	Gold Bullion Development Corporation inc. (85819) 100 % (responsible)	No
SNRC 32D02	CL	3952891	Active	03/11/1980	15/10/2015	20.00	Gold Bullion Development Corporation inc. (85819) 100 % (responsible)	No
SNRC 32D02	CL	3952892	Active	03/11/1980	15/10/2015	20.00	Gold Bullion Development Corporation inc. (85819) 100 % (responsible)	No
SNRC 32D02	CL	3952893	Active	03/11/1980	15/10/2015	20.00	Gold Bullion Development Corporation inc. (85819) 100 % (responsible)	No
SNRC 32D02	CL	3952894	Active	03/11/1980	15/10/2015	20.00	Gold Bullion Development Corporation inc. (85819) 100 % (responsible)	No
SNRC 32D02	CL	5109754	Active	21/08/1993	20/08/2015	40.00	Gold Bullion Development Corporation inc. (85819) 100 % (responsible)	No
SNRC 32D02	CL	5109755	Active	21/08/1993	20/08/2015	40.00	Gold Bullion Development Corporation inc. (85819) 100 % (responsible)	No

Modified after GESTIM (Gestion des titres minier – Gouvernement du Québec) download: April 14th 2014

In writing of this report update, SGS Geostat is not aware of any additional royalties, back-in rights, payments or other agreements, encumbrances and environmental liabilities to which the Property could be subject.

Part of the Property is recovered by historical tailings and there are tailings in one of the old open pits, now filled with water. The old tailings belong to the "Ministère de l'Énergie et des Ressources naturelles, secteur Mines" (orphan site). Gold Bullion is taking actions to take care of them in direct communication with the MERN and MDDELCC. Test work has been undertaken at SGS Lakefield Laboratories indicating that it is viable to produce a marketable product.

Regarding the onsite waste pile, legacy of previous open-pit operations, Gold Bullion can use the rock for access road construction and it is also being used by local contractors for fill. An application for a Certificate of Authorization (C of A) is underway for the use of this material. Galarneau has just received its C of A to crush and screen aggregate. He has a contract 70,000 tonnes and to the author's knowledge has a C of A for this independent operation but the Company needs another C of A for the remaining fines which is being prepared by Goldminds Geoservices with SODAVEX.

Permits for exploration drilling to the north of the property are in good standing.

The property is outside Joannès wildlife preserve located to the east.

Figure 4-4 presents parts of the property which under urbanisation (green perimeter) exists and where outdoor activities (yellow perimeter) occur.

A potential risk exists with a proposed Bill n°14 (An Act respecting the development of mineral resources in keeping with the principles of sustainable development) that gives more power to Municipalities and MRC. Since these entities do not have qualified persons to review mineral projects it is one of the main concerns of the mineral industry. This situation applies to all mining and exploration projects in the Province of Québec and is not specific to the Granada property.

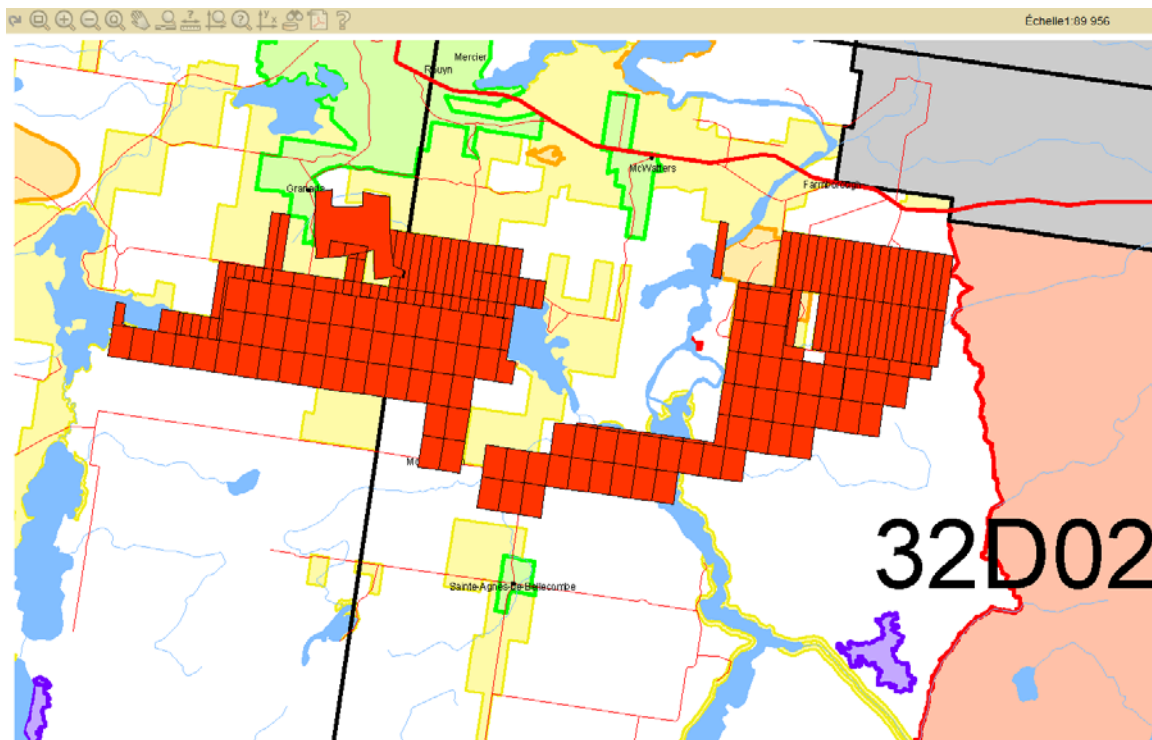

Figure 4-4: Property with urban (green) and outdoor activities (yellow) constraint parameters

5 Accessibility, Climate, Local Resources, Infrastructure and Physiography

Parts of this section were summarized from previous reports after validation for accuracy.

5.1 TOPOGRAPHY & PHYSIOGRAPHY

The topography is characterized by low-lying lightly forested areas separated by low ridges. The property is traversed by rare creeks which occupy swampy, shallow valleys. Relief is low, ranging from 274 m to 315 m above sea level, predominantly gentle sloping (Figure 5-1).

The property is located within the Abitibi clay belt, the remnant of the glacial Ojibway Lake. Clusters of isolated rock outcrops are found locally. In the main active exploration area, natural overburden is thin; typically ranging from 0 to 5 m in zones of interest.

5.2 ACCESS

Access to the property is provided by the Rouyn-Granada asphalt road, which is adjacent to the property and is 630 m west away from the existing gate. The connexion to the road is gained by a gravel roads and a regional snowmobile trail in winter.

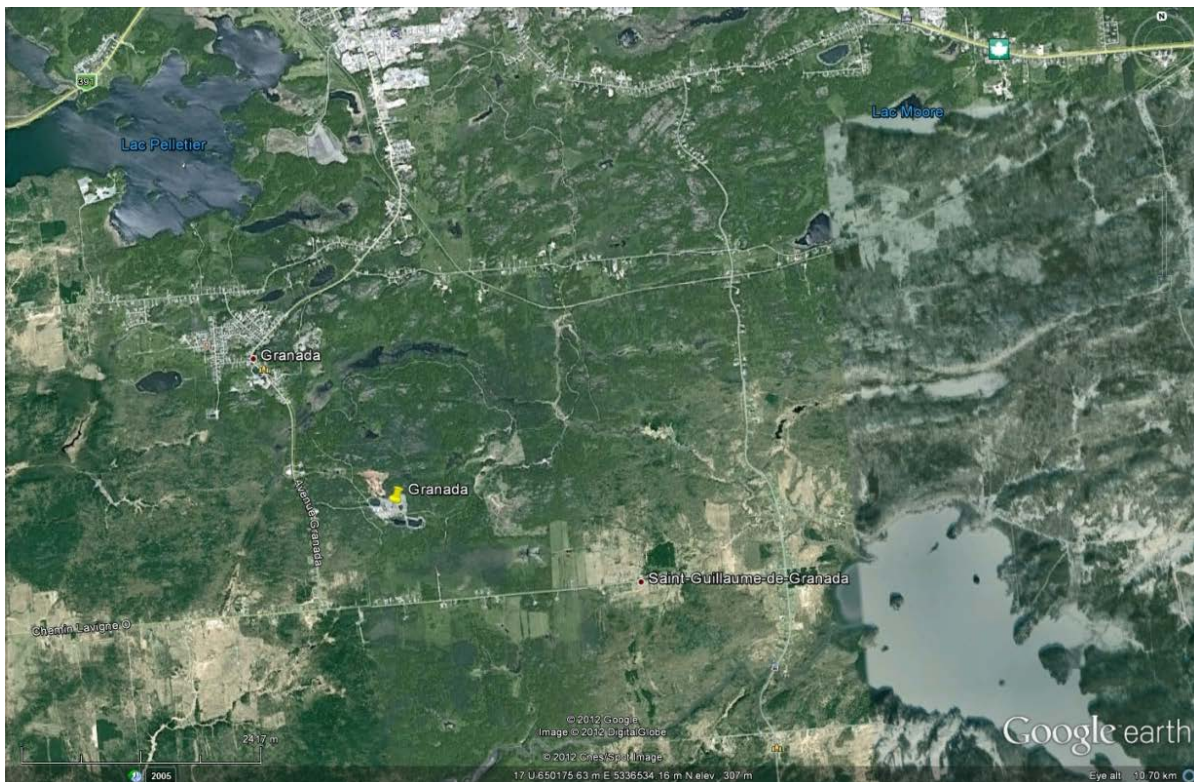

Figure 5-1: Satellite view from Google Earth

5.3 CLIMATE

The Granada property area and vicinity has a subarctic climate an intermediary between the temperate and polar climate (Dfb: Humid Continental Climate according to the Köppen climate classification). Summers are hot and winters are more severe than in most temperate climates. The vegetation is boreal and mixed in some places. The average temperature ranges between -18° C and -19° C in January to between 16° C and 17° C in July with cold and hot records such as -49.5° C in 1984 and 34.5° C in 1995. In winters it is more common to encounter temperatures around -10 and -20° C as summers become warmer, in general the temperatures are between 20 to 25° C, often with a Humidex index.

Average annual rainfall is approximately 976 mm and snowfall 258 cm. Winters are harsh and often lead to poor flying conditions. The practical field season is from May through October. Snowfall in November, December, January and February generally exceeds 55 cm per month and the wettest summer months are August and September with average rainfalls of 100 mm. Lake thaw usually in early April, and freeze-up in November. These are normal climatic conditions for the Abitibi region, where exploration work is usually conducted year round.

5.4 INFRASTRUCTURES

All the required services are provided on the property. Depending of the required volume, water supply is available from either Pelletier and/or Beauchastel Lake. Most services and manpower necessary for a mining operation are already offered in Rouyn-Noranda and vicinity. Rail transportation is also available. Rouyn-Noranda is also serviced by an airport located 13 km in straight line from the old pit.

A 25,000-volt transmission line parallels the above Rouyn-Granada road and can provide up to 12,000 kW to the property. An electrical sub-station in the range of 3,000 kW should be installed if additional power be required in the future. A natural gas pipeline services the borough of Granada and the headwaters to the La Bruere River originate along the western margin of the property. This being said, it is also known that additional electric power investment by Hydro Quebec for the region is required due to the booming of large scale high energy consuming projects and other high tonnage/low grade ventures at the development stage which may come to production in the coming years depending strongly of gold price and market conditions.

The area of the property is sufficient for an eventual mining operation with all required installations for mining personnel, potential tailings storage areas, potential waste disposal areas, heap leach pad areas, and potential processing plant site. An aerial view of the existing infrastructures (2010 photograph) is presented in the Figure 5-2. The RSW-Beroma's (UMCO) mobile gold mill used in 2000 has been recently dismantled and removed (2013-2014).

The existing office administrative building and conference room are made of mobile trailers. A core logging facility with garage and dry with washroom exist as a separate building.

The sanitary system has been damaged by diamond drilling under responsibility of previous consultant and will require some changes prior to operation.



Figure 5-2: Air view of infrastructures looking South-East (in 2010)

6 History

Parts of this section were summarized from previous reports, from D. Robinson, October 2006, after being validated for accuracy and previous SGS reports. All numbers related to resources and reserves in this historical section past 2012 are not NI 43-101 compliant and investors should not rely upon them.

The Granada Mine was one of the three first gold mining ventures in the Abitibi Belt of Northwestern Quebec along with O'Brien in Cadillac and Siscoe mine near Val D'Or.

1922-1923: WA and RC Gamble marked out the property. During these two years, exploration work was done, leading to the discovery of the vein #1.

1924-1925: McIntyre Porcupine Mines Limited dug several trenches and exploration wells to better define the veins, but dropped the option in 1925.

1927-1929: Granada Rouyn Mining Company Ltd resumed the option. The company drilled a first shaft on a dark vein #1; it reached a depth of 129 m. The vein was developed on five levels. In 1929, a mill with a capacity of 63 tonnes per day was built. Vein #2 is discovered.

1930-1935: Granada Gold Mines Ltd replaced Granada Rouyn Mining Company Ltd and deepened the first Shaft up to 200 m. Shaft #2 on the vein #2 was built in 1933. Latter was inclined and reached a vertical depth of 488 m. Lateral work stretched out 7,925 m and 11 levels. In 1934, the mill capacity was increased to 181 tonnes per day. From 1930 to 1935, Granada Gold Mines extracted 164,816 tonnes of ore at an average grade of 9.7 g/t Au and 1.5 g/t Ag. This ore came primarily from vein #2. Tailings of this ore were deposited in a tailing pond covering an area of approximately 50,000 m² and located just north of the old mill

1947-1950: Old Mill Gold Mines Limited carried out geophysical surveys. In 1950, shaft #1 was dewatered until 5th level, but no work was performed.

1967-1968: In 1967, the claims were submitted to the crown (failure to pay taxes) and were then acquired by several individuals who formed the company Stanford Mines Limited. In 1968, The Gamble acquired claims and conducted geophysical surveys and exploratory surveys.

1972-1980: Goldsearch acquired ownership and made some exploration work. New reserves of 294,835 tonnes 12g/t Au the vein #2 were then calculated.

1981-1991: In 1981, Kewagama Gold Mines (hereinafter by KWG Resources Inc.) and Goldsearch signed an agreement that allows Kewagama Gold Mines to acquire a 50% stake in the project Granada. In 1982, the mine was dewatered and underground and surface rehabilitation works were made. In 1983, Goldsearch obtained a certificate of approval for the development of the mine and reported to the vein #2 reserves 102,512 tonnes to 13.37 g/t Au and 3.43 g/t Ag. During the years 1989-1990, 27 surface drill-holes were performed as well as geophysical surveys throughout the property. In 1991, SEG Exploration Inc. acquired Goldsearch stakes.

1992: At the beginning of the taxation year 1992, KWG Resources drilled 69 holes totalling 2,973 m on the veins #1 and veins #2. During the same summer, KWG Resources and Exploration SEG performed stripping work of 4,078 m² in order to make a bulk sample.

1993: July 16, 1993, MRN issued to KWG Resources Inc. and SEG Resources Inc. Mining Lease 813 which covers most of the mineral resources of the Granada mine.

In July 1993, Granada Resources becomes 100% owner of the Granada property by buying Exploration SEG and KWG Resources stakes. In May 1994, the agreement was signed giving exploitation operation to KWG Resources.

Between 1992 and 1994, an overall assessment of the economic potential of Granada mine took place, along a resource estimate of the property undertaken by the firm A.C.A. Howe (1990, 1993a, 1993b and 1994).

1994: Granada Resources extracted a bulk sample of 87,311 tonnes grading 5.17 g/t Au pit #1. This generated 139,856 tonnes of waste have been piled on a sterile tailings located east of the pit #1.

1995: Met-Chem Pellemon produced an assessment of an operating vein #2 project through two open pits shallow (26 m). The amount of ore contained in these pits is estimated at 105,000 tonnes at an average grade of 3.45 g/t Au.

1996: Granada Resources extracted a bulk sample of 22,095 tonnes grading 3.46 g/t Au pit #2. This has also generated 4,309 tonnes of waste have increased the size of a sterile dumps to 1.2 hectares. In addition, 8,822 tons of ore were crushed and used in a trial separation using an optical sorting machine ("ore sorter," rented from a firm in Denver, Colorado). In principle, based on the color of crushed fragments, the unit separates fragments of quartz veins (high gold content) and fragments of rock (low gold content). The results of this trial have not been reported and the unit was returned to Denver. The crushed material resulting from this test was the sterile dumps located northwest of the pit #1.

1997: KWG Resources Inc. sold 100% of Granada Resources Inc. (a subsidiary company of KWG Resources Inc.) to Mousseau Tremblay Inc. (MTI).

1998: August 16, 1998, a commercial contract of sale and purchase of ore was made by Mousseau Tremblay Inc. Company RSW-Béroma. The latter wished to use the site Granada mine to demonstrate its concept Factory Modular Concentration ore Gold (UMCO).

1999: On 31 August 1999, RSW-Béroma and MTI applied to the Ministry of Environment Quebec for a certificate of authorization (C of A) in order to install a UMCO on Granada mine site and to conduct the following operations:

- extract 105,000 tonnes of ore pits #2 (55,000 tonnes) and #2A (50,000 tonnes);
- treat ore in the UMCO;
- carry out cyanides destruction (by SO₂/air method) in the final waste before its release in the pit #1.

On 21 September 1999, the certificate of authorization 7610-08-01-70063-24 was issued to this effect.

From September 1999 to January 2000, RSW-Béroma build its UMCO prototype. It is a plant with a capacity of 175 tonnes per day, using the method of direct cyanidation with gold precipitation by zinc powder (Merrill-Crowe process). Concurrently with the construction of the UMCO, operation of the pit #2 took place between October 1999 and January 2000. This generated 55,000 tonnes of ore and 121,000 tonnes of waste. Added sterile rock extended the tailings pond to an area of 1.8 hectares. The ore was processed in the newly installed UMCO to demonstrate its effectiveness. On 16 September 1999, a plan to restore the Granada mine site at the end of the planned operations was submitted to the Ministry of Natural Resources of Quebec. This plan was approved by the MRNQ November 7, 2000.

2000: From February to October 2000, 27,313 tonnes of ore were processed in l'UMCO Granada. The total production was 2,032 ounces of gold at an average grade of 2.51 g/t Au with a recovery of 92.2%. The UMCO had demonstrated its ability to achieve excellent recovery, despite a relatively low mineral content.

On 19 July 2000, an initial agreement for the sale of sterile Mousseau Tremblay Inc. operated between RN and Aggregates Inc.

On 23 July 2000, the MRN issues in Granada Resources mining lease 852 adjacent, east 813 mining lease. 852 mining lease contains extensions to the east of all the veins of the Granada mine.

2001: January 1, 2001, the company merged Granada society Mousseau Tremblay Inc. Granada mining property was transferred to Mousseau Tremblay Inc. and becomes the sole owner of said property.

Fall 2001, the UMCO capacity was increased from 175 to 250 tonnes per day following addition of larger semi-autogenous mill. From December 2001 to March 2002, 24,638 additional tonnes of ore from the pit #2 were treated in the UMCO. Total production was 1,122 ounces of gold at an average grade of 1.80 g/t Au with a recovery of 78.6%. The lower recovery than during the first phase of processing is explained by the lower ore grade.

2003: an intensive waste testing program was instituted to obtain a certificate of authorization to operate waste rock. This certificate was received May 29, 2003. Certificate contained certain covenants that limit the use of waste, especially fine particles less than 2 mm.

2005: the agreement between Mousseau Tremblay Inc. and Agrégats R-N, which allows the latter to exploit the mine tailings of Granada, was renewed on 1 March 2005 for a period of five years, until March 1, 2010.

2006: the Granada UMCO remained inactive from March 2002 to May 2006. Due to a rise in gold prices, the firm Consolidated Big Valley Resources (CBVR) approached RSW-Béroma to buy the UMCO, in early 2006. An agreement was signed in July 2006. Meanwhile, in March 2006, a lease-purchase of the property was signed by Mousseau Tremblay Inc. and CBVR. This agreement allowed CBVR to resume activities that RSW-Béroma was interrupted in 2002. The agreement also provides to CBVR the possibility of buying mining leases 813 and 852 which represent the main Granada mine site. The contract provide use of all facilities available on site (including pit #1 to store the residues resulting from the treatment of ores in CBVR plant) by CBVR.

It should be noted that the firm CBVR changed its name to Gold Bullion Development Corporation (GBDC) in February 5, 2007.

Mining activities resulting from the agreement signed in 2006 between Mousseau Tremblay Inc. and Gold Bullion Development Corporation were as follows:

The UMCO was put into operation on 23 May 2006, with the start shakedown testing. At first, it deals a small amount of ore from the pit #2 (approximately 3,000 tonnes) which had been left behind by RSW-Béroma at the end of its operations in March 2002;

At the same time GBDC began operating Vein #2 in the open pit #2A, located in Test Pit #2 operated by RSW-Béroma in 1999-2000 . At the origin, pit #2A exploitation would generate 50,000 tonnes of ore and 70,000 tonnes of waste. However GBDC decided to use a broader and deeper pit in order to recover some gold veins presenting high in the roof and the wall of the main mineralized zone. Consequently, pit #2A exploitation produced 141,000 tons of ore and 288,000 tonnes of waste. Ore pit #2A was treated in the UMCO at the rate of 250 tons per day;

Waste was added to the existing dumps. The addition of the 288,000 tonnes of waste has the effect of increasing the area of the tailings pond, which rose from 1.8 hectares to 3.2 hectares;

Plant rejects were pumped into the pit #1, after cyanide destruction. At the end of operations RSW-Béroma in March 2002, the pit #1 contained approximately 52 000 tonnes of solid waste occupying a volume of 16,800 m³. This corresponds to approximately 21% of the volume of the pit #1 (80 000 m³) as

measured by RSW-Béroma who performed the complete emptying of 21 September to 21 November 1999. This means that the resumption by GBDC in May 2006, the pit #1 could still accept nearly 196,000 tons of treatment plant rejects;

In addition to the ore from Granada property GBDC planned to eventually treat ore from other mining properties located in Abitibi. To do so, the firm filled in February 2007, a certificate of authorization for the collection of a bulk sample of 40,000 tonnes of the Val St-Gilles property, located north of La Sarre. This ore was sent to Granada and treated in the UMCO.

In May 2007, the MRN accepted the Mousseau Tremblay and RSW-Béroma restoration plan. Gold Bullion paid the deposit guarantee of \$ 171.800 January 23, 2011.

On 3 June, 2009, at the request of Gold Bullion, the 7610-08-01-70063-24 C of A for the operation of the treatment plant is revoked.

On November 25, 2010, Mousseau Tremblay Inc. transfers to Gold Bullion Development Corp. GBDC) all of its 26 mining claims (claims) and its two mining concessions on the mining property Granada.

On 1 February, 2011, Mousseau Tremblay sent to MERN for a certificate of release of Granada mine site and a requested for transfer of responsibility Mousseau Tremblay and RSW-Béroma Gold Bullion pursuant to section 232.10 of the Act mines.

The November 7, 2011, Mousseau Tremblay Inc. wrote a letter to Gold Bullion in which it transfers the rights and privileges conferred by the certificate of authorization 7610-08-01-70063-25 for recovery of waste on the Granada property.

The November 21, 2011, Mousseau Tremblay sent to the MDDEP an assignment of the certificate of authorization. The application closed before conclusion due to lack of information.

In April 2nd, 2012, SGS Canada Inc. produced a resources estimation of the Granada gold project were simply obtained by adding resources in blocks with an estimated grade above any given cut-off. Resource tonnage of a block was: $5\text{m} \times 5\text{m} \times 5\text{m} \times 2.8\text{t}/\text{m}^3 = 350\text{t}$ for a full block (100% below overburden/topo surface).

Granada gold deposit In Situ Resources Estimates are presented in Table 6-1.

Table 6-1: Global classified resources at various cut-offs

Class	Tonnage (,000) tonnes	Au g/t Grade	Au Oz	Cut-off
Measured	100	4.56	14,400	3.0+
	300	3.24	26,300	2.0+
	900	1.88	56,300	1.0+
	1,100	1.74	61,100	0.9+
	1,300	1.59	67,500	0.8+
	1,600	1.46	73,100	0.7+
	1,900	1.30	80,700	0.6+
	2,400	1.16	88,600	0.5+
	3,000	1.01	97,700	0.4+
4,000	0.85	108,100	0.3+	
Indicated	600	4.67	97,500	3.0+
	1,400	3.41	161,000	2.0+
	4,600	1.99	306,300	1.0+
	5,400	1.84	329,700	0.9+
	6,500	1.67	361,500	0.8+
	7,700	1.52	392,400	0.7+
	9,800	1.34	436,400	0.6+
	12,500	1.17	485,200	0.5+
	16,400	0.99	543,400	0.4+
22,700	0.81	614,500	0.3+	
Inferred	1,700	4.48	255,800	3.0+
	2,900	3.60	346,700	2.0+
	6,500	2.35	513,600	1.0+
	7,600	2.16	545,700	0.9+
	9,500	1.90	600,700	0.8+
	10,900	1.74	636,800	0.7+
	13,500	1.53	692,200	0.6+
	17,800	1.30	768,800	0.5+
	23,100	1.10	846,600	0.4+
33,200	0.87	961,300	0.3+	

Note: rounded numbers, base case cut-off >0.4 g/t shadowed. The historical production of 51,476 ounces (181,744 sT @ 0.28 oz/sT) from 1930 to 1935 are included in the resource statement (cannot physically remove from measured, indicated or inferred).

The in situ measured resource was 97,700 ounces (3.02 million tonnes grading 1.01 g/t), indicated resource was 543,400 ounces (17.04 million tonnes grading 0.99 g/t), inferred resource was 846,600 ounces gold (23.93 million tonnes grading 1.10 g/t Au) using a cut-off grade of 0.40g/t.

An in-pit resource within a Whittle-optimized pit shell was estimated using a base case gold price of CAN\$1300 per ounce. The Table 6-2 summarizes the in-pit resources with the selected base case in Whittle optimizations:

Table 6-2: In-pit resources

Classification	Tonnage	Au g/t	Au
	inpit	Grade	Oz
Measured	2,902,000	1.02	95,300
Indicated	12,490,000	1.08	435,600
Inferred	3,403,000	1.24	135,600
Mea+Ind	15,392,000	1.07	530,900

The in-pit estimate was based on a mining cost of CAN\$2.00 per tonne and a processing cost of CAN\$16.00 per tonne (including G&A), assuming gravity cyanidation treatment of the mineralized material, giving base cost of CAN\$29.30 per tonne including stripping. Other assumptions included 94.1% recovery of gold in and pit wall slope angle of 45 degrees in the south footwall and 50 degrees in the north hanging wall.

The selected base case in-pit measured resource was 95,300 ounces (2.9 million tonnes grading 1.02 g/t), indicated resource was 435,600 ounces (12.49 million tonnes grading 1.08 g/t), inferred resource was 135,600 ounces gold (3.4 million tonnes grading 1.24 g/t Au) using a cut-off grade of 0.40g/t based on a Whittle-optimized pit shell simulation using estimated operating costs, a gold price of CAN\$1300 per ounce and a corresponding lower cut-off grade of 0.4 grams per tonne gold.

Remaining underground resources under the selected base case in-pit surface above a cut-off grade of 2.0 g/t is 273,200 ounces (2.32 million tonnes grading 3.66 g/t) are inferred.

Again previous small open pits had been taken into account and were starting surfaces of optimization while the historical production of 51,476 ounces (181,744 sT @ 0.28 oz/sT) from 1930 to 1935 were included in the resource statement.(the author cannot physically remove from measured, indicated or inferred).

In December 21th 2012, SGS Canada Inc produced a second resource estimate for the Granada gold project. Estimated mineral resources of the Granada gold project were simply obtained by adding resources in blocks with an estimated grade above any given cut-off. Resource tonnage of a block was: $5mN \times 10mE \times 5mZ \times 2.7t/m^3 = 675t$ for a full block (100% below overburden/topo surface).

Table 6-3: Global classified resources at various cut-offs

Granada gold deposit In Situ Resource Estimates

Cut-off 0.4 g/t	Tonnage	Au g/t	Au Oz
Measured	28,735,000	1.02	946,000
Indicated	18,740,000	1.09	659,000
Total M+I	47,475,000	1.05	1,605,000
Inferred	29,975,000	1.07	1,033,000
Cut-off 1.0 g/t	Tonnage	Au g/t	Au Oz
Measured	7,810,000	2.14	536,000
Indicated	5,347,000	2.32	398,000
Total M+I	13,157,000	2.21	934,000
Inferred	8,600,000	2.23	617,000
Cut-off 2.0 g/t	Tonnage	Au g/t	Au Oz
Measured	2,533,000	3.76	306,000
Indicated	1,869,000	4.07	245,000
Total M+I	4,402,000	3.89	551,000
Inferred	3,030,000	3.89	379,000

Note: rounded numbers, base case cut-off >0.4 g/t shadowed. The historical production of 51,476 ounces (181,744 sT @ 0.28 oz/sT) from 1930 to 1935 was included in the resource statement (cannot physically remove from measured, indicated or inferred).

The in situ measured resource was 946,000 ounces (28.735 million tonnes grading 1.02 g/t), indicated resource was 659,000 ounces (18.740 million tonnes grading 1.09 g/t), inferred resource was 1,033,000 ounces gold (29.975 million tonnes grading 1.07 g/t Au) using a cut-off grade of 0.40 g/t.

The resource took into consideration the same open-pit shell than the one used on the previous resource estimation report (April 2nd, 2012). In order to have an appraisal of resources within a potential open pit, a Whittle pit optimizer has been run with the following parameters. An in-pit resource within a Whittle-optimized pit shell was estimated using a base case gold price of CAN\$ 1450 per ounce. The Table 6-4 summarizes the in-pit resources with the selected base case in Whittle optimizations:

Table 6-4: In-pit resources

In-pit Estimates*		CoG g/t	Ore M tonnes	Grade g/t	Au oz
Nov 2012 (within claims & Au = 1450 \$/oz)	Measured	0.36	24,992,000	1.01	811,300
	Indicated	0.36	9,336,000	1.18	354,600
	Inferred	0.36	449,800	0.77	11,100
	Mea+Ind	0.36	34,328,900	1.06	1,166,000

*Rounded numbers

The in-pit estimate is based on a mining cost of CAN\$2.00 per tonne and a processing cost of CAN\$16.00 per tonne (including G&A), assuming gravity cyanidation treatment of the mineralized material. Other assumptions include 94.1% recovery of gold in and pit wall slope angle of 45 degrees in the south footwall and 50 degrees in the north hanging wall.

The selected base case in-pit measured resource was 811,300 ounces (24.992 million tonnes grading 1.01 g/t), indicated resource was 354,600 ounces (9.336 million tonnes grading 1.18 g/t), inferred resource was 11,100 ounces gold (0.449 million tonnes grading 0.77 g/t Au) using an effective cut-off grade of 0.36 g/t based on a Whittle-optimized pit shell simulation using estimated operating costs, a 3 year trailing average gold price of CAN\$1450 per ounce and a corresponding lower cut-off grade of 0.36 grams per tonne gold.

Again; previous small open pits had been taken into account and were starting surfaces of optimization while the historical production of 51,476 ounces (181,744 sT @ 0.28 oz/sT) from 1930 to 1935 were included in the resource statement.(the author cannot physically remove from measured, indicated or inferred).

On 14 May 2013, Mousseau Tremblay sent to MDDEFP a new transfer requested in Gold Bullion Certificate 7610-08-01-70063-25 authorization for recovering the sterile. Gold Bullion refused the transfer of C of A to reapply for the treatment of C of A by gravity tailings for less than 2mm.

During the summer of 2013, RSW-Béroma finished dismantling its factory in accordance with the terms of the agreement of 14 November 2006 concerning the rental of its factory in Gold Bullion.

On 15 May 2013, the company Galarneau sent a certificate request for a crushing and enhancement of the mine site tailings stored on the Granada property .C of A Galarneau was granted in May 2014.

7 Geological Setting and Mineralization

Parts of this section were summarized from previous reports mainly *D. Robinson, October 2006* and *Couture, et al., 1997* after validation for accuracy with additional opinions and observations of the author.

7.1 REGIONAL

The Granada Mine property lies within the Abitibi Greenstone Belt of the Superior Province (Figure 7-1 and Figure 7-2). The oldest rocks in the immediate area are schists and migmatites belonging to the Pontiac Group. These are located from 100-200 metres south of the property. They are overlain by conglomerates, sandstones and siltstones of the Temiscaming Group. The contact between the latter and Temiscaming sediments exposed for over 400 m as an intensely altered 10-75 m wide shear zone. This group is capped by the Larder Lake Break rocks comprising carbonate rocks, talc-chlorite and chlorite, and minor sandstone interbeds. The Larder Lake Break rocks were laid down on Temiscaming paleosurfaces and thus belong to that group. The Temiscaming Group is in contact to the north with the Blake River Group. The contact area is composed of clastic sedimentary rocks (source to the south) with intercalated volcanoclastics and sediments derived from Blake River volcanism.

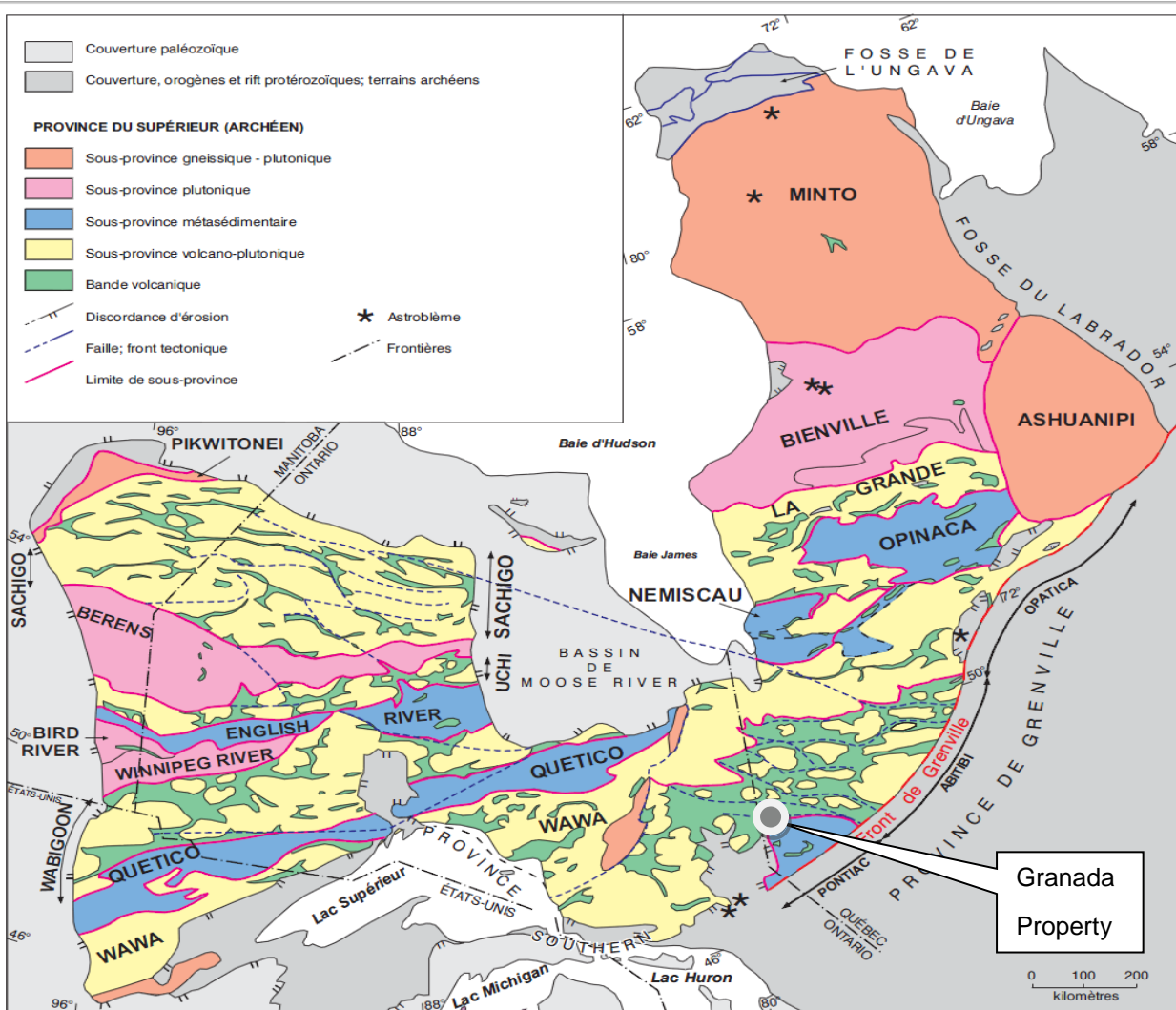

Figure 7-1: Geological map of the Superior Province showing the position of the Property

The base map was taken from the [MERN website](#).

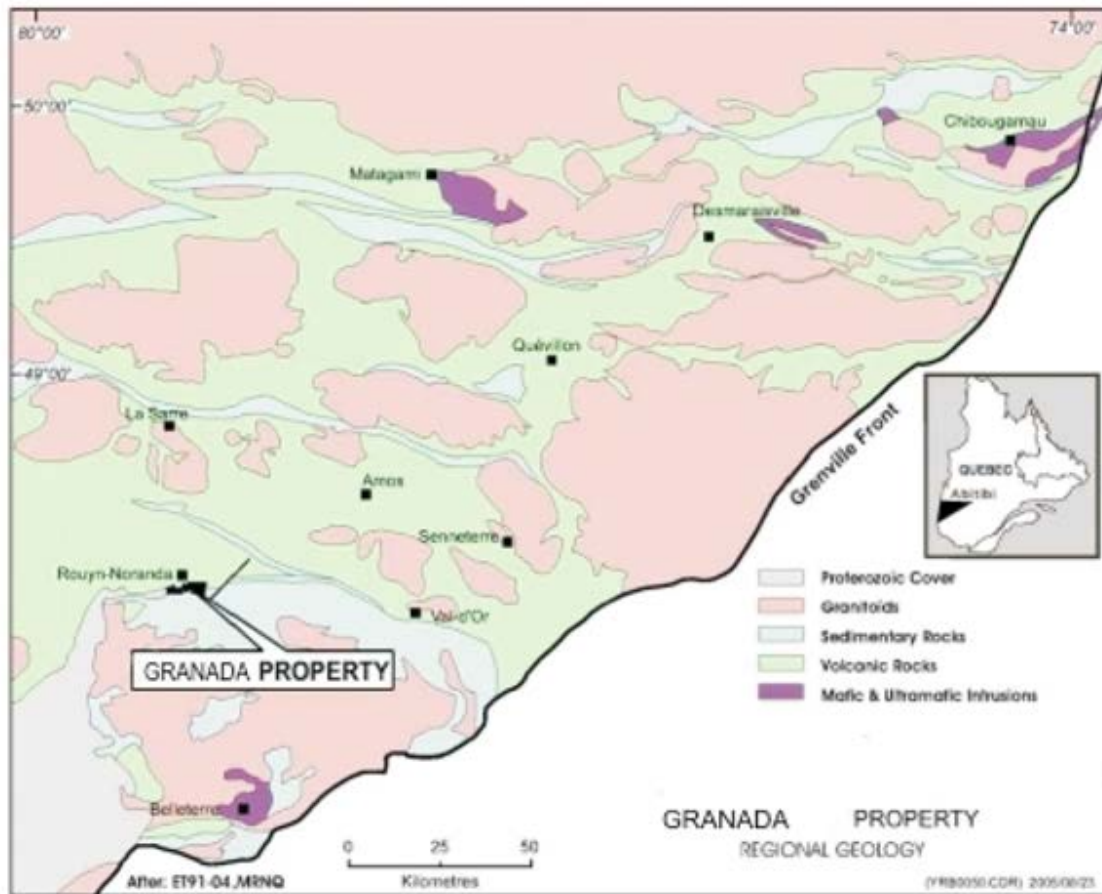

Figure 7-2: Regional geology (after ET91-04, MRNQ)

7.2 LOCAL

The Granada Mine property is situated within rocks of the Temiscaming group, on the south limb of the regional east-west trending Granada synclinorium whose axial trace is located south of the Cadillac Fault (Figure 7-2). The property is underlain principally by east-west-trending, north-dipping interbedded-polymictic conglomerate, porphyry-pebble conglomerate, greywacke and siltstone-mudstone of the Granada Formation. It has been reported by Wilson in 1962 that the conglomerate units had different fragment compositions on opposing limbs of the Granada synclinorium. Conglomerate on the north limb (La Brure Formation) is characterized by jasper fragments which are absent from the south limb and contain scattered magnetite pebbles (Granada Formation).

The Granada Formation is intruded by northerly-trending Proterozoic diabase dykes, felsic dykes, sills and stocks. Sill-like syenitic bodies are concentrated throughout the immediate area of the mine property. The syenite bodies are aphyric to porphyritic with up to 10% tabular centimetre-scale feldspar phenocrysts in an aphyric to slightly porphyritic groundmass. The syenite bodies are slightly oblique (040°-050°) to bedding (050°-060°) and exhibit schistosity (045°-060°). On alkali-silica diagrams the syenitic bodies show four compositional facies: monzonite, syenite, quartzmonzonite and granite, similar to that of most other Temiscaming intrusive rocks from Ontario as sourced from Siriunas, 1994, in previous report. The

principal structural feature in the area is a penetrative schistosity affecting all lithologies. This fabric is usually parallel to stratigraphy. The flattening intensity of pebbles and cobbles increases from south to north towards the Cadillac Fault. Locally, the intensity of the regional schistosity strengthens into discrete shear zones that are emphasized by hydrothermal alteration. In the area of the mine workings, there is a prominent zone of deformation, hydrothermal alteration and quartz veining which extending over 5 km. Figure 7-3 presents the local geology with the historic property outline (much smaller than the current property).

Structural analysis from outcrop data indicate that the Temiscaming sedimentary rocks are isoclinally folded about east-west trending, with a gently east plunging fold axes. This early fold pattern has been subsequently modified by a set of north-westerly trending folds. A series of late northeast trending faults horizontally offset the stratigraphy, the quartz veining and the alteration by a magnitude of 30-50 m typically displaying a dextral motion but sinistral is also observed. All the lithologies in the area of the Granada property, with the exception of the Pontiac Group, are metamorphosed to greenschist facies.

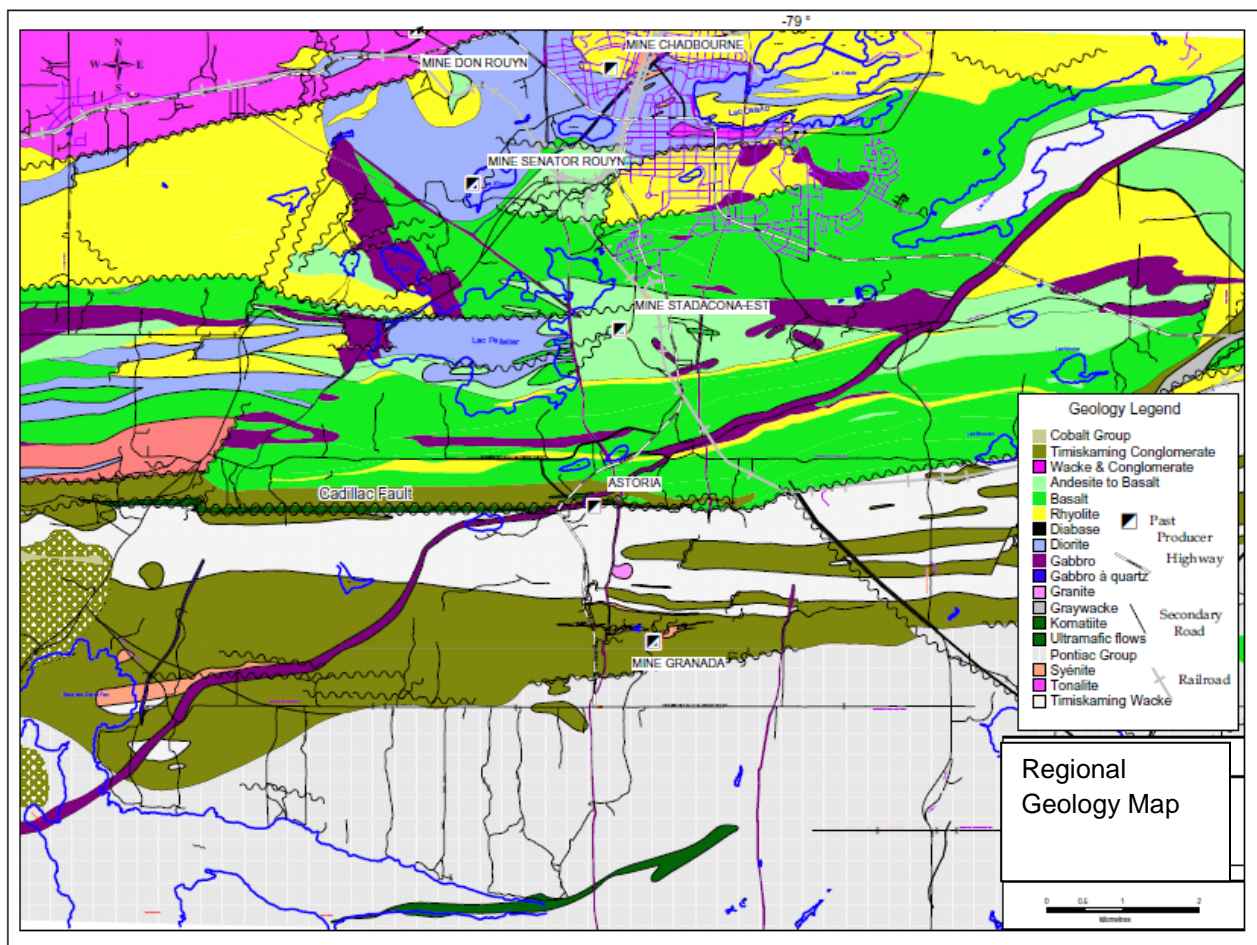

Figure 7-3: Regional Geology Map (previous report of 2006 - from MRNQ)



Figure 7-4: Property Geology with claims boundary (2012) and company recent drillholes



Figure 7-5: Property Geology with claims boundary of 2012 (geology from MRNQ)

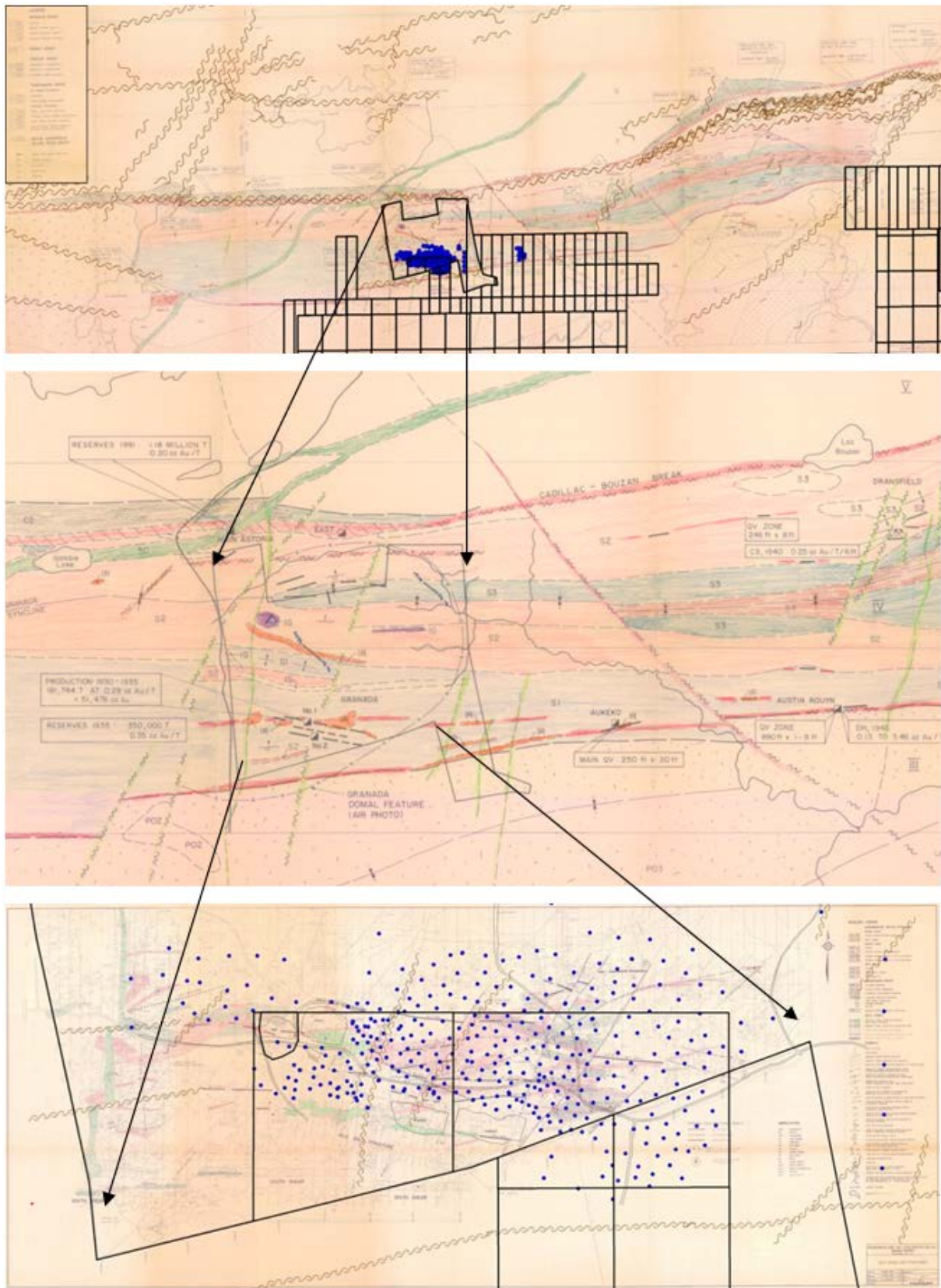

Figure 7-6: Local geology from historical compilation map with GBB holes and property

7.3 PROPERTY

The Cadillac Fault traverses the northern part of the property. Within the Granada mine site itself a parallel set of shears (Granada Shear Zone) occur over a zone of 500 m in width. The shears are characterized by intense sericite, iron carbonate plus minor chlorite alteration with disseminated pyrite and arsenopyrite and host quartz veins and stringers. The veins comprise boudinaged or en-echelon quartz lenses within the sediments and more continuous veins in the syenite intrusive bodies. A series of northeasterly trending sigmoidal faults occur between the Cadillac Fault and the Granada Shear Zone due to late shearing. This late shearing also imparted the fracturing and dilatancy in the quartz veins (Howe, 1994). The following figure presents mapping and geological interpretation of individual veins and mineralized zones with the trace of the NNE faults showing with displacement of the mineralized zones accordingly.

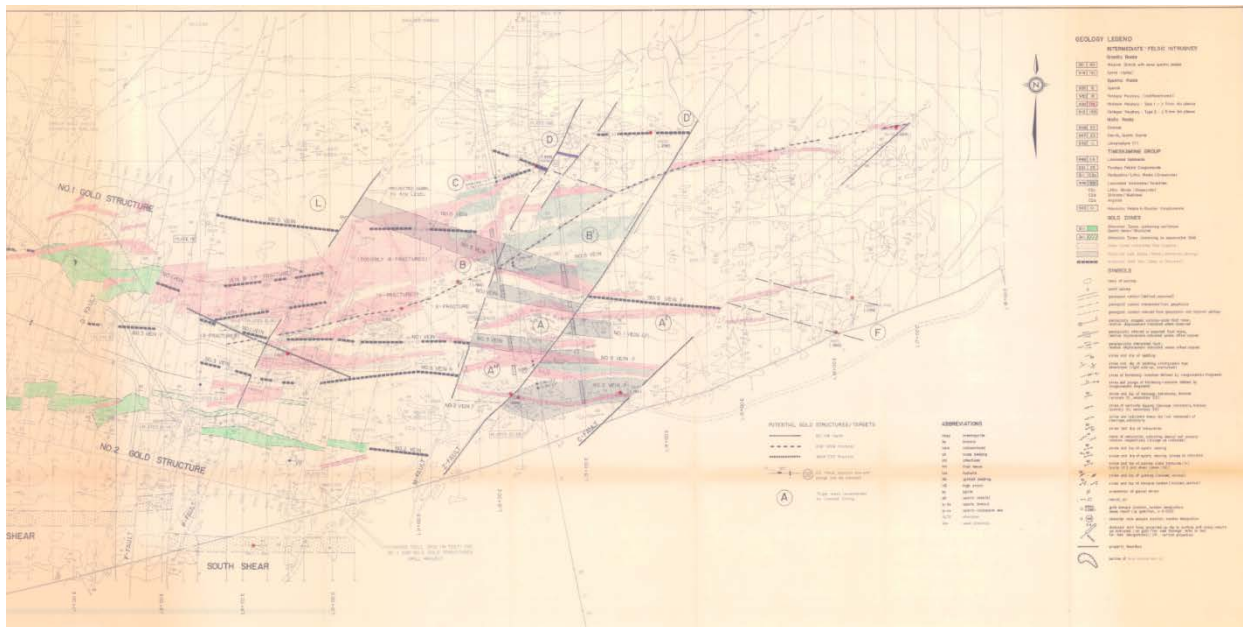

Figure 7-7: Detailed mapping and geological interpretation in plan by KWG in 1992

Exploration works prior to Gold Bullion acquisition aimed at defining resources with the individual veins and thin mineralized structures.





Figure 7-8: Core reference library (partial) as prepared by previous consultants

7.4 MINERALIZATION

7.4.1 GENERAL

As presented in the Figure 7-8, gold mineralization is hosted by east-west trending smokey grey, fractured quartz veins and stringers. Free gold occurs at vein margins or within fractures of the quartz veins or sulphides. Late northeasterly-trending sigmoidal faults also host high grade gold mineralization. Accessory minerals include tourmaline, carbonate, chlorite, and disseminated sulphides. Pyrite is the dominant sulphide typically occurring within the immediate wall rock to the quartz veins. Minor pyrite does occur within the veins themselves. Additional sulphides such as chalcopyrite, arsenopyrite, sphalerite and galena are present in trace amounts. Fuchsite (chromium mica) is present in the immediate wall rock to the quartz veins.

7.4.2 DESCRIPTION OF MORE RELEVANT VEINS AS PER HISTORICAL WORKS

7.4.2.1 Vein #1

Vein # 1 was the original discovery vein on the property. It extends for 600 m across the property. Vein width can vary from greater than 1 m to a couple of centimetres. Gold grades are very erratic from nil to greater than 100 g/t Au. Shaft #1 was sunk to exploit this vein during the underground operations of 1930-1935. The vein only contributed to approximately 5% of the gold production during this period due to the vein's erratic grade. The vein was later the target of open pit operations by KWG Resources during 1993 and 1994.

7.4.2.2 Vein #2

Vein #2 is more correctly described as a mineralized zone of two parallel quartz veins, one in the hanging wall and the other in the footwall, separated by a zone of millimetre-scale quartz veinlets in altered conglomerate. The two main veins are lenticular, locally measuring greater than 1 m in width with metre-scale portions thinning to several centimetres. The hanging wall vein is generally thicker, more continuous and of higher grade (6 to 10 g/t Au) than the footwall vein. The hanging wall vein, plus associated veinlets and pyritic alteration halo averages 3 m in thickness. The intervening zone of quartz veinlets averages 5 m in width and is locally auriferous in the order of 0.7 to 0.8 g/t Au. The footwall vein is generally boudinaged with associated veinlets and pyritic alteration halo averaging 2 m in thickness yielding on average assay

grades of 4 to 5 g/t Au. The entire vein #2 zone averages 10 m in width averaging 3.5 to 4 g/t Au. This vein system was the principal sources of ore for the historical underground operations and open pit production for KWG Resources. The bulk of the historical underground production came from this zone. The heterogeneous distribution of gold grade along strike within the Vein #2 zone resulted in the selective mining of the zone from two shallow pits by RSW-BÉROMA in the year 2000. A western extension of the #2 zone was partially drill defined by KWG Resources in 1995 with the proposed pit referred to as 2B. RSW-BÉROMA calculated a non NI 43-101 compliant geological resource of 28,501 tonnes at 2.4 g/t Au (Trudel, 2000).

7.4.2.3 Vein #3

Vein # 3 was discovered during underground exploration by KWG Resources while drifting on the fifth level between Vein #1 and #2. It is described as a large shear zone containing numerous quartz veinlets hosting free gold.

7.4.2.4 Vein #5

Vein #5 is the most continuous vein of the Granada property. It has been traced by drillholes from surface to the seventh level of the mine (213 m vertical). It is hosted within the conglomerate along the northern contact with a porphyritic syenite sill. On surface, trench samples of Vein #5 yielded weakly anomalous assays of 0.51 g/t Au over 15 m. Underground development reported visible gold when the vein was encountered.

7.4.2.5 Vein A & B

Both Veins A and B were discovered after underground operation ceased. Little descriptive information is available for these zones. Vein A outcrops on surface just east of the waste rock pile at 900E and 425N in a trench.

7.4.3 THE NEW APPROACH – THE GBB APPROACH

Gold Bullion's first approach was to look at developing the property as an open pit large tonnage with lower grade operation instead of mining individual veins. The higher value of gold supports this approach. The drilling and exploration focused on drilling the whole mineralized package and analyzing all material between the veins. An Example of coarse gold observed in a small vein at Granada in drillhole GR-10-62 is pictured in Figure 7-9.

The mineralization zones in this report include the veins, the stockworks, the alteration zones with disseminated gold in sulphides is shown in the typical cross-sections in the following figures.

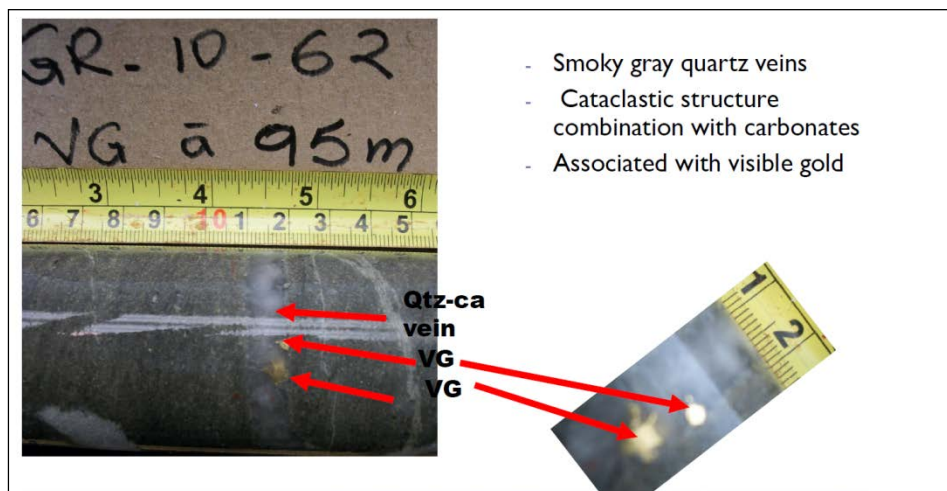

Figure 7-9: Gold mineralization in Quartz vein

The gold grade at Granada varies due to coarse free gold in the mineralized structures. Apparently discontinuous, the mineralized structures are relatively continuous as demonstrated by assay grade continuity on the following cross section and the geometry of the underground workings. Due to the continuity of the structures, it was decided to remodel the mineralization in thin, higher-grade zones for more concentrated mining as shown in Figure 7-12.

The mineralized zones are being cut in blocks which are shifted in majority to the north.

In cross-sectional view such as Figure 7-11 presenting section 18 east of shaft #1, the extent of the vein is over 250 m and supported by drillhole data. An important point to mention is the fact that previous operators did not extract all the gold. It is possible to see the drift projection in grey into the foot wall vein.



Figure 7-10: Example of visible gold occurrences at Granada

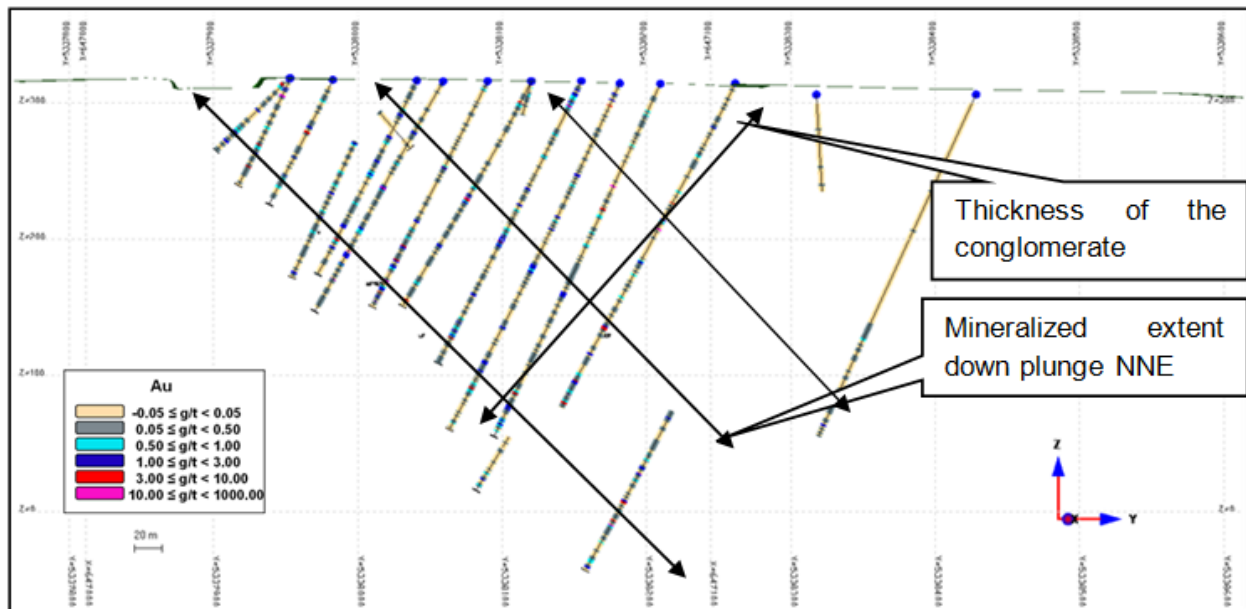

Figure 7-11: Cross-section (SESFT 18) showing grade continuity looking 283N with 25 m corridor.

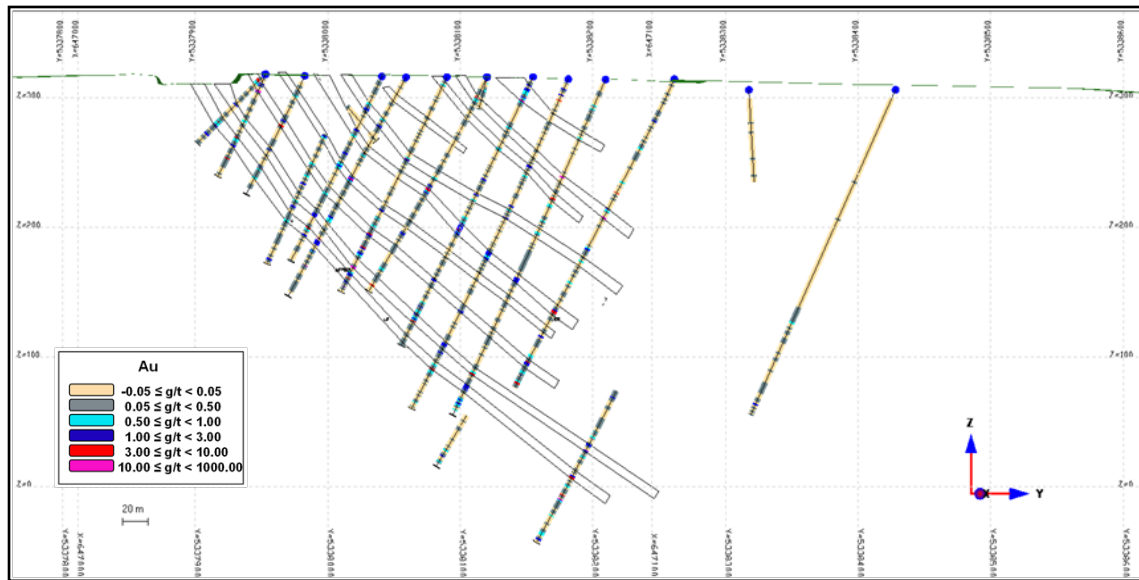

Figure 7-12: Cross-section (SESFT18) with mineralized structures looking 283N with 25 m corridor.

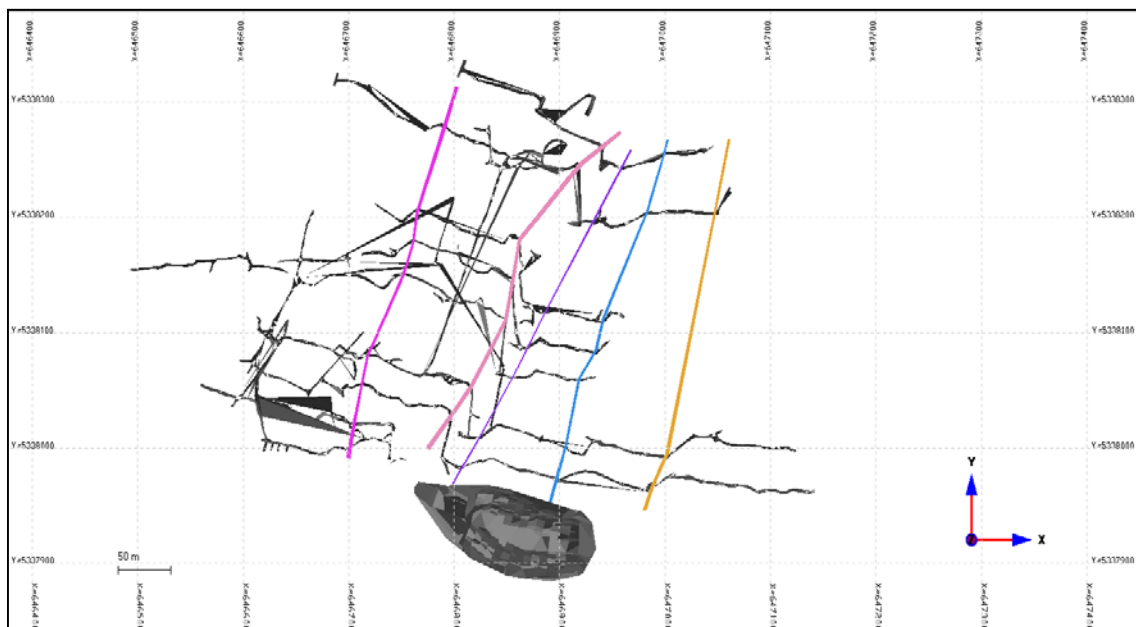

Figure 7-13: Plan view of historical drift and pit #2 with trace of NNE faults in colors.

The above figure demonstrates the segmentation of the mineralized zones between faults. Adding together the segments shows a length in the order of 540 m in an easterly direction from historical workings. With the additional 2012 drilling this mineralized length was increased to 1100 m. The old workings also show the existence of mineralization 500 m down plunge as shown in previous cross-sections.

The sub-vertical NNE faults affect the plunge and the author believes it is steeper with depth as per historical records of fault intersections in underground workings and observations in cross-sections.

The thickness of the conglomerate unit hosting the mineralized zones is over 300 metres. Within this package, it has been possible to observe different distinct mineralized zones with disseminated gold grades between the zones as shown in the previous cross-sections (Figure 7-11 and Figure 7-12).

Most of the economic mineralization on the Granada property is related to late quartz veining. Several sets of veins have been recognized on the property. From north to south, historically the more important vein sets are referred to as: 5, B, A, 1, 3 and 2. The veins trend generally east-west direction and dip between 35° to 50° to the north. They are sub-concordant with sedimentary contacts. Quartz veins within syenite dykes and sills tend to follow the trend of the unit. The author has observed gold grains along a cobble from conglomerate surface outcrop within a dilatation zone across the schistosity. Mineralization is also associated with the presence of porphyry.

A portion of the gold occurs as free coarse gold while the remaining is mostly associated with sulphides. Additional discussion on the gold characteristics can be found in the section 13 of this report.

8 Deposit Types

The Granada deposit is a quartz-vein mesothermal gold deposit hosted by late Achaean Temiscaming sedimentary rock and younger syenite porphyry dykes dated at 2673 ± 3 Ma as per works by Davis in 1991. The dykes belong to a late tectonic alkaline magmatic suite that hosts the mesothermal gold mineralization in the Kirkland Lake and Timmins gold camps of Ontario and also of Duparquet which is north of Rouyn-Noranda, in the Province of Quebec. The mineralization is mainly confined to the conglomerate/greywacke package of event S1 of the Granada Formation as shown in Figure 8-1.

The exploration model consists of shallow gold resources realistic to initiate open pit mining while extension at depth of the high grade structures continues to be tested for eventual underground operation.

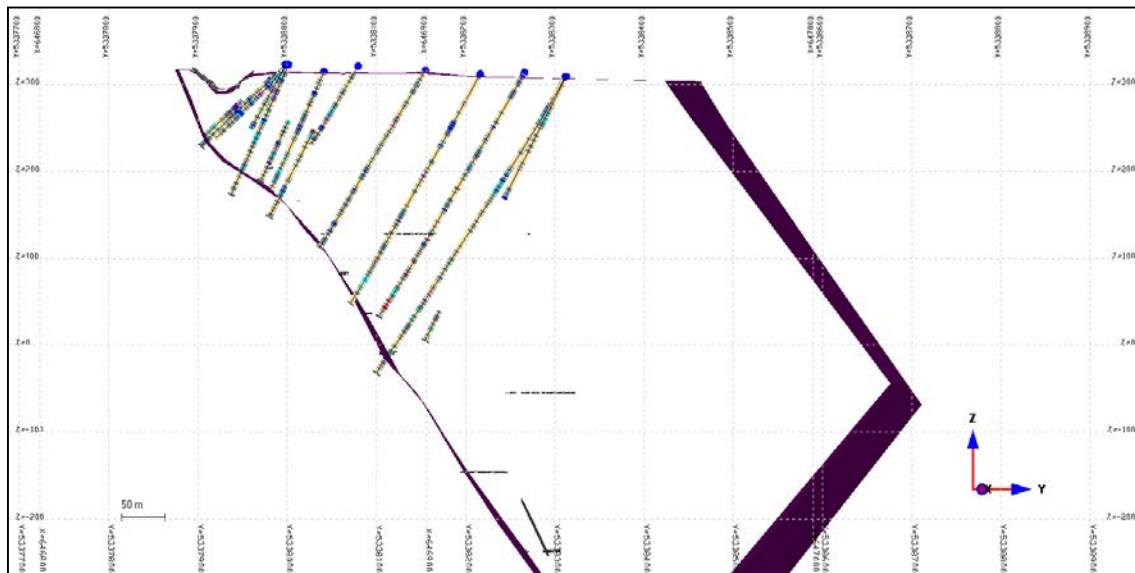

Figure 8-1: Outline of the mineralized conglomerate package being investigated in purple



Figure 8-2: Typical conglomerate S1 unit on surface

9 Exploration

The company had requested an analysis of the mineral potential across the property by spectral analysis. The company carried out geological and structural studies of its D2 D3 group which are Gold Bullion properties in Rouyn-Noranda area. These studies were performed by EarthMetrix Technologies Inc.

Photonic Knowledge studied Granada drill cores with the objective of assisting in the interpretation and localization of mineralized and alteration zones using spectrometry. The company also completed a bulk sample in 2007.

9.1 GEOLOGICAL & STRUCTURAL STUDY BY EARTHMETRIX

On behalf of Gold Bullion Development Corp., a geological and structural study has been realized on the D2D3 group of properties (see Figure 9-1) using available data including assessment work files coming from the MRNF (Quebec), satellite imagery and data covering the property coming from different sensors (including SPOT-5 and WorldView-1) compiled by Technologies EarthMetrix inc. between January 2011 and June 2011.

The D2D3 Group of Properties consist of 3 separate claims blocks totaling 107.33km²: Kekeko South property (12.95 km²) in Beauchastel and Montbeillard townships, Beauchastel Syenite property (49.23 km²) in Beauchastel, Rouyn, Montbeillard and Bellecombe townships, Adanac Extension property (45.15 km²) in Rouyn, Joannes and Bellecombe townships. The D2D3 Group of Properties are situated just southwest, south and southeast of the town of Rouyn-Noranda (downtown) in Abitibi-Temiscamingue (NTS Sheet Map 32D02/32D03). Major secondary roads and all weather gravel roads traverse the properties.

The main objective of this study was to determine optimal exploration targets for the discovery of significant gold mineralization on the D2D3 group of properties from available data (Assessment work files from the MRNF), structural interpretations using the technology developed by Technologies EarthMetrix Inc. by integrating all results coming from different interpretations. Maps are defined by the property limits.

This report presents results obtained from this study, mainly exploration targets areas that should be considered for more detailed exploration on the D2D3 Group of properties. Alain Moreau has briefly visited the properties in June 2011.

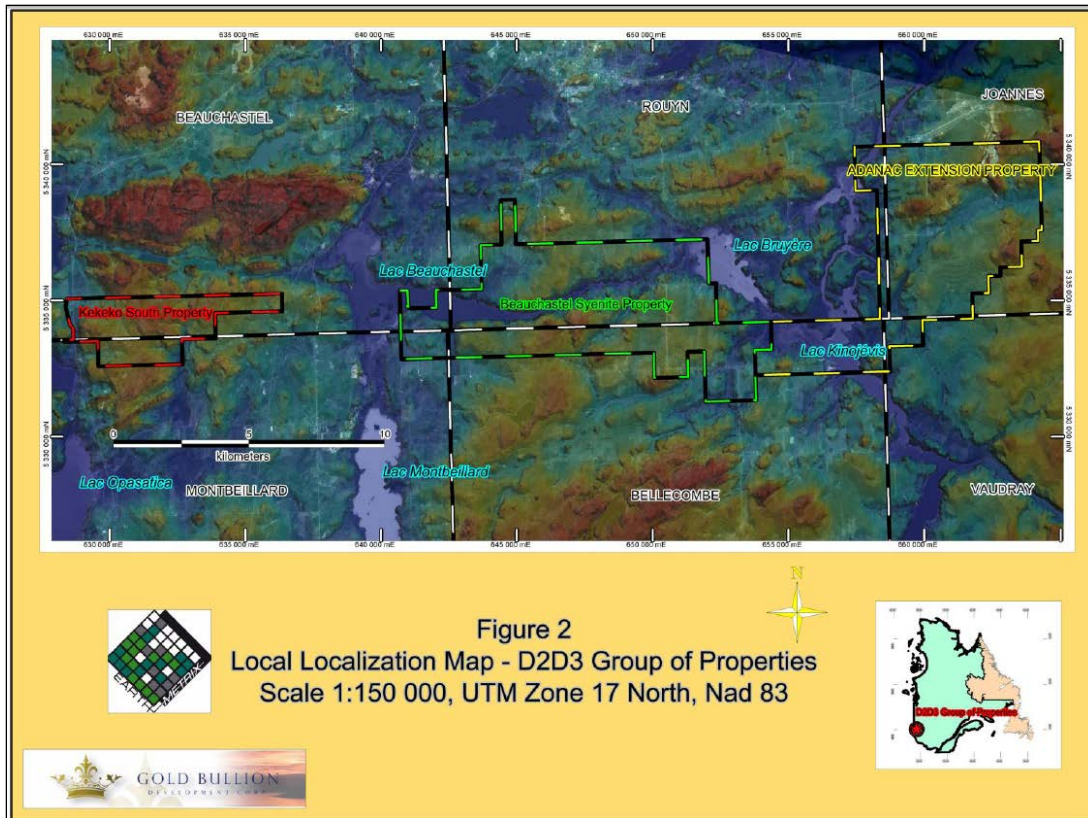

Figure 9-1: Sector where the work was performed

The result of this investigation presents targets which are summarized in the following maps (Figure 9-2 and Figure 9-3) for the two sectors within the Granada property under study.

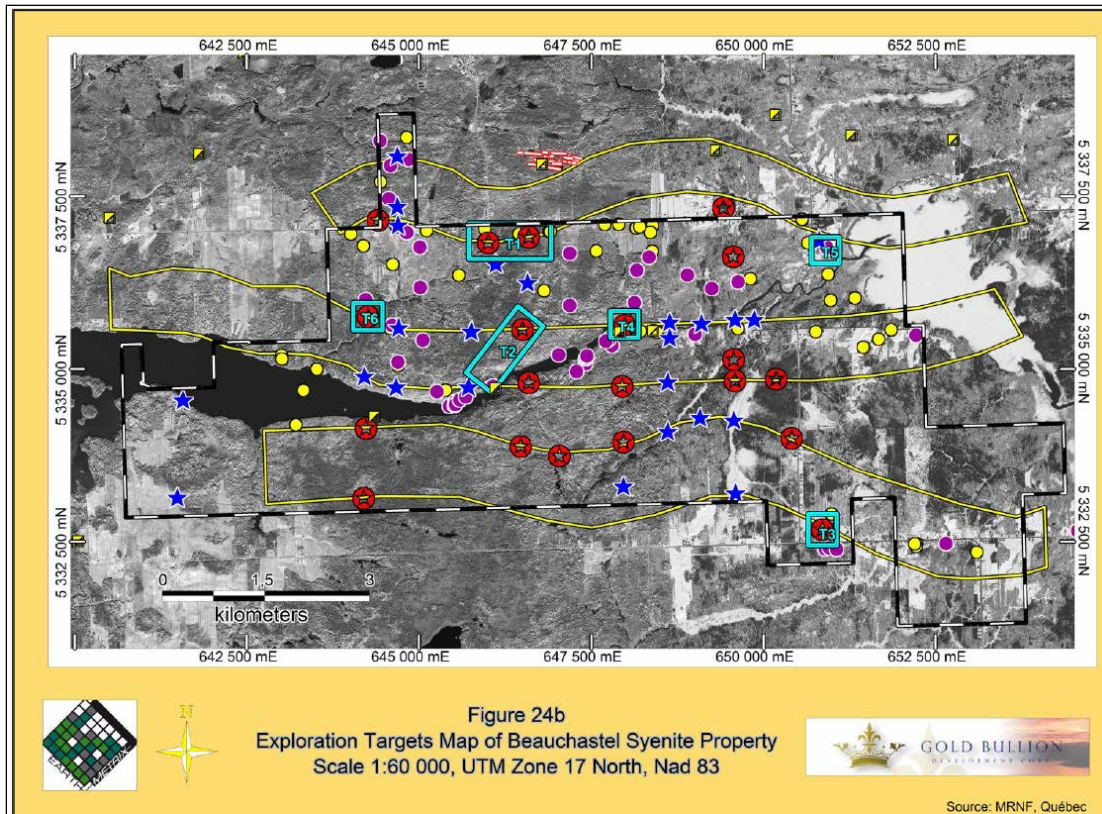

Figure 9-2: Exploration targets map from EarthMetrix Beauchastel Syenite sector

The analysis of spectral information combined with data compilation of historical works has allowed EarthMetrix to provide the company with exploration targets outside the known Granada mine zone.

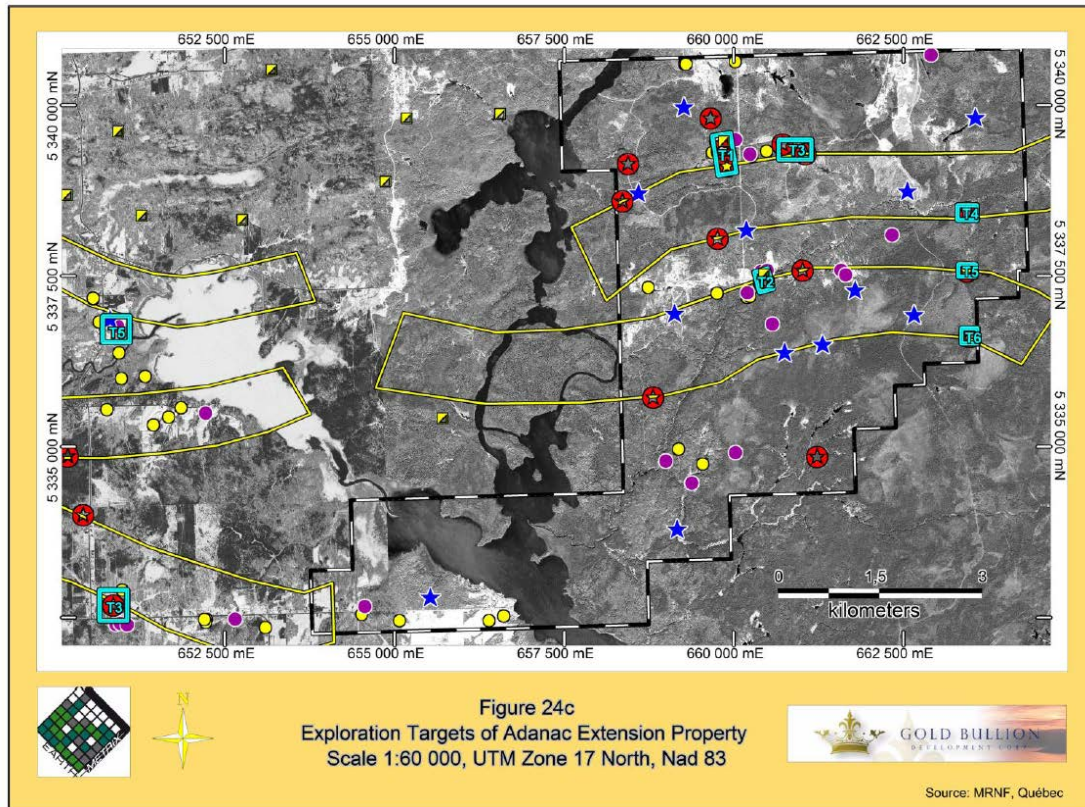

Figure 9-3: Exploration targets Map from EarthMetrix Adanac Extension sector

The list of targets will have to be visited in the field prior to drilling and this will be included in the recommendation section.

To the authors' knowledge, other than a limited stripping and surface mapping north of existing pit #2 no significant rudimentary exploration work has been conducted; not including exploration drilling.

9.2 BULK SAMPLE 2007

A 140,000 tonnes bulk sample was processed by Gold Bullion in 2007 from an open pit at the Granada Mine, of which 30,000 tonnes were processed using an on-site mill. The average gold grade from this large sample was 1.62 g/t with a 90-percent rate gold recovery. The waste from this bulk sample, along with the waste stockpile from past bulk sampling programs at the Granada mine by previous operators were also assayed and returned an average grade of 1.75 g/t Au. This confirms the presence of gold mineralization between the vein structures, which trend east-west as one large overall structure.

The Company management claim that the bulk sample and Phase 1 drill results confirmed that gold at Granada is not just confined to the quartz-carbonate vein network but is also present in significant amounts within the iron-rich sulphurized wall rock (the material between the veins).

The details of the bulk samples were not provided to the author and the numbers could not be verified.

However the author agrees with this disclosure of the company regarding the occurrence of gold mineralization between the main veins at Granada as observed in assay results and visible gold found in drill core.

9.3 EXPLORATION 2007 – 2012

From 2007 to 2012 exploration holes were drilled and are discussed in the drilling section.

9.4 EXPLORATION 2013

In early 2013, SGS discovered shallow high grade zones using assay results from previous exploration campaigns. In May 2013, Gold Bullion Development Corporation contracted SGS Geostat to perform channel sampling on the Granada Gold property. The campaign focused on developing the newly discovered high grade zones identified in the following drillholes: GR-12-413, GR-10-21, GR-11-380, GR-11-313 GR-10-104, GR-10-105, GR-10-125, GR-10-97, GR-10-53 and GR-10-100.

In order to confirm shallow high grade zones, a total of 8 test pits were mechanically shovelled on the property. Pits are located on existing drill pads of the above mentioned holes. Excavation was done to bedrock at each pit in order to take samples. Sample channels were drawn to cross the mineralized zone (identify as Quartz Veins zone) and neighbouring sterile zones. Channels were divided in 1 metre samples, surveyed and sent to Accurassay laboratory for XRF analysis. For QA/QC validation, 3 blanks and 2 standards were inserted. A total of 53 samples (including blanks and standards) were sent to the lab.

Assays from channel samples taken from the trenched areas varied from 22.42 g/t Au over 1.04 metres to 0.01 g/t Au over 0.82 metres. The higher grades were from samples in the eastern section of the extended LONG Bars zone. Significant visible gold was also encountered very near surface (at a depth of 10 centimetres) in the western area of the trenching.



Figure 9-4: Channel sampling, 1 metre intervals TP-13-07

10 Drilling

The Company has carried out three phases of exploration starting in 2009, another in 2010 and the third in 2011. All exploration work, especially drilling has been done under supervision and management of the Company's previous consultant. The drilling was done by a diamond-drill using NQ core size.

10.1 PHASE 1

The company drilled 25 shallow holes in the Phase 1 drill program (see Figure 10-1) from December 2009 to January 2010 at the Granada Gold Property. A total of 2,817 metres was drilled and was successful at testing for structures. The program also revealed a possible substantial new discovery of shallow depth mineralization northeast of the historic and past producing Pits #2 West (Pit 2A) and #2 East (Pit 2B).



Figure 10-1: Layout of the phase 1 drilling campaign

Drilling highlights include drillhole GR 10-17 located over 300 metres from the edge of Pit #2 East, intersected 65.5 metres of 1.21 g/t Au gold (from 3.5 to 69 metres depth) within a wider interval grading 0.95 g/t Au over 99.2 metres. This hole, reported March 1 2010, was collared 103 metres southeast of GR-10-15 which returned 73.8 meters of 0.88 g/t Au as reported February 8 2010.

Three (3) other Phase 1 holes in the company named “LONG Bars Zone Eastern Extension” also came back with encouraging results. GR-10-18, collared 125 metres southwest of GR-10-17, intersected 19 metres of 1.02 g/t Au. GR-10-14 and GR-10-16 returned lower gold values over shorter intersections but confirmed the continuity of mineralization in this newly discovered area. Some highlights of that campaign are:

- GR-10-21 Fifty (50) metres outside the western boundary of the zone and nearly 800 metres from GR-10-17, intersected 65.5 metres grading 0.72 g/t Au (from 3.50 to 69 metres) including 20 metres of 2.20 g/t Au.
- GR-10-13 located between Pit #1 and Pit #2 inside the zone, returned 27.75 metres grading 1.27 g/t Au within a wider interval of 66 metres grading 0.56 g/t Au;

GR-10-12	located north of Pit #2 East and 300 metres southwest of GR-10-17, intersected 68.8 metres of 1.07 g/t Au (from 16.2 to 85 metres) including 44 metres grading 1.54 g/t Au and 14 metres grading 4.28 g/t Au;
GR-09-08	46 metres east-southeast of GR-10-12, returned 32.5 metres of 1.27 g/t Au, also at shallow depth, within a wider interval of 0.92 g/t Au over 51 metres;
GR-09-05	75 metres northeast of GR-09-08, graded 0.92 g/t Au over 31 metres between 92 and 123 metres;
GR-09-02	at the western edge of the waste pile east of Pit #1, returned 32.5 metres of 1.74 g/t Au between 15.5 and 48 metres;
GR-09-01	25 metres north of GR-09-02, intersected 14.7 metres of 1.60 g/t Au over a wider interval of 61.7 metres averaging 0.56 g/t Au between 6.3 meters and 68 metres

10.2 PHASE 2/PHASE 3 DRILLING

The Company launched a 20,000 metre Phase 2 drill program at the Granada Gold Project in early May 2010, which was extended by 5,000 metres in September due to encouraging early results. The two-pronged strategy was to both a) conduct infill drilling as well as further exploratory drilling within the main zone as a first step toward an eventual NI 43-101 compliant resource estimate and b) significantly expand the overall LONG Bars Zone mineralized area. Some deeper drilling was also planned, and has taken place, within both the main zone and the Eastern Extension in order to test the Granada structure at depth. This was done in part since most drilling at the property both historically and in Gold Bullion's Phase 1 program has been shallow (predominantly less than 100 metres vertical depth).

Gold Bullion Development has completed nearly 11,000 metres of Phase 3 drilling at its Granada Gold Property as of January 21, 2011, with Phase 2 and Phase 3 drilling intersecting new mineralized structures throughout the LONG Bars Zone (main Granada mineralized structure package). From that drilling mineralization remains open in all directions at Granada.

In November 2011, Gold Bullion reported the discovery of significant mineralization northeast and southeast of its LONG Bars Zone and the Granada Gold Property as a whole.

GR-10-108, collared 30 metres north of GR-10-55, delivered the longest mineralized intersection to date at Granada (356.6 metres @ 0.60 g/t Au), returned an interval of 141.7 metres grading 0.70 g/t Au.

One of the goals of Phase 3 drilling was to expand the continuity of the feldspar porphyry and quartz veining in this particular area. GR-10-108 was collared 150 metres northeast of the main zone.

Meanwhile, nearly 500 metres south of GR-10-108, GR-10-86 returned 84.6 metres grading 1.00 g/t Au within a total near-surface interval of 127.5 metres (4.5 metres to 132 metres) grading 0.76 g/t Au as reported November 19, 2010. This hole was drilled toward the south and was collared approximately 180 metres southeast of Gold Bullion's Preliminary Block Model. The discovery of near-surface mineralization in the deep-south of the Eastern Extension is considered a significant development.

All Phase 2 drilling was completed by late October 2010 and more than 20% of the Phase 3 program was completed by January 21, 2011.

Gold Bullion reported September 9, 2010 that their previous geological consultant had observed visible gold and disseminated sulphides, along with large alteration zones, within feldspar porphyry in numerous holes drilled in Phase 2.

The fact that porphyry is hosting gold is an interesting development for the Granada deposit as a 2006 Technical Report on the property stated that all economic mineralization at Granada was related to quartz veining.

Other results; GR-10-53, collared 88 metres southeast of GR-10-41 and near Pit #2 East, intersected 68.3 metres of 2.16 g/t Au, including a high grade section of 4.60 g/t Au over 26 metres, within a wider near-surface interval of 110.5 metres (3.5 metres to 114 metres depth) grading 1.34 g/t Au. This hole was drilled perpendicular to Vein #2 and is believed to closely approximate true width. Alteration dominated by intense sericitization and silicification was encountered in this hole along with quartz veining and abundant pyrite.

Table 10-1: Selected intersections of interest from Phase 1, Phase 2 and Phase 3 drilling

Drillhole	From (m)	To (m)	Interval (m)	Weighted Gold grade g/t Au
PHASE 1 HIGHLIGHTS				
GR-09-02	15.5	48	32.5	1.78 g/t
including	40.7	41	0.3	96.60 g/t
GR-09-05	92	123	31	0.92 g/t
GR-09-06	36	52.5	16.5	1.22 g/t
GR-09-08	17	68	51	0.93 g/t
GR-10-12	4.3	87	82.7	0.90 g/t
GR-10-13	32.2	59.95	27.75	1.27 g/t
GR-09-15	73.2	147	73.8	0.88 g/t
GR-10-17	3.5	102.7	99.2	0.95 g/t
including	3.5	69	65.5	1.21 g/t
GR-10-18	37.5	56.5	19	1.02 g/t
PHASE 2 HIGHLIGHTS				
GR-10-33	23	146.5	123.5	1.07 g/t
GR-10-41	3.65	153	149.35	0.83 g/t
including	54.9	130	75.1	1.50 g/t
GR-10-53	5	112.5	107.5	1.37 g/t

Drillhole	From (m)	To (m)	Interval (m)	Weighted Gold grade g/t Au
including	8	73.3	65.3	2.14 g/t
GR-10-55	86.64	304.14	217.5	0.95 g/t
including	86.64	271.43	184.79	1.06 g/t
GR-10-79	22.5	185	162.5	0.88 g/t
GR-10-99	3.5	87	83.5	0.98 g/t
GR-10-104	3	231	228	0.51 g/t
GR-10-108	117.58	259.28	141.7	0.70 g/t
including	184.84	259.28	74.44	1.06 g/t
GR-10-113	22.97	252.92	229.95	0.93 g/t
including	232.5	233.59	1.09	162.75 g/t
GR-10-117	3	201	198	0.74 g/t
including	4.6	77.5	72.9	1.02 g/t
GR-10-126	29.1	85.05	55.95	1.01 g/t
GR-10-128	3	116.5	113.5	0.55
including	55.5	116.5	61	0.81
including	60	61.5	1.5	15.7
GR-10-130	2	96	94	1.03 g/t
GR-10-138	116	171.5	55.5	0.77
including	116	125	9	2.16
GR-10-141	3	279	276	0.52 g/t
PHASE 3 HIGHLIGHTS				
GR-10-153	3.9	139	135.1	0.62
including	3.9	80.1	76.2	0.99
including	3.9	4.9	1	54.98
GR-10-157	45.5	116.5	71	1.06

Drillhole	From (m)	To (m)	Interval (m)	Weighted Gold grade g/t Au
including	56.5	61	4.5	3.75
including	69	70	1	44.8
GR-10-169	9	117	108	0.64
including	51	115.5	64.5	1.03
GR-10-173	117.75	356	238.25	0.52
including	253.5	333.5	80	1.36
GR-10-178	193	376.5	183.5	0.5
GR-10-179	3	159	156	0.61
including	50.75	123	72.25	1.25
GR-10-189	99.5	170.4	70.9	1.06
GR-11-199	60	146	86	1.2
including	60	61	1	63.5
and including	129.75	146	16.25	1.86
GR-11-200	50.5	156.5	106	0.81
GR-11-216	1.5	57.6	56.1	0.56
GR-11-223	3.4	54	50.6	0.56
GR-11-231	174.5	227	52.5	0.52
GR-11-235	2.2	150	147.8	0.5
including	6.5	96	89.5	0.78
GR-11-237	42	130	88	0.5
GR-11-256	75	173	98	1.21
including	139	168.5	29.5	2.34
GR-11-271	24.55	207.5	182.95	1.11
including	24.55	25.3	0.75	207.27
and including	71.5	72.5	1	13.71

Drillhole	From (m)	To (m)	Interval (m)	Weighted Gold grade g/t Au
and including	206	207.5	1.5	10.49
and including	206	258	52	0.79
GR-11-287	104	173.5	69.5	1.05
including	110.4	111.3	0.9	30.03
and including	122.5	123	0.5	38.75
and including	172.6	173.5	0.9	15.79
and including	129.6	146	16.25	1.86

Most of the drillholes have been drilled at a roughly perpendicular angle to the veins. The core lengths are generally 85% to 90% of the true width for drillholes drilled south-southwest. The holes which were drilled southeast have approximately 75% true width as per current modelling. The shallow holes are closer to true width; deep holes were drilled on a steeper angle.

The previous consultant responsible for the execution and management of the Phase 1, 2 and 3 drilling campaigns for the Gold Bullion misjudged the amount of work, drilled holes at incorrect orientations, and drilled holes outside the property boundary. The author is confident that most of the hole collars were drilled at the right place and that the core is representative of what is in the ground at Granada. It is important to recall that not all drillholes were used in the current resources estimation; only holes of which the author and his colleagues were able to validate.

Figure 10-2 presents the holes drilled and the holes which have been used in the first resource estimate.

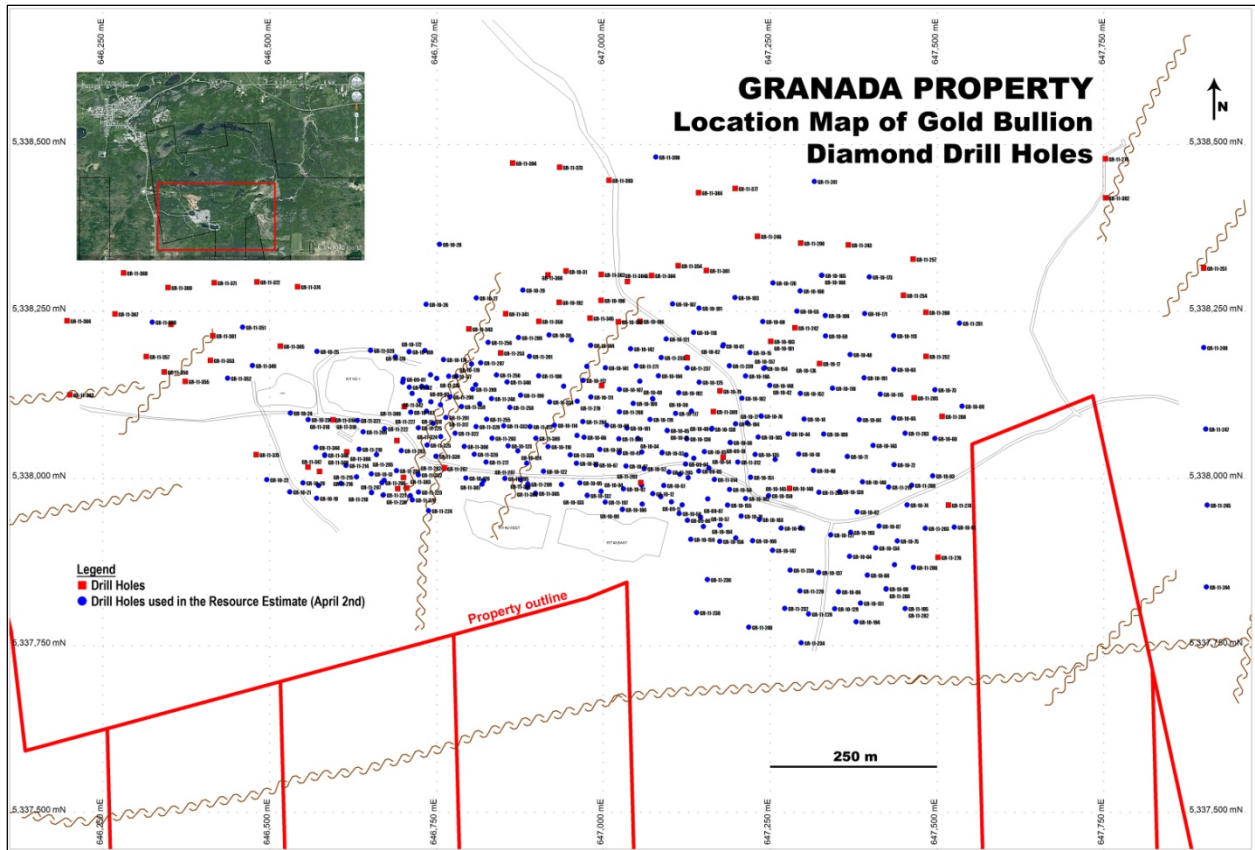

Figure 10-2: Drilling in main Granada mine zone

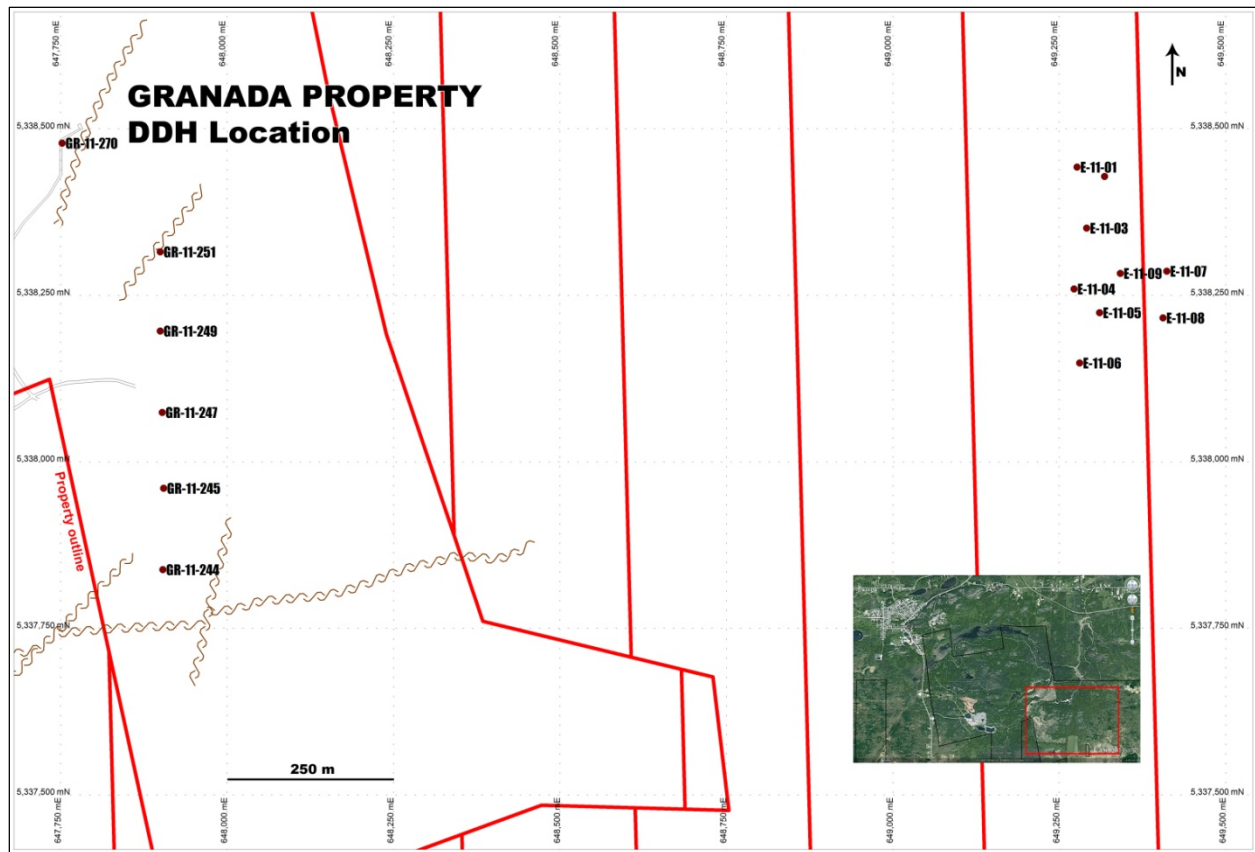

Figure 10-3: Drilling east of Granada mine

10.3 2012 DRILLING PROGRAM - NORTH AND WEST EXTENSION 2012 PROJECT

The deep and shallow drilling programs (Figure 10-4) were initiated by GBB in 2012 under Claude Duplessis recommendation to test structures and gold mineralization presence on the north and west extension of the Granada Property. The spring 2012 drilling program was intended to enlarge the gold mineralization envelope of the expanded LONG Bars zone resource to the north at depth and near surface to the west.

The original drill plan on the northern deep drilling area was designed to have three deep holes (DUP-12-01, DUP-12-02 and DUP-12-03) each hole with one wedge. The program commenced with planned drillhole DUP-12-03. Due to excessive deviation, this hole was consequently abandoned at 378m. In order to continue the drill program, hole DUP-12-03A, located 400 metres NNE (12° North) of hole GR-11-390 was drilled 25 metres to the west of DUP-12-03 to a final depth of 1347 m. Following this, three wedge holes W1, W2 and W3 were placed into DUP-12-03A.

Hole DUP-12-02, located 830 metres NNE (24° North) of hole GR-11-390 was drilled down to 1593 m with one wedge added, W1.

These deep drillholes have expanded the mineralization by 650 metres to the north and an additional 600 metres in depth where the mineralization envelope remains open for expansion.

Due to the success of DUP-12-03A, DUP-12-02 and the associated wedges demonstrating continuation at depth of gold mineralization the drill was reassigned to the western extension to further evaluate near-surface mineralization. Planned hole DUP-12-01 was put on hold for these reasons. The observation of

visible gold and typical alteration zones present in the western extension holes GR-11-375 and GR-11-363 from the backlog program have helped to establish the new targets in this area.

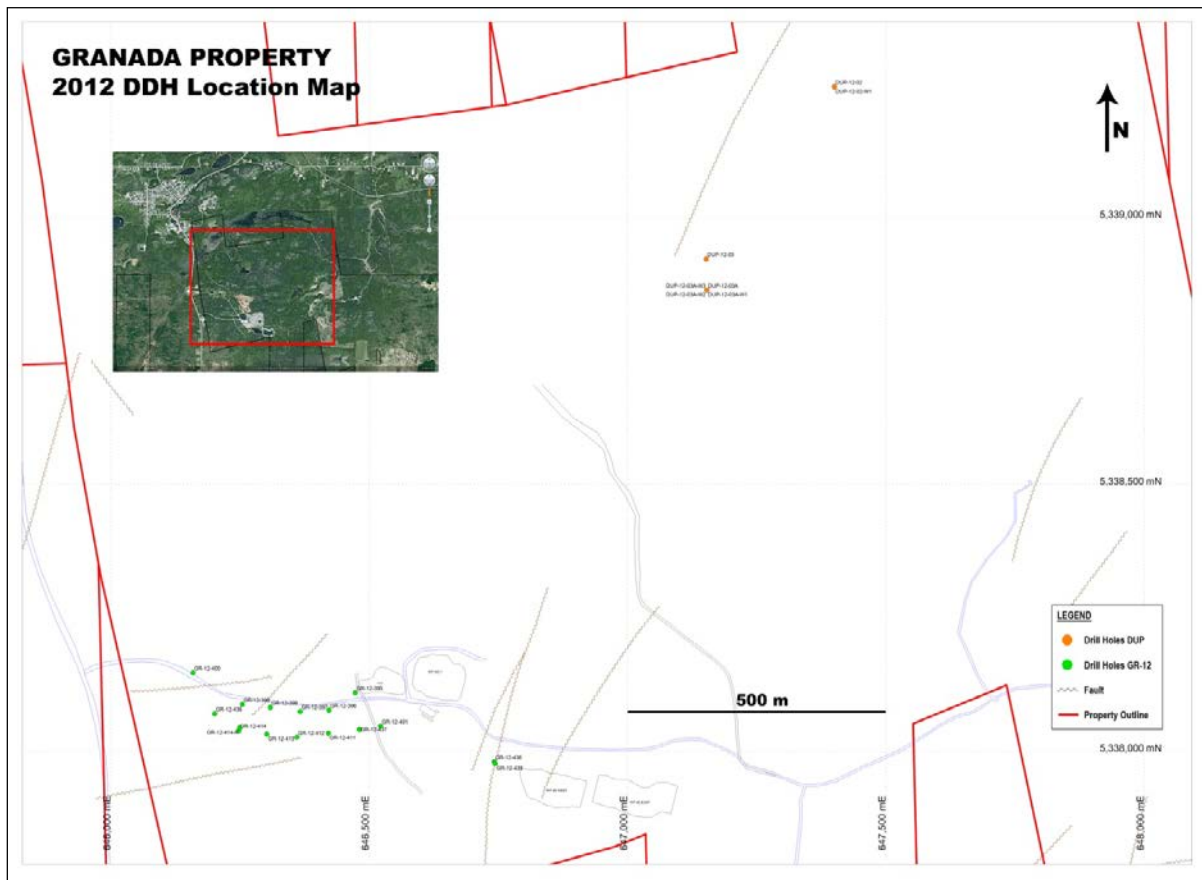

Figure 10-4: New 2012 Diamond Drillholes Location Map on Granada Property

A total of 8339.25 metres in 23 holes was drilled on the Granada Property. The drilling contractor was Landrill International Ltd. of Notre-Dame-Du-Nord, Quebec, which provided two surface diamond drill rigs (Marcotte Hydraulic model).

The drilling started on March 5, 2012 and concluded on July 6, 2012. All the drillholes were orientated south and drilled with different ranges of dip and length (see Table 10-2 and Table 10-3 for more details). Deep holes were spotted and surveyed by Mazac Geoservices Inc and the GR-12 holes were located by SGS Geologists using a handheld GPS. Down-hole orientation surveys were carried out by both Gyro and Reflex EZ-trac for the deep holes and only Reflex EZ-trac for the western extension holes.

Table 10-2: North Extension 2012 Drilling Program - Deep and Wedged Holes

Hole Name	Azimuth (°)	Dip (°)	From (m)	To (m)	Cumulative Length (m)	Core Size
DUP-12-02	181.0	-78.0	0.0	1593.00	1593.00	HQ-NQ
DUP-12-02-W1	181.0	-78.0	555.0	1263.20	708.20	HQ-NQ
DUP-12-03	180.0	-75.0	0.0	378.00	378.00	HQ-NQ
DUP-12-03A	175.9	-77.5	0.0	1350.00	1347.00	HQ-NQ
DUP-12-03A-W1	175.9	-77.5	780.0	1077.00	297.00	HQ-NQ
DUP-12-03A-W2	175.9	-77.5	597.0	1311.55	714.55	HQ-NQ
DUP-12-03A-W3	175.9	-77.5	632.0	1278.00	646.00	HQ-NQ
Total Meterage Drilled (m)					5683.75	

Table 10-3: West Extension 2012 Drilling Program

Hole Name	Azimuth (°)	Dip (°)	From (m)	To (m)	Cumulative Length (m)	Core Size
GR-12-395	183.8	-60.2	0.0	201.00	201.00	NQ
GR-12-396	186.5	-61.5	0.0	252.00	252.00	NQ
GR-12-397	193.5	-60.1	0.0	237.00	237.00	NQ
GR-12-398	188.6	-56.6	0.0	240.00	240.00	NQ
GR-12-399	189.6	-58.5	0.0	231.00	231.00	NQ
GR-12-400	183.2	-57.0	0.0	246.50	246.50	NQ
GR-12-401	190.0	-60.0	0.0	150.00	150.00	NQ
GR-12-411	190.0	-60.0	0.0	150.00	150.00	NQ
GR-12-412	190.0	-60.0	0.0	156.00	156.00	NQ
GR-12-413	190.0	-60.0	0.0	150.00	150.00	NQ
GR-12-414	190.0	-60.0	0.0	9.00	9.00	NQ
GR-12-414-R	189.5	-59.2	0.0	150.00	150.00	NQ
GR-12-436	193.0	-60.0	0.0	300.00	300.00	NQ
GR-12-437	190.0	-60.0	0.0	51.00	51.00	NQ
GR-12-438	190.0	-45.0	0.0	102.00	102.00	NQ
GR-12-439	190.0	-90.0	0.0	30.00	30.00	NQ
Total Meterage Drilled (m)					2655.50	

The following table (Table 10-4) contains the highlights of the mineralized intervals from the new drilling program and the backlog holes.

Table 10-4: Highlights of the 2012 DDH and the remaining Backlog Holes results

Drillhole Name	From (m)	To (m)	Length (m)	Au (g/t)
DUP-12-02	607.50	610.50	3.00	4.15
including	607.50	609.00	1.50	8.23
DUP-12-02	992.50	995.50	3.00	4.58
including	992.50	994.00	1.50	9.13
DUP-12-03A	660.00	662.50	2.50	1.38
including	661.00	662.50	1.50	3.21
DUP-12-03A	906.00	909.00	3.00	2.07
including	906.00	907.50	1.50	3.58
DUP-12-03A-W1	904.50	907.50	3.00	0.82
including	904.50	906.00	1.50	1.21
DUP-12-03A-W2	660.00	663.00	3.00	4.12
including	661.50	663.00	1.50	8.12
DUP-12-03A-W2	786.00	789.00	3.00	2.34
including	787.50	789.00	1.50	4.44
DUP-12-03A-W2	814.50	817.50	3.00	2.04
including	816.00	817.50	1.50	3.13
DUP-12-03A-W2	906.00	909.00	3.00	1.40
including	907.50	909.00	1.50	2.50
DUP-12-03A-W2	1218.00	1221.00	3.00	4.11
including	1218.00	1219.50	1.50	8.18
DUP-12-02-W1	784.50	787.50	3.00	4.19
including	784.50	786.00	1.50	8.26
E-11-01	NSI			
E-11-02	19.00	21.50	2.50	0.52
E-11-02	138.50	141.33	2.83	4.32
E-11-03	NSI			
E-11-04	NSI			
E-11-05	NSI			

Drillhole Name	From (m)	To (m)	Length (m)	Au (g/t)
E-11-06	NSI			
E-11-07	45.00	48.00	3.00	0.76
E-11-07	90.00	92.50	2.50	0.49
E-11-08	NSI			
E-11-09	NSI			
E-11-10	138	141.00	3.00	0.53
GR-11-241	283.00	289.00	6.00	2.25
GR-11-242	93.50	207.20	113.70	0.50
including	100.50	109.00	8.50	2.21
including	176.90	181.00	4.10	4.04
GR-11-246	243.00	283.50	40.50	0.47
GR-11-251	NSI			
GR-11-253	127.50	139.50	12.00	1.60
GR-11-254	NSI			
GR-11-257	165.50	211.50	46.00	2.25
including	189.50	211.50	22.00	4.42
including	312.00	323.50	11.50	0.41
GR-11-260	382.50	386.39	3.89	4.87
GR-11-261	23.50	31.75	8.25	0.52
GR-11-261	223.50	258.00	34.50	0.31
GR-11-262	NSI			
GR-11-263	NSI			
GR-11-264	347.00	353.00	6.00	3.31
GR-11-270	NSI			
GR-11-272	112.00	241.00	129.00	0.39
including	112.00	135.00	23.00	0.89
including	112.00	115.00	3.00	4.64
including	171.00	178.50	7.50	0.56
including	199.50	241.00	41.50	0.53
including	204.00	223.50	19.50	0.81
GR-11-274	58.00	63.50	5.50	0.54

Drillhole Name	From (m)	To (m)	Length (m)	Au (g/t)
GR-11-276	133.50	166.50	33.00	0.40
including	133.50	139.50	6.00	1.43
GR-11-282	NSI			
GR-11-285	13.25	30.70	17.45	0.88
GR-11-288	NSI			
GR-11-298	171.50	253.50	82.00	0.59
including	205.50	223.50	18.00	1.03
including	241.50	253.50	12.00	1.67
GR-11-298	336.00	339.50	3.50	4.01
GR-11-299	18.50	97.00	78.50	0.54
including	25.00	35.00	10.00	1.34
including	80.00	97.00	17.00	1.14
including	89.00	97.00	8.00	1.95
GR-11-300	16.50	84.50	68.00	0.70
including	16.50	28.50	12.00	0.89
including	68.50	84.50	16.00	1.98
GR-11-301	51.00	55.50	4.50	1.18
GR-11-302	16.00	126.50	110.50	0.48
including	16.00	83.50	67.50	0.68
including	30.00	53.50	23.50	1.11
including	46.00	53.50	7.50	2.47
including	75.50	83.50	8.00	1.26
GR-11-303	9.50	137.00	127.50	0.66
including	9.50	43.00	33.50	1.77
including	36.00	43.00	7.00	4.50
including	68.50	98.00	29.50	0.57
including	87.00	98.00	11.00	0.83
GR-11-304	177.00	217.50	40.50	0.45
including	177.00	181.50	4.50	0.73
including	213.00	217.50	4.50	2.97
GR-11-304A	229.50	345.00	115.50	0.34

Drillhole Name	From (m)	To (m)	Length (m)	Au (g/t)
including	229.50	240.00	10.50	0.60
including	290.00	300.00	10.00	1.30
including	316.50	326.00	9.50	0.64
GR-11-305	11.00	20.00	9.00	0.52
including	10.00	13.00	3.00	1.18
GR-11-305	70.50	82.00	11.50	0.58
GR-11-306	11.00	20.00	9.00	0.52
GR-11-306	70.50	82.00	11.50	0.58
including	76.50	82.00	5.50	0.60
GR-11-307	61.00	79.50	18.50	0.36
including	62.00	67.00	5.00	1.01
GR-11-308	29.00	90.00	61.00	0.34
including	29.00	33.50	4.50	3.11
GR-11-309	12.50	91.50	79.00	0.89
including	55.00	91.50	36.50	1.71
including	60.50	85.00	24.50	2.26
including	60.50	71.50	11.00	3.87
including	77.00	85.00	8.00	1.54
GR-11-309	154.50	165.00	10.50	0.82
GR-11-310	15.00	44.23	29.23	15.61
including	21.00	26.00	5.00	88.97
including	22.00	23.00	1.00	443.78
GR-11-311	54.50	86.50	32.00	2.49
including	65.50	73.00	7.50	9.44
including	157.00	180.50	23.50	0.74
including	157.00	169.00	12.00	1.17
GR-11-312	27.58	38.50	10.92	0.70
Including	27.58	30.50	2.92	1.65
GR-11-312	84.00	87.00	3.00	1.50
GR-11-313	3.30	51.95	48.65	0.37
including	3.30	10.00	6.70	1.80

Drillhole Name	From (m)	To (m)	Length (m)	Au (g/t)
GR-11-313	106.00	117.50	11.50	0.45
GR-11-313	117.50	132.50	15.00	0.48
GR-11-314	3.30	78.00	74.70	0.41
including	61.00	78.00	17.00	1.10
including	61.00	65.50	4.50	2.12
and	25.50	29.50	4.00	0.74
GR-11-315	66.50	109.50	43.00	0.32
including	76.00	109.50	33.50	0.36
including	76.00	89.00	13.00	0.55
and	102.00	109.50	7.50	0.52
GR-11-316	105.50	150.00	44.50	0.37
including	105.50	122.00	16.50	0.68
including	113.00	122.00	9.00	1.01
GR-11-317	NSI			
GR-11-318	NSI			
GR-11-319	76.00	79.00	3.00	0.48
GR-11-320	12.00	84.00	72.00	0.46
including	32.00	44.50	12.50	1.84
GR-11-321	94.50	101.00	6.50	0.97
including	94.50	97.50	3.00	1.63
GR-11-322	24.50	33.00	8.50	0.46
GR-11-322	79.50	85.50	6.00	0.67
GR-11-323	NSI			
GR-11-324	25.00	40.00	15.00	0.66
including	34.50	39.00	4.50	1.74
GR-11-325	NSI			
GR-11-326	4.50	93.50	89.00	0.65
including	4.50	22.00	17.50	2.78
including	11.40	15.50	4.10	11.16
GR-11-324	95.85	99.00	3.15	0.70
GR-11-328	12.50	47.00	34.50	0.78

Drillhole Name	From (m)	To (m)	Length (m)	Au (g/t)
including	31.50	47.00	15.50	1.59
including	71.50	118.50	47.00	0.44
including	114.50	118.50	4.00	3.20
GR-11-329	16.50	19.50	3.00	1.21
GR-11-329	45.90	48.00	2.10	1.08
GR-11-330	60.96	68.80	7.84	7.93
Including	60.96	64.00	3.04	19.23
GR-11-330	99.00	112.00	13.00	5.63
Including	99.00	102.00	3.00	22.35
Including	109.00	112.00	3.00	1.88
GR-11-331	71.08	82.50	11.42	0.50
GR-11-331	129.00	132.00	3.00	1.41
GR-11-332	NSI			
GR-11-333	NSI			
GR-11-334	75.50	80.50	5.00	0.88
including	105.50	121.50	16.00	0.50
GR-11-335	24.00	138.00	114.00	0.71
Including	39.50	42.00	2.50	2.95
Including	99.40	103.00	3.60	5.01
Including	131.00	138.00	7.00	5.73
GR-11-336	21.00	81.50	60.40	0.50
Including	77.00	81.50	4.50	3.50
GR-11-337	9.00	64.00	55.00	0.33
Including	59.50	64.00	4.50	2.30
GR-11-337	131.50	134.50	3.00	2.64
GR-11-338	6.00	56.00	50.00	0.47
Including	21.00	25.50	4.50	2.42
Including	43.50	48.00	4.50	1.18
GR-11-339	6.00	29.00	23.00	0.56
Including	23.50	26.50	3.00	3.20
GR-11-340	6.50	142.00	135.50	0.29

Drillhole Name	From (m)	To (m)	Length (m)	Au (g/t)
Including	6.50	14.00	7.50	0.53
Including	111.00	142.00	31.00	0.77
Including	124.00	128.50	4.50	2.12
GR-11-341	205.50	235.50	30.00	0.44
including	205.50	211.50	6.00	1.21
including	205.50	216.00	10.50	1.01
GR-11-342	66.00	69.36	3.36	1.19
GR-11-343	222.00	225.00	3.00	1.68
GR-11-344	19.50	30.00	10.50	1.27
Including	22.50	27.00	4.50	2.64
GR-11-345	91.50	140.00	48.50	0.50
including	91.50	96.00	4.50	2.77
GR-11-345	227.50	243.00	15.50	0.45
GR-11-345	333.50	336.50	3.00	4.45
GR-11-346	13.50	53.00	39.50	0.26
Including	50.50	53.00	2.50	1.98
GR-11-347	16.00	63.00	47.00	0.36
Including	50.00	63.00	13.00	0.82
Including	60.00	63.00	3.00	2.47
GR-11-348	41.00	52.50	11.50	0.39
GR-11-349	82.50	89.00	6.50	2.74
GR-11-350	16.50	114.00	97.50	0.86
GR-11-350	16.50	21.00	4.50	15.72
and	207.50	300.00	92.50	0.56
including	236.00	239.00	3.00	9.62
including	297.00	300.00	3.00	2.97
GR-11-351	161.00	173.00	12.00	0.43
GR-11-352	18.50	24.00	5.50	0.60
GR-11-352	100.50	103.50	3.00	5.04
GR-11-354	158.50	350.05	191.55	0.54
Including	171.00	176.00	5.00	6.08

Drillhole Name	From (m)	To (m)	Length (m)	Au (g/t)
Including	204.00	208.50	4.50	3.65
Including	244.30	247.60	3.30	1.86
Including	301.00	303.70	2.70	2.65
Including	318.50	321.50	3.00	3.87
Including	341.00	344.00	3.00	2.12
GR-11-355	23.50	31.47	7.97	0.82
GR-11-355	90.10	123.50	33.40	0.56
including	114.00	122.00	8.00	1.75
GR-11-356	6.00	51.00	45.00	0.31
including	6.00	15.50	9.50	0.54
including	34.60	51.00	16.40	0.40
GR-11-356	102.00	111.20	9.20	0.59
GR-11-357	110.00	125.50	15.50	0.74
including	119.30	122.50	3.20	2.44
GR-11-358	4.50	15.00	10.50	0.53
GR-11-358	149.00	339.65	190.65	0.39
including	149.00	170.00	21.00	1.19
including	149.00	150.50	1.50	6.38
including	165.50	167.00	1.50	3.86
including	237.00	246.00	9.00	0.86
including	271.50	279.00	7.50	2.61
including	328.00	339.65	11.65	0.80
GR-11-359	159.00	165.00	6.00	1.02
GR-11-360	93.00	96.00	3.00	2.88
GR-11-360	122.00	125.00	3.00	0.85
GR-11-361	82.50	153.50	71.00	0.55
including	84.00	102.50	18.50	0.93
including	82.50	87.00	4.50	2.74
including	99.50	102.50	3.00	1.29
including	150.50	153.50	3.00	5.29
GR-11-362	56.00	61.50	5.50	1.40

Drillhole Name	From (m)	To (m)	Length (m)	Au (g/t)
GR-11-362	143.00	201.00	58.00	1.76
including	143.00	149.00	6.00	15.27
GR-11-363	23.50	82.50	59.00	0.43
GR-11-364	NSI			
GR-11-365	54.50	73.00	18.50	0.63
including	54.50	66.00	11.50	0.91
GR-11-365	140.00	154.00	14.00	0.54
GR-11-366	45.00	58.50	13.50	0.34
GR-11-366	144.50	223.50	79.00	0.58
including	155.50	180.00	24.50	0.81
including	168.00	180.00	12.00	1.28
GR-11-366	193.00	213.00	20.00	0.95
including	202.00	213.00	11.00	1.34
GR-11-367	155.10	159.00	3.90	0.91
GR-11-368	184.00	205.15	21.15	1.72
including	201.00	205.15	4.15	7.89
GR-11-369	156.00	211.00	55.00	0.41
including	156.00	179.00	23.00	0.72
including	157.00	167.00	10.00	1.19
GR-11-370	139.00	163.50	24.50	0.57
GR-11-371	53.00	60.00	7.00	0.39
GR-11-373	272.50	320.60	48.10	0.47
including	272.50	278.00	5.50	1.71
including	314.00	319.20	5.20	1.70
GR-11-374	192.00	216.00	24.00	1.14
including	199.50	205.15	5.65	4.08
GR-11-372	116.50	182.00	65.50	0.28
including	116.50	120.50	4.00	1.34
including	142.50	145.50	3.00	1.94
including	181.00	185.00	4.00	0.83
GR-11-375	10.50	120.30	109.80	0.32

Drillhole Name	From (m)	To (m)	Length (m)	Au (g/t)
including	117.00	120.30	3.30	7.22
GR-11-375	173.50	177.00	3.50	0.98
GR-11-376	275.00	395.00	12.00	0.39
GR-11-377	261.00	349.50	88.50	0.62
including	261.00	267.00	6.00	1.79
including	325.00	331.50	6.50	3.56
including	345.00	349.50	4.50	1.05
GR-11-377	427.50	431.00	3.50	3.72
GR-11-378	29.00	78.00	49.00	0.47
including	22.50	29.50	7.00	1.75
including	75.00	78.00	3.00	2.20
GR-11-379	10.50	15.85	5.35	0.90
GR-11-380	8.00	58.00	50.00	0.63
including	10.00	13.50	3.50	6.95
including	54.50	58.00	3.50	1.11
GR-11-381	13.00	23.00	10.00	4.68
including	16.50	19.45	2.95	15.13
GR-11-383	25.50	33.00	7.50	0.67
GR-11-384	422.50	428.50	6.00	18.25
including	309.00	351.00	42.00	0.44
GR-11-385	64.50	73.50	9.00	0.81
GR-11-386	24.00	61.50	37.50	0.45
including	48.00	61.50	13.50	1.14
including	58.50	61.50	3.00	2.49
GR-11-387	22.50	32.50	10.00	0.31
GR-11-388	66.00	73.50	7.50	0.77
GR-11-389	72.00	167.00	95.00	0.53
including	120.00	148.00	28.00	1.21
including	136.00	148.00	12.00	2.38
including	142.00	148.00	6.00	4.39
GR-11-391	39.00	174.00	135.00	0.26

Drillhole Name	From (m)	To (m)	Length (m)	Au (g/t)
including	39.00	48.50	9.50	0.99
including	104.00	107.00	3.00	1.48
including	171.00	174.00	3.00	2.28
GR-11-392	343.50	346.50	3.00	2.19
GR-11-393	164.50	465.50	301.00	0.31
including	164.50	167.50	3.00	2.52
including	273.50	278.00	4.50	2.10
including	296.00	299.50	3.50	2.05
including	318.00	321.80	3.80	2.81
including	427.50	433.00	5.50	3.62
GR-11-394	302.50	319.50	17.00	1.23
including	302.50	307.00	4.50	3.28
GR-11-394	516.00	519.00	3.00	2.58
GR-12-395	72.00	85.50	13.50	0.64
GR-12-396	49.50	63.00	13.50	0.64
GR-12-397	34.00	42.00	8.00	0.53
GR-12-398	52.50	60.00	7.50	0.58
GR-12-399	129.00	138.00	9.00	0.83
GR-12-399	36.00	45.00	9.00	0.45
GR-12-400	30.00	115.50	85.50	0.45
including	30.00	31.50	1.50	6.39
including	61.50	64.50	3.00	3.41
including	114.00	115.50	1.50	2.49
GR-12-401	93.00	100.50	7.50	0.82
GR-12-412	15.00	97.50	82.50	0.58
including	15.00	19.50	4.50	8.39
including	94.50	97.50	3.00	1.46
GR-12-413	4.50	114.00	109.50	0.55
including	4.50	7.50	3.00	11.54
including	81.00	82.50	1.50	1.07
including	93.00	94.50	1.50	4.40

Drillhole Name	From (m)	To (m)	Length (m)	Au (g/t)
including	112.50	114.00	1.50	2.50
GR-12-414-R	7.50	36.00	28.50	0.92
including	7.50	9.00	1.50	1.75
including	12.00	15.00	3.00	3.26
including	16.50	19.50	3.00	1.69
including	28.50	36.00	7.50	0.94
GR-12-436	37.50	42.00	4.50	1.62
GR-12-436	264.00	267.00	3.00	4.01
GR-12-437	48.00	51.00	3.00	1.34
GR-12-438	10.00	12.00	2.00	0.57
GR-12-438	57.00	60.00	3.00	0.80
GR-12-438	85.50	88.50	3.00	1.17
GR-12-439	18.00	24.00	6.00	0.83

This drill results confirm specific high grade zones at depth with thickness and grade suitable for underground mining. Down hole core length is close to true thickness and uncut.

10.4 CORE RECOVERY

In this project, the core recovery is about 99% with some losses generally occurring in the beginning of the hole and also near shears or faults zones. Rock Quality Designation (RQD) measurements indicate that the rocks units observed in the Granada property are very competent.

11 Sample Preparation, Analyses and Security

11.1 CONTEXT

The previous consultant responsible of the drilling campaign management and execution did not prepare a formal report on the subject from 2009 to 2011. This section will present what the author has been able to discover on the subject. From the beginning of author's involvement in the project it was clear that not all information would be retrieved. This initiated an extensive independent sampling program, the details of which are available in the data verification section of this report.

11.2 DRILL CORE SAMPLING PROTOCOL

During the 2009 to 2011 drill campaign, samples of NQ size core were systematically assayed for gold and occasionally for arsenic and silver with multi-element packages.

All core samples assays from the exploration programs were performed by 4 various laboratories:

- Lab-Expert in 2009-2010
- Swastika in 2010
- ALS-Chemex in 2010-2011
- Accurassay in 2010-2011

These laboratories have facilities in Quebec, Ontario and BC: Rouyn, Swastika, Val D'Or and Vancouver. The sampling procedures included the systematic inclusion of standards and property specific blank samples. The drillhole core samples were split in half with a rock saw. One half was sent for assaying while the second half was retained as a witness sample for future geological reference or for re-assaying should it be deemed necessary. Sampling was conducted not only on core with visible evidence of mineralization such as: veins, stringers, and alteration zones, but also on barren looking core to preserve the sampling continuity between mineralized zones and to test for broad zones of lower grade material.

The core sampling protocol used by the previous consultants is presumed as follows:

- The core is logged by geologist.
- For mineralized intervals of NQ sized core, the drill core samples have a minimum sample length of 30 cm and a maximum length of 1.5 m.
- Photos of the main mineralized intersections are taken using a digital camera.
- Core is split in half with a rock saw by GBB technicians at the project site.
- Half core samples are retained for future references and are returned to the core box along with their respective serialized assay tag.
- Samples are bagged at the project site and delivered by commercial courier to the lab facilities.
- The sampling procedure includes the insertion of commercially prepared standards and property specific blanks collected from similar geological units, at regular intervals.
- (Key information table to retrieve this information was not found).

The information recorded in the drill log by the project geologist describing the core normally includes: the from-to, depth, core length, true width, as well as observations concerning rock type, deformation, alteration, fault zones and nature of mineralization, the name of the vein if possible, and core angles. All observations are normally entered into drillhole database management software.

All core boxes are stored outside on site. Each individual core box is identified with aluminum tags labelled by a Dymo® label writer including the drillhole number. The boxes are stored on core racks. The site has

constant security surveillance. Due to the large number of relevant samples included in the resource estimate the remaining core intersections and composites have not been tabulated in this section or in this report.



Figure 11-1: Permanent core racks and mobile core racks

From the picture in Figure 11-1 it can be seen that core has not been cut and the entire core is in the mobile racks.

11.3 CHANNEL SAMPLING PROTOCOL

During the 2013 channel sampling campaign, core samples were systematically assayed for gold with multi-element package by Accurassay laboratory in Rouyn Noranda. The sampling procedure included insertion of standards and blanks. The channel samples were made with a mechanical saw and sectioned in 1 metre long samples. Samples were identified, packaged and sent to Accurassay lab. Each sample was surveyed by a surveyor (location of “from” and “to”).

- The trench locations were identified by the geologist.
- The trenches were dug by a shovel operator.
- The bedrock was cleaned using water hoses.
- The channels were set by technician and sectioned into metres.
- Photos of the channel were taken using a digital camera.
- Rock samples were cut using a rock saw.
- Samples were bagged at the project site and delivered directly to the lab facilities by the technician.
- The sampling procedure included the insertion of commercially prepared standards and property specific blanks collected from similar geological units, at regular intervals.

11.4 ANALYSES

Sample preparation and assaying procedures for 2009 through 2011 have changed.

As we understand there was one standard procedure for regular samples however when visible gold was observed in core a secondary procedure was adopted which include a complete pulp metallic (screen metallic) assay on the whole sample.

Sample preparation includes the following procedures and operations; however they may not have been performed on all samples but for the majority of them:

- Log sample into the tracking system.
- Record the weight of material received from the client.
- Crush drill core samples to finer than 70% passing 2 mm.
- Split sample using a riffle splitter.
- Pulverize the split (up to 250 g) to a particle size finer than 85% passing 75 µm.

Once the sample is pulverized the following assay methods are then applied to the sample:

- Gold assays are routinely performed using fire assay (FA) with atomic absorption (AA) finish. High gold assays are automatically re-assayed using a FA with gravimetric finish.
- A multi-element geochemical package was used to determine As, Ag and others elemental concentrations.

In the context the author and team have focused all its work on retrieving the gold data.

11.5 QUALITY ASSURANCE/QUALITY CONTROL (QA/QC) PROGRAM

The previous consultant for GBB had implemented a Quality Assurance/Quality Control (QA/QC) program for the Granada project at the beginning of the 2009 to 2011 drill program.

It was found that it was consisting of the insertion of commercially prepared reference material.

The exact structure (list-computerized table) for the insertion of standards and blanks into the sampling sequence is not available. Regardless, the physical sample tags with: drillhole numbers, from-to depths, and unique sample number referring to the from-to depths that were used to rebuild the database independently of the QA/QC assay, they were put aside.

This being said it was possible to build a table to check QA/QC from the ALS–Chemex laboratory's internal blanks and standards data. The following table confirms there was apparently no failure in terms of contamination at the ALS laboratory.

Not having the target value it is difficult to judge, however we can observe that the SF 30 was likely two different reference materials and that OXL 78 standard had one failure. The source samples and the follow-up actions are unknown regarding this batch.

Table 11-1: Statistics ALS internal lab blanks

Laboratory Blanks Statistics Au ppm	
Mean	0.006
Standard Error	0.0002
Median	0.005
Mode	0.005
Standard Deviation	0.002
Sample Variance	0.000004
Minimum	0.005
Maximum	0.010
Count	156

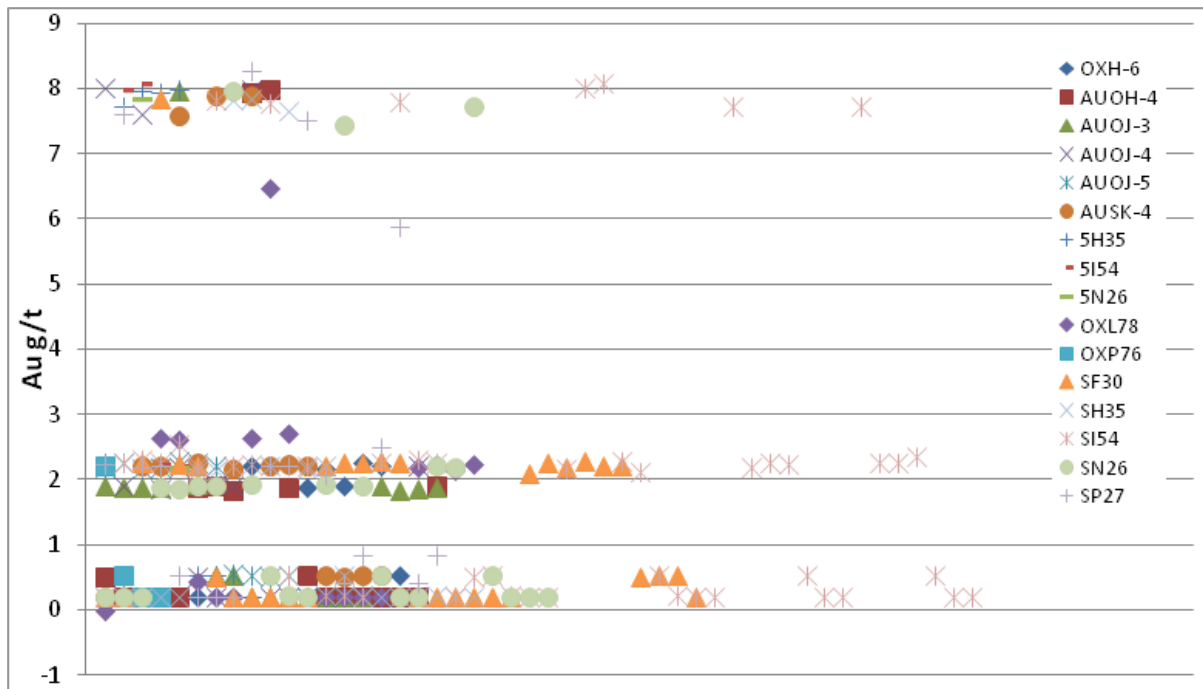

Figure 11-2: Graphic of ALS internal lab standard variation from 1456 data

We are aware that field duplicate samples may have been submitted to the assay laboratories during the drilling program.

11.6 SECURITY

If we put aside that there has been a security failure at site when the previous consultant took off site critical project data during a weekend in autumn 2011. The author is of opinion that a chain of custody was probably in place prior to occurrence of problems between the service provider and the company.

In the author's opinion the sample preparation was adequate as far as we have been able to verify with the laboratories, however it appears to have changed over time to accommodate bigger amount of rock crushed and pulverized prior to splitting, which is good. As for security there is no reason to believe that tampering has occurred as per arguments of the next section and the physical observation of gold in core at the site. The gold fire assay and screen metallic are industry standard for analysis of gold and are acceptable.

The reader should keep in mind that this property is not a green field and mining activities have taken place and previous owners had demonstrated the presence of gold in the ground.

An extensive independent sampling program has been put in place right at the beginning of the mandate in order to compensate the lack of follow-up on previous QA/QC, which also built confidence on the data for preparation of the resource estimate in the context of a nuggety gold project.

11.7 QAQC PROGRAM 2012

Gold Bullion Development Corp adhered to a quality control procedure, including inserting standards, blanks and duplicate samples. This section represents a comment of the QAQC data available to the author at the moment of the update resource estimation.

11.7.1 ANALYTICAL STANDARDS

One (1) sample out of every 26 is an established standard purchased from either Ore Research, Exploration or from Accurassay and inserted by SGS Geostat. The inserted standard is one of the standards listed in the following table. The standards were inserted in a predefined sequence, as standard 15d and 2Pd were exhausted they were replaced by HGS1 and HGS3 respectively in the quality control sequence.

Table 11-2: Reference Material for Granada Project

standard	Mean [Au (g/t)]	1 std. Dev.	Performance Gate					
			1σ		2σ		3σ	
			Low	High	Low	High	Low	High
OREAS 15d	1.56	0.042	1.518	1.602	1.476	1.644	1.434	1.686
OREAS 15f	0.334	0.016	0.318	0.35	0.302	0.366	0.286	0.382
OREAS 15h	1.02	0.025	0.995	1.045	0.97	1.07	0.945	1.095
OREAS 6Pc	1.52	0.065	1.455	1.585	1.39	1.65	1.325	1.715
OREAS 2Pd	0.885	0.030	0.855	0.915	0.825	0.945	0.795	0.975
HGS1	2.784	0.225	2.559	3.009	2.334	3.234	2.109	3.459
HGS3	4.009	0.250	3.759	4.259	3.509	4.509	3.259	4.759

Each of the seven standards were sorted by hole number, and plotted on graphs (Figure 11-3, Figure 11-4, Figure 11-5, Figure 11-6, Figure 11-7, Figure 11-8, Figure 11-9) with their performance gates (and measured and expected mean values). A sign test was conducted for each standard to measure if there was bias; a summary of the sign test is in (Table 10-4). None of the standards indicated serious bias based on the results of the sign test, the only standard to fail the sign test was the OREAS 15f standard

which was slightly biased high. This bias can in part be explained by 2 anonymously high values and another high value that appears to be a mislabelled standard. Even though there is a slight bias high, OREAS 15f has the lowest absolute and relative amount of QC failures and almost all the data falls between the mean and 2nd standard deviation. The results of the data for the standards indicate that control has been established and there is no significant bias.

Table 11-3: Summary of Analytical Results for Au in Reference Materials

Reference Material	Total N	Expected Au (g/t)		Observed Au (g/t)		% of Exp	Mislabeled	Failures ($\pm 3\sigma$)
		Average	Std.Dev	Average	Std.Dev			
OREAS 15d	99	1.56	0.04	1.59	0.94	101.70%	1	13
OREAS 15f	102	0.334	0.02	0.34	0.05	102.70%	0	3
OREAS 15h	106	1.02	0.03	0.99	0.16	96.90%	2	17
OREAS 2Pd	96	0.885	0.03	0.87	0.22	98.50%	2	8
OREAS 6Pc	145	1.52	0.07	1.5	0.14	98.90%	0	15
HGS1	57	2.784	0.23	2.81	0.65	101.00%	1	8
HGS3	61	4.009	0.25	3.86	0.76	96.20%	3	4
TOTAL	666	*Weighted Average				99.50%	9	68

Table 11-4: Sign Test Results for Reference Materials.

Reference Material	Total N	Sign Test Gates		n (*)	n/N	Bias
		Min	Max			
OREAS 15d	99	0.40	0.60	46	0.46	FALSE
OREAS 15f	102	0.40	0.60	64	0.63	TRUE
OREAS 15h	106	0.40	0.60	54	0.50	FALSE
OREAS 2Pd	96	0.40	0.60	44	0.45	FALSE
OREAS 6Pc	145	0.42	0.58	74	0.51	FALSE
HGS1	57	0.37	0.63	29	0.51	FALSE
HGS3	61	0.37	0.63	25	0.41	FALSE
TOTAL	666	* the number of measured values greater than expected				

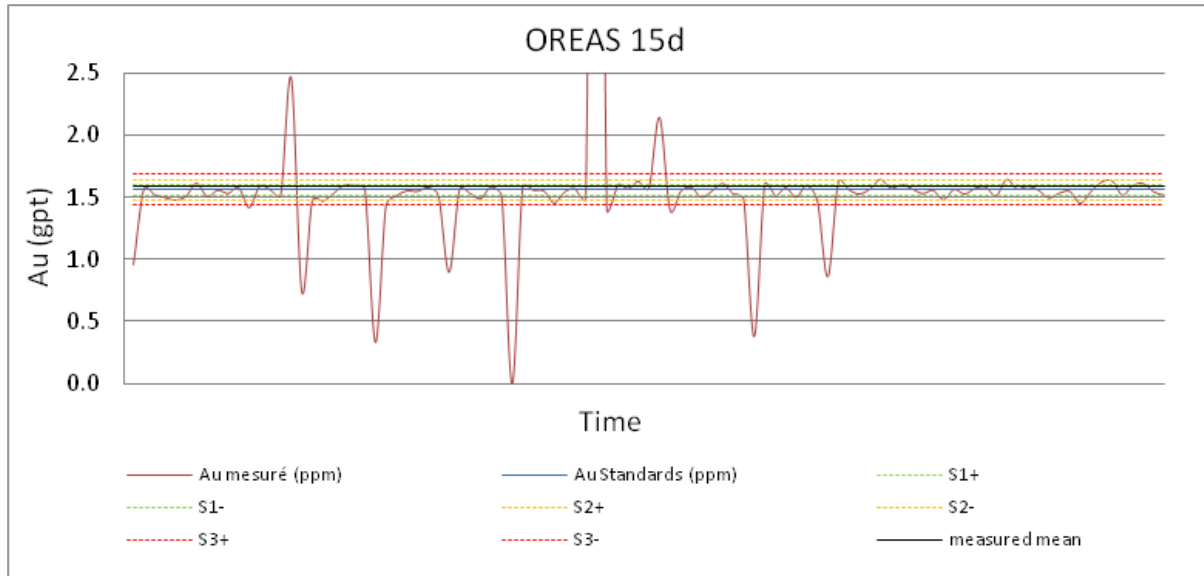

Figure 11-3: Standard OREAS 15d Results for Au

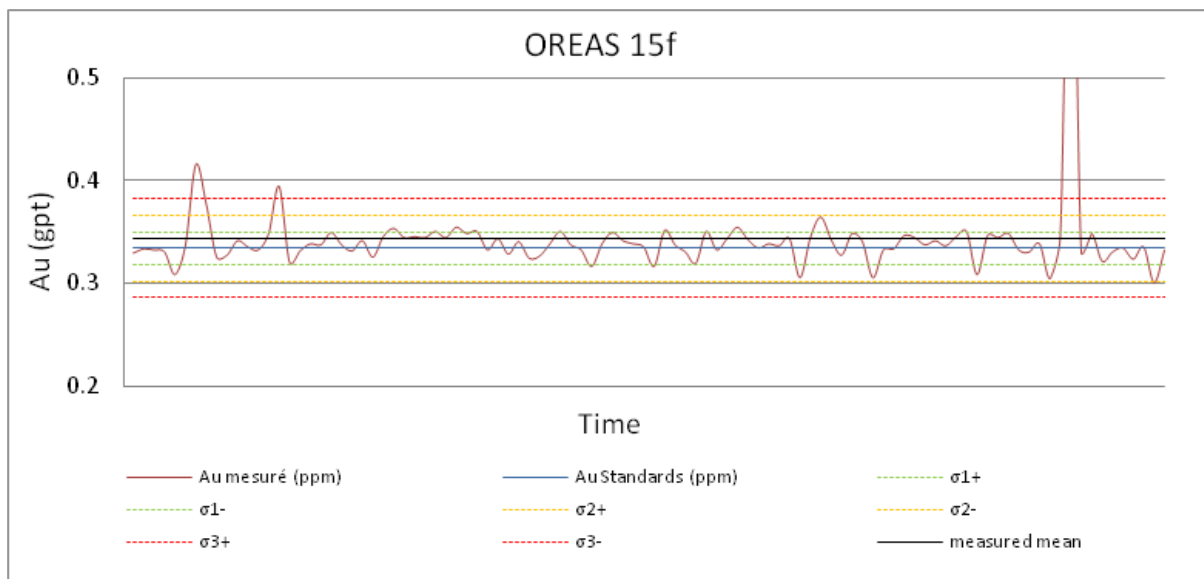

Figure 11-4: Standard OREAS 15f Results for Au

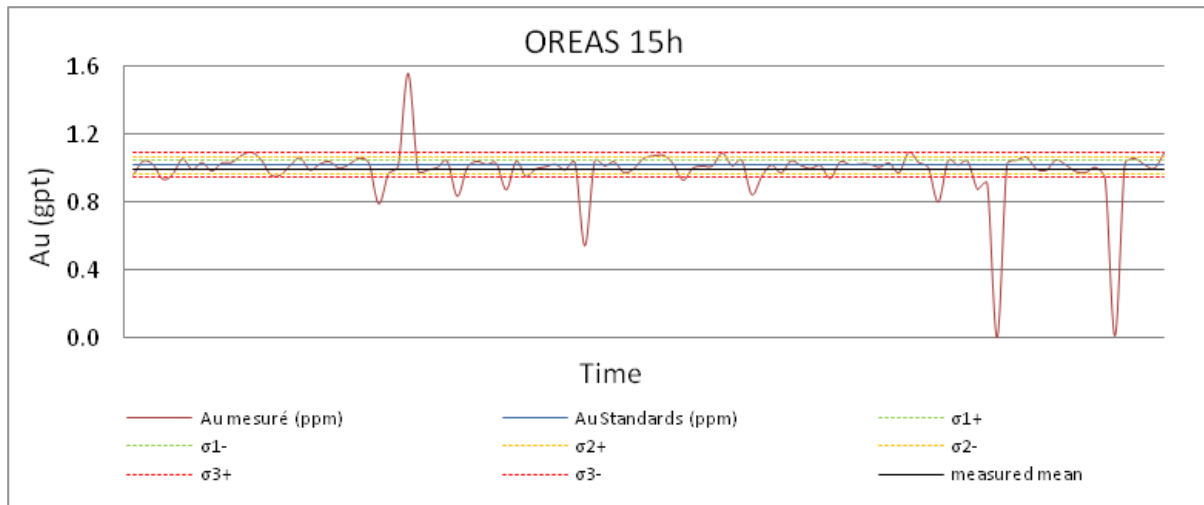

Figure 11-5: Standard OREAS 15h Results for Au

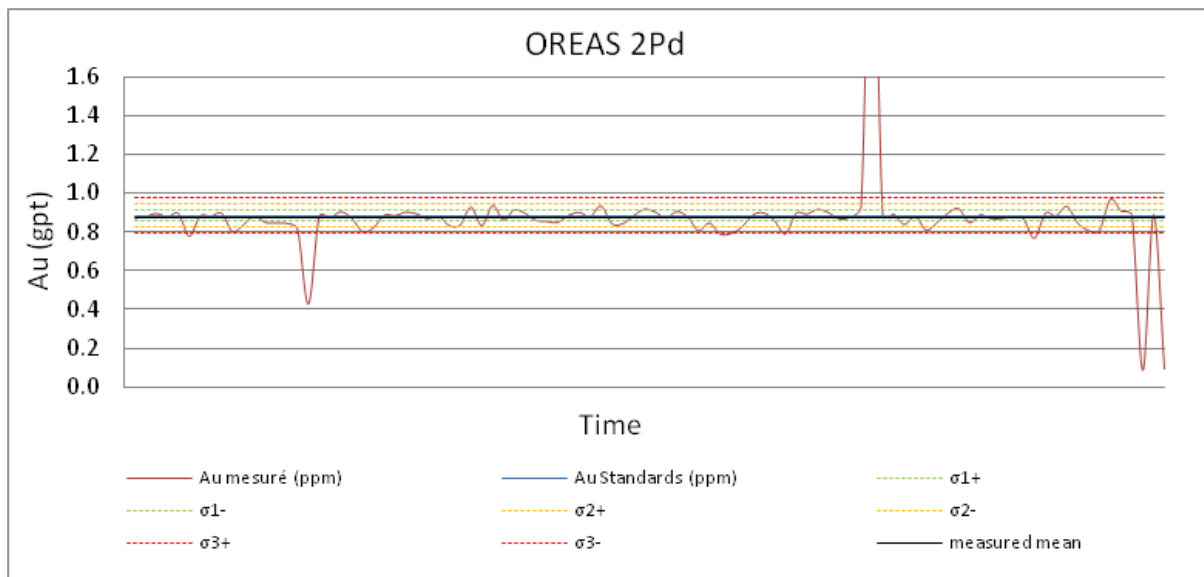

Figure 11-6: Standard OREAS 2Pd Results for Au

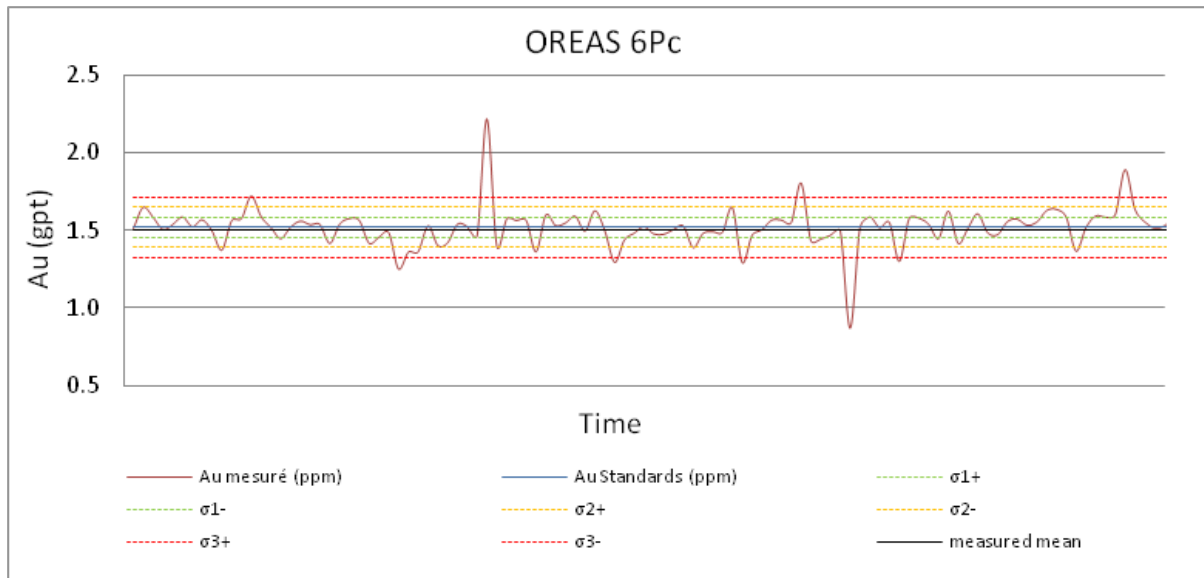

Figure 11-7: Standard OREAS 6Pc Results for Au

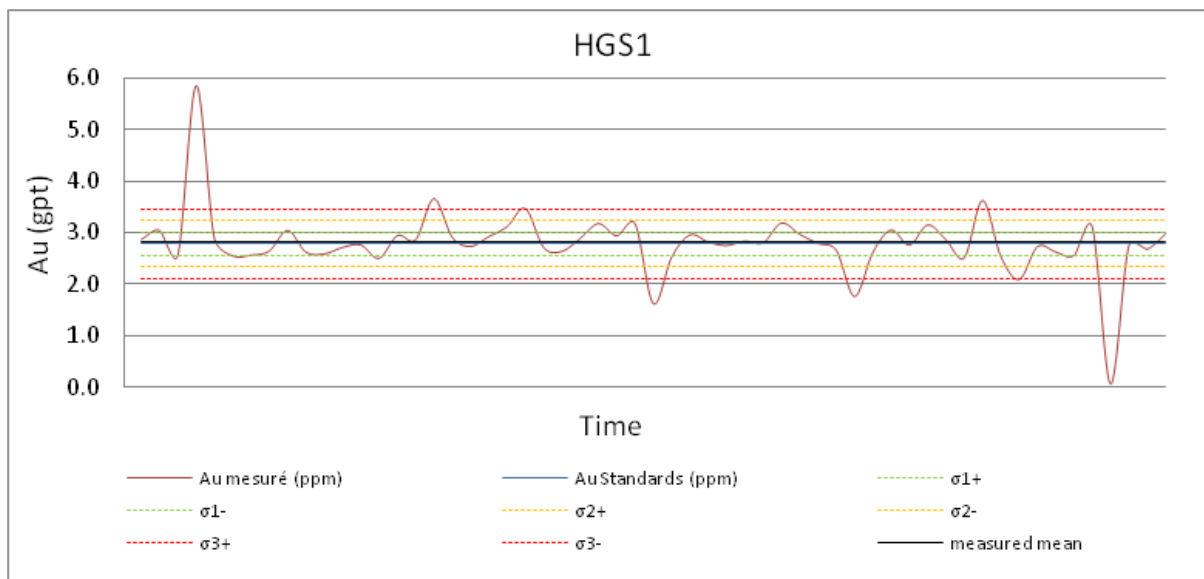

Figure 11-8: Standard Accurassay HGS1 Results for Au

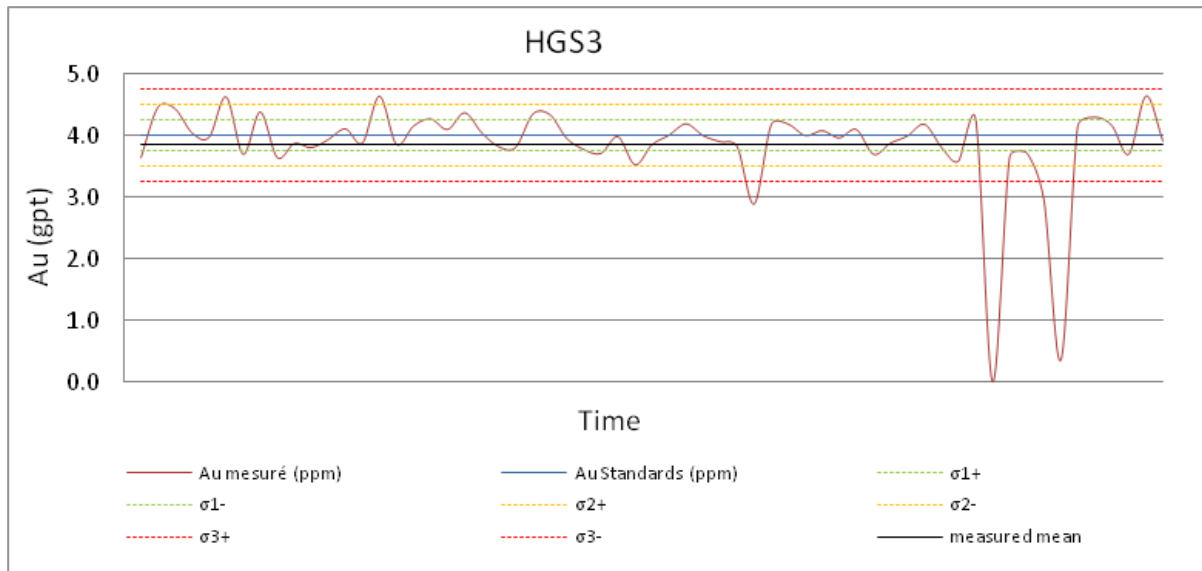

Figure 11-9: Standard Accurassay HGS3 Results for Au

Three (3) standards (samples 1332010, 1292428, and 1373653) were removed from the population due to sequence errors in the laboratory, this was determined when they all came back low, and upon review of the results it was determined that there was a sequence error at the laboratory. These samples were removed from the statistical population; however the results were not removed from the block model. These three (3) errors will not have significant effect on the block model; through inspection of the results in the sample batches these errors have no effect on mineralized intervals.

Samples 1345376, 1293029, 1373310, 1132923 were removed from the statistics population because there was insufficient material for assay.

Samples 1333037, 1293057, 1294437, 1295253, 1295513, 1295985, 1301012, 1301409, 1301528 have been identified as mislabels and with supporting evidence have been changed before final QAQC analysis. Other samples that are suspected to be mislabels have been left in the population due to a lack of proof to relabel the samples.

Standards that had very high percent difference from the mean value were investigated on an individual basis. The results of this investigation are summarized;

From work order 1155-201250303, sample 1294929 identified as a STD 15h had a Au value failure, however the geochemical signature matched other 15h standards for non gold responses. Based on the other results of the work order, the failure should not affect the block-model and control is re-established by surrounding control sample.

From work order 1155-201250388, sample 1295961 identified as a STD 15h had a Au value failure, the subsequent sample had a Au value of 7.314 g/t. The following sample is not likely a mislabel, there is the possibility of having a bias low and effect could be underestimating the gold value.

From work order 1155-201250402, sample 1332010 identified as a STD 15h had a Au value failure. It appears there is a sequence error at the laboratory and that sample 1332009 is indeed the standard, the sequence error is contained within the previous and next control samples, the possible effect upgrading the deposit but not significantly.

From work order 1155-201250249, sample 1292428 identified as a STD 15h had a Au value failure. After investigating it appears to be a sequence error at the laboratory, the error is contained within the last and

next control samples, and it is likely sample 1292429 should be the STD15h through matching the geochemical signature, and the sample 1292428 more closely matches the signature of the deposit. The effect is a possible upgrading of the deposit, though the error has been realized the model has not been changed since the resulting effect is close to negligible.

From work order 1155-201250408, sample 1300356 identified as a STD 2Pd had a Au value failure. It appears to be an unknown failure; no other irregularities appear in the sample sequence, geochemical values for all other reported elements appear normal. Although there is potential to cause a bias low in gold results, the range of their error is unlikely to affect the overall database.

From work order 1155-201250414, sample 1300536 identified as a STD 2Pd had a Au value failure. There are no apparent discrepancies, and geochemistry matches standard for all other recorded elements. Due to the range of control loss, this should have insignificant contribution to the model.

From work order 1155-201250384, sample 1378309 identified as a STD HGS1 had a Au Value failure. No other apparent errors in surrounding analytical sequence. There is potential to cause a bias low in gold results, however no potential to produce significant bias in the block model.

From work order 1155-201250248, sample 1293453 identified as a STD HGS1 had a Au Value spike. The result has potential to cause a bias high in the database, however no samples of significance are affected in the surrounding sequence, there is insignificant impact on database before control is re-established.

From work order 1155-201250377, sample 1332957 identified as a STD HGS3 had a Au value failure. There is potential to cause a bias low for gold result, however there are no values of significance in the sequence before control is re-established.

From work order 1155-201250342, sample 1261352 identified as a STD 15d had a Au value failure. There is potential to cause a bias low for gold result, however there are no values of significance in the sequence before control is re-established.

From work order 1155-201250123, sample 1373653 identified as a STD 15d had a Au value failure. Through investigation it is determined the most likely a sequence error occurred in the lab, and the probable value for STD15d is sample 1343652. Control is re-established by the previous and next control samples, this should not create major bias in data. Even though we are aware of a potential sequence error, the model has not been recalculated and the bias will not be of significance.

From work order 1155-201250290, sample 1333133 identified as a STD 15d had an Au value spike. The geochemical signature is consistent with other STD 15d's for elements other than gold. This result could indicate that there is a bias high in the batch sequence results, however no samples of interest are present in the following sequence and effect on the database is minimal.

It is a possibility that unknown spikes and failures of gold values in standards could be caused by unintentional shaking of standards and creating a nugget effect through gravity separation.

11.7.2 ANALYTICAL BLANKS

Six (6) of every 200 samples were sent to the laboratory as blank material. The material is a marble purchased from the local hardware store and inserted by SGS Geostat. A total of 340 blanks are in the assay database.

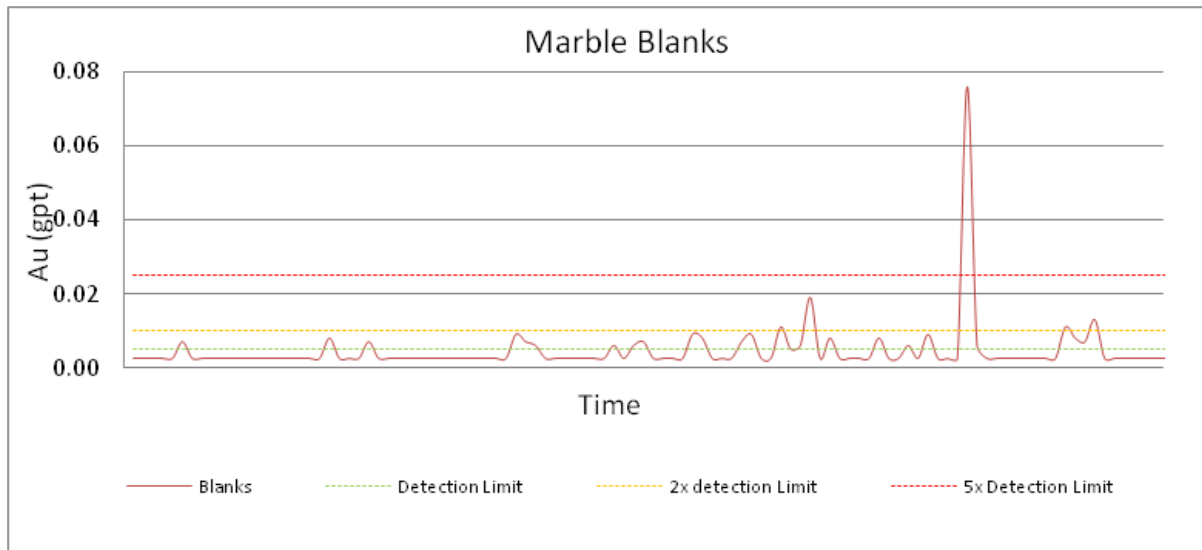

Figure 11-10: Blanks Analytical Results for Au

Of the 340 blanks only one blank analyzed produced a result over 5x the detection limit and was not an appreciable gold response. The blanks consistently provided control as a blank material. There was no mislabels or sequence errors for blank material.

11.7.3 CORE DUPLICATES

Gold Bullion implemented a double duplicate method for core duplicates. A total of 350 assays were compared with 1400 duplicate assays.

11.7.3.1 The Double Duplicate Method

A quarter core split is taken and sent to the laboratory blind as the original for duplicate comparison. An additional half core is sampled and sent to the laboratory with the title “DDUP”, and a quarter core remains as a witness sample. The DDUP samples have special laboratory instructions:

- Each sample bag will contain 4 tickets and their corresponding ticket numbers are written on the bag. The tickets will be in pairs, stapled together; the first pair will be labelled 1A and 1B respectively, and the second pair will be labelled 2A and 2B respectively. These pairing ensure that each pair belongs to a single pulp.
- The contents of one sample bag will be crushed in entirety.
- Instead of one split, two splits will be created both of 250g, if the case where there is less than 500g of crush the split will be two equal portions. From this point, one pair of tickets will accompany first split, and the other pair will accompany the second split.
- Each of the splits will be then pulverized.
- From each pulverized split there will be two assays, 1 assay for each ticket. The assays will all be done by the same method.
- They will be reported by the ticket number.

See Figure 11-11 for a simplified flowsheet of the process.

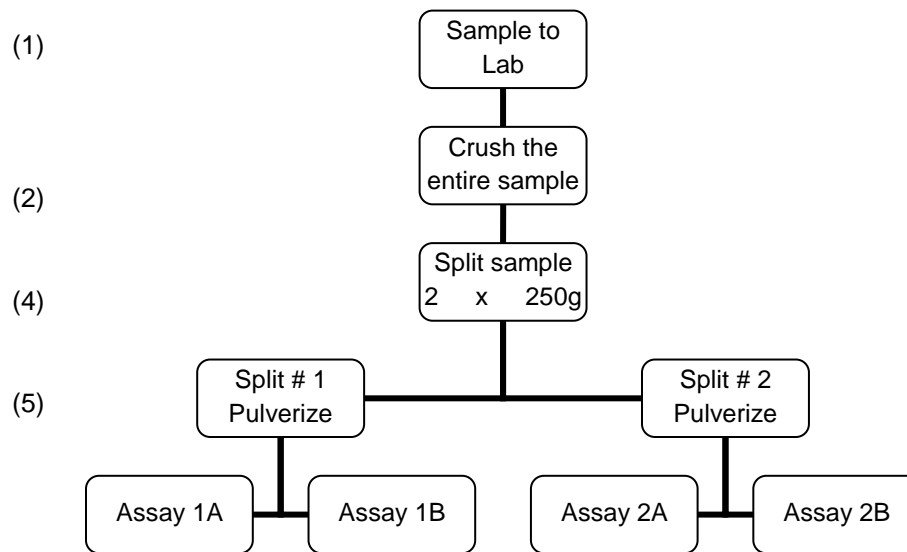

Figure 11-11: Flowsheet for Double Duplicate Process.

11.7.3.2 The Double Duplicate Results

Scatter plots of the ¼ core split gold values versus each of the duplicated values (1A, 1B, 2A, 2B) (Figure 11-12) were created to check if there is the expected linear relationship. Most of the values did not match on a 1:1 line or within the 20% variance, displaying that there appears to be a nugget effect within the deposit. However by comparing the results on a line chart there is a definite relationship with the duplicate results. The nugget effect hypothesis is further solidified by comparing the duplicates that came from the same pulp, the 1A and 1B results (Figure 11-13) and also the 2A and 2B results. When comparing samples produced from the same pulp, the results plot closer to a 1:1 relationship. This indicates there is much less variation within the individual pulps as compared to the entire sample.

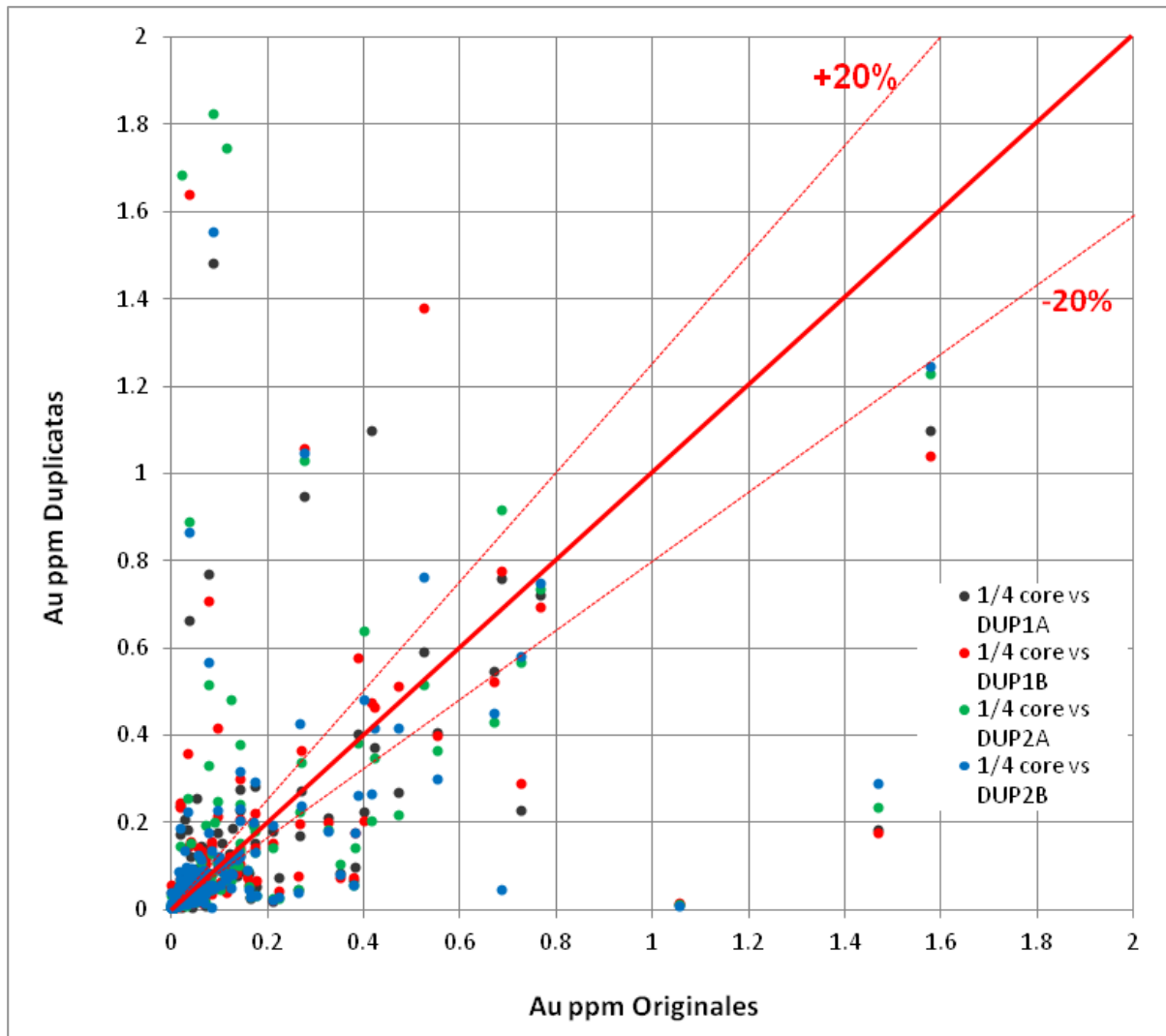

Figure 11-12: Au response of 1/4 core versus duplicates 1A, 1B, 2A, 2B

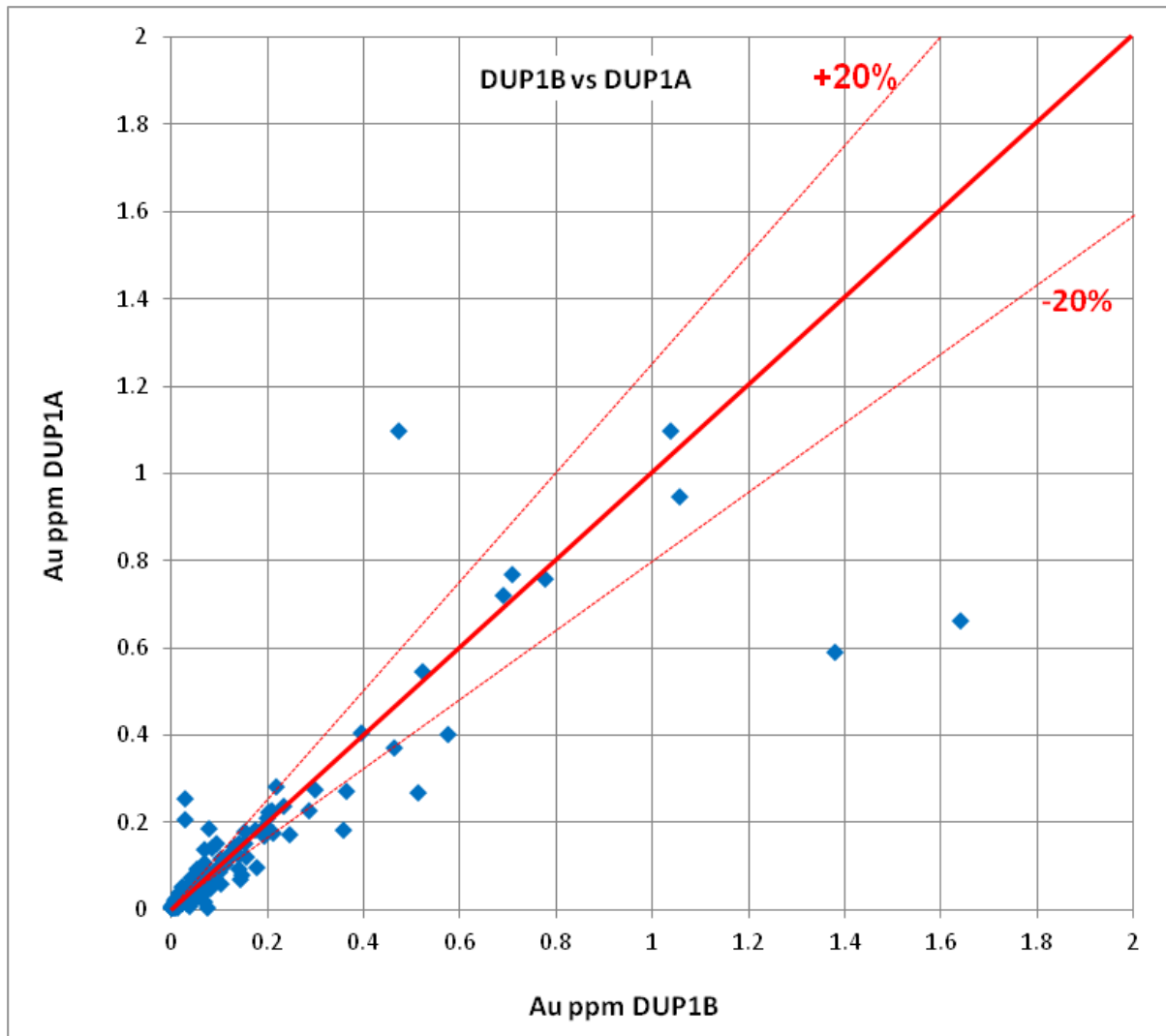

Figure 11-13: Duplicate 1B versus Duplicate 1A

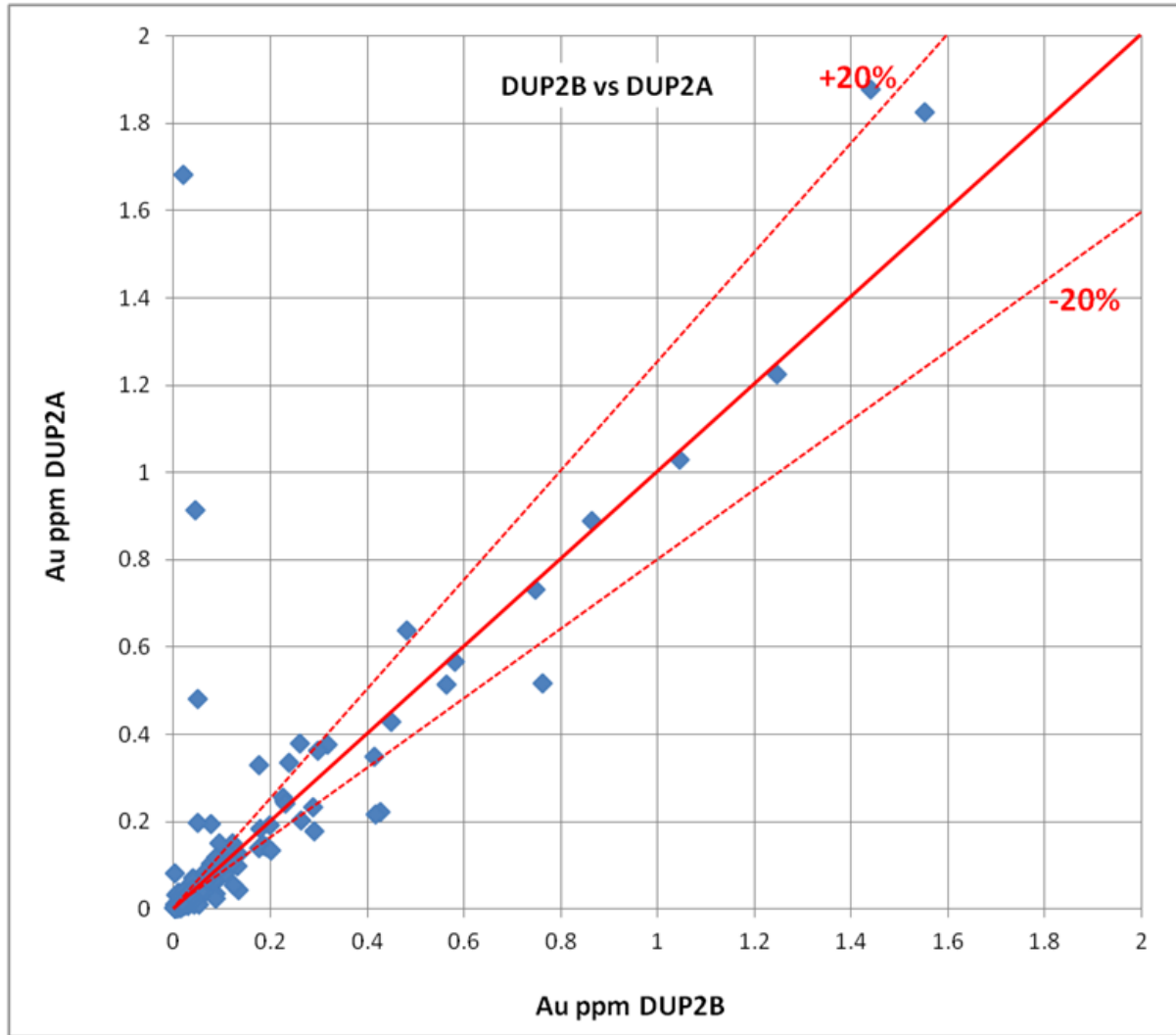

Figure 11-14: Duplicate 2B versus Duplicate 2A

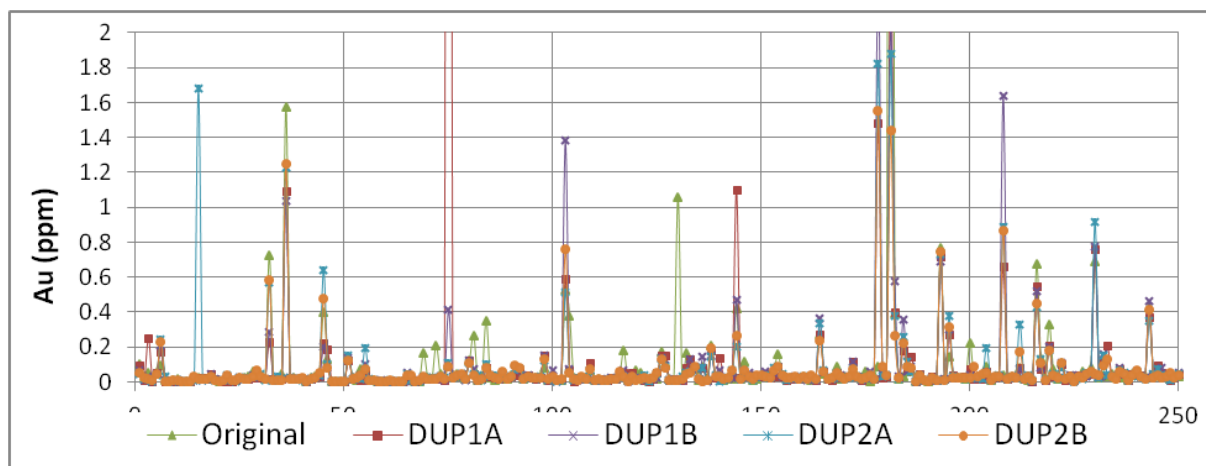

Figure 11-15: Time-scale, Original and Duplicates overlay

11.8 SECURITY

There was a security failure in autumn of 2011 when the previous consultant removed critical project data during a weekend autumn 2011. The author is of the opinion that a chain of custody was probably in place prior to the occurrence of problems between the service provider and the company.

In the author's opinion the sample preparation was adequate as far as we have been able to verify with the laboratories, it was apparently changed over time to have larger amount of rock crushed and pulverized prior to split which is good. As for security there is no reason to believe tampering has occurred as per arguments of the next section and the physical observation of gold in core at the site. The gold fire assay and screen metallic are industry standard for analysis of gold and are acceptable.

The reader should keep in mind that this property is not a green field, mining activities have taken place and previous owners have demonstrated the presence of gold in the ground.

An extensive independent sampling program has been put in place right at the beginning of the mandate in order to compensate the lack of follow-up on previous QA/QC, and also built confidence on the data for preparation of the resource estimate in the context of a nuggetty gold project.

12 Data Verification

12.1 THE INDEPENDENT ANALYTICAL PROGRAM

Since it was not possible to have access to all data up to date, an extreme independent sampling program was set-up. A selection of holes and intersections throughout the deposit was done; a quick log of the cut witness core with checking of the assay tags took place. Afterward the half core samples were bag sealed and sent to SGS laboratory in Toronto. Both 50 gram gold fire assays followed by a screen metallic on 500g to 1 kg sample were requested for each individual sample. Photographs of the core were taken prior to sampling. In addition to this program, sample pulps from the four (4) laboratories were selected for reanalysis. It is important to mention that sample selection was done prior to the final preparation of the database. This has led to the discard of control data could not be matched at the moment of writing the report.

12.1.1 THE DATABASE

The following details the required steps to produce a usable geological database from the received information sets.

After receiving basic information, a field inspection took place to verify the location of drillhole collars in the field. There were two collar information files from the independent surveyor Mazac Geoservices. One was from August 2011 and the second from October 2011. These files have been used as the base for the creation of the new drillhole database. The Geotic file received from Gold Bullion dated September 2011 was incomplete and errors between the drillhole names were observed, in particular between the field survey files and the Geotic log. Moreover, coordinates for some holes in the Geotic file had discrepancies over 1000 m in position while several were in the 5 to 10 meters range. The errors may have occurred by using a combination of the planned collar positions and final surveyed positions from Mazac, particularly in the case when inclinations (dips) were not surveyed and the FlexIT data was not available. Validation of the deviation data along the hole in the Geotic database could not be completed due to the absence of magnetic field measurements.

It was also observed in the assays of Geotic that gold (Au) and beryllium (Be) columns were interchanged. Ian Lafrance from SGS Geostat initiated the tedious quest of rebuilding the database from assay certificates and a partial list in a key Excel file of from-to values, to accurately match the proper gold values to depth.

The blanks and standards reference list were not available. In the file provided approximately 80% of from-to's was relocated and appropriate assay result from original assay certificate have been matched. However, approximately 18,000 m of assays results could still not be matched. The investigation work was performed between November 2011 and February 2012. In February 2012, the company received additional information in paper form of non-validated logs from the previous consultant. Some of this added information was used to extend the database. SGS geologists were sent to the site for quick logging and retrieval of from-to values for certain drillholes to complete the database for the first resource estimate. Even though geological logs were limited, combining the information from the paper logs supplied in February 2012, SGS could removing the incomplete and/or doubtful non validated holes bringing the count of usable holes from the 400's to the 300's.

An additional difficulty arose in the preparation of the assay database: the same sample numbers were used for different holes with different from-to values and from different laboratories. The date of results from the laboratory and drillhole drilling timing was used to organize the data. Partial FlexIT data was provided in February 2012 which helped the validation of certain deviation surveys in some of the holes.

12.1.2 DATABASE VALIDATION 2014

Between Jan 24 2014 and Feb 05 2014 Matthew Halliday GIT from SGS Geostat conducted further validation on the geological database. The database contained some overlapping assay data and as such informed decisions had to be made to better prepare and eliminate overlapping assays from entering block model. Twenty-three samples were identified as potential errors. Eleven samples appear to be simple transcription errors causing very small overlaps, after confirming with excel drillhole logs these values were corrected. Hole number GR-10-17 had multiple overlaps because there were duplicate assays from the analytical lab, the newest values were kept except for one value which came from a larger sample more representative sample. Samples numbered 30058-30061 were removed from GR-10-17. Three more assays were deleted from three other holes for similar reasons. These changes are assumed to not cause any significant changes to the dataset in terms of grade. Addition overlap checks, collar depths were checked to verify no end of hole depths were smaller than the last assay. This validation was performed by incorporating techniques within the GeoBase Validation tool, Access, and Excel.

Using the information from the current validation, minor changes were made to the deviations and lithology tables. For the deviations table, a review of possibly erroneous deviations was conducted and compared to nearby surveys, 80 particular deviations were selected. Of those 80 only a small fraction were selected to be "inactive". Similarly the modifications to the Lithology table were equally minor, most modifications were to change the geological level of lithologies to avoid any potential overlaps, and some faults were given a 1 cm dimensionality. Most of these errors were minor overlap issues, however 19 errors were outside the drillhole limits, in such cases the drill logs were consulted and the appropriate changes made, typically this discrepancy type was within 3m or 1 drill run.

At this time, only the changes to the assays table have been used in the 3d modelling environment, however the other corrections are available for future use.

12.1.3 THE PULP

A decision was made in 2011 to perform a random selection of the pulps stored at site from the four (4) different laboratories. Initially, 646 pulps were selected and taken for 50 gram gold fire assay and even pulp from screen metallic of Accurassay. The picture below (Figure 12-1) presents the storage of pulp crates in the containers, the wood crates were brought inside the logging facility where pulps were sorted, recorded in a computer and bagged for shipping to the SGS Laboratory in Toronto.





Inside building with layout of pulp bags ALS

Listing packing of pulps envelopes Accurassay

Figure 12-1: Independent pulp selection and packing in 2011

The following page presents comparison table from GBB originals versus SGS control.

1	HOLE ID	GBC #	SGS #	Pulp cross check	Au GBB ppb	Au_Met GBB ppb	Au SGS ppb	Au FAG303 g/t	WO SGS	Comments
2	GR-10-136	J208575	33001	ALS	16	-1	15	N.A.	TO118637	
3	GR-10-136	J208576	33002	ALS	63	-1	61	N.A.	TO118637	
4	GR-10-136	J208577	33003	ALS	440	-1	462	N.A.	TO118637	
5	GR-10-136	J208578	33004	ALS	168	-1	97	N.A.	TO118637	
6	GR-10-136	J208579	33005	ALS	25	-1	26	N.A.	TO118637	
7	GR-10-136	J208580	33006	ALS	31	-1	34	N.A.	TO118637	
8	GR-10-136	J208581	33007	ALS	67	-1	66	N.A.	TO118637	
9	GR-10-136	J208582	33008	ALS	27	-1	30	N.A.	TO118637	
10	GR-10-136	J208583	33009	ALS	129	-1	123	N.A.	TO118637	
11	GR-10-136	J208584	33010	ALS	58	-1	64	N.A.	TO118637	
12	GR-10-136	J208585	33011	ALS	58	-1	71	N.A.	TO118637	
13	GR-10-136	J208586	33012	ALS	14	-1	19	N.A.	TO118637	
14	GR-10-136	J208587	33013	ALS	14	-1	16	N.A.	TO118637	
15	GR-10-136	J208588	33014	ALS	423	-1	405	N.A.	TO118637	
16	GR-10-136	J208589	33015	ALS	115	-1	121	N.A.	TO118637	
17	GR-10-136	J208590	33016	ALS	28	-1	25	N.A.	TO118637	
18	GR-10-136	J208591	33017	ALS	5600	740	4340	3	TO118637	
19	GR-10-136	J208592	33018	ALS	141	-1	88	N.A.	TO118637	REP-33018 = 12
20	GR-10-136	J208593	33019	ALS	-5	-1	<5	N.A.	TO118637	
21	GR-10-136	J208594	33020	ALS	18	-1	17	N.A.	TO118637	
22	GR-10-136	J208595	33021	ALS	15	-1	15	N.A.	TO118637	
23	GR-10-136	J208596	33022	ALS	23	-1	20	N.A.	TO118637	
24	GR-10-136	J208597	33023	ALS	30	-1	30	N.A.	TO118637	
25	GR-10-136	J208598	33024	ALS	250	-1	322	N.A.	TO118637	
26	GR-10-136	J208599	33025	ALS	204	-1	520	N.A.	TO118637	
27	GR-10-136	BLANK	33026	ALS	-1	-1	<5	N.A.	TO118637	
28	GR-10-151	J198470	33027	ALS	68	-1	90	N.A.	TO118637	
29	GR-10-151	J198471	33028	ALS	36	-1	30	N.A.	TO118637	

Figure 12-2: Screenshot of comparison pulps database

In the process of trying to connect the pulp assay numbers with reliable data in the database, we ended up with only 588 pulps for comparison for which we could trace with confidence.

The average gold grade of the pulps from the four (4) labs is 252 ppb where as SGS produced 266 ppb. The bias could not be demonstrated with the sign test on these pairs.

12.1.4 THE CORE

A decision was made in 2011 to select continuous samples representing zones instead of selecting individual random samples. Holes and depth intervals were selected from the Geotic based on coverage of the deposit independently of which lab made the analyses. A total of 1,393 assays including inserted blanks were sent to the SGS laboratory in Toronto for sample preparation followed by both a 50 g fire assay and a Screen metallic on 500 to 1kg depending on sample size.



Sample length verification and preparation of tags



Bagging and packing of core



Core rack with selected witness core



Independent sample bags sealed in the
in thaw-zone shipping box

HOLE ID	FROM	TO	GBC #	SGS #	GBC LAB	Au AA23 AA25 ppb	Au Met ppb	ME-ICP41 As ppm	Au SGS ppb	Weight (M) g	Au (M1) g/t	Au (M2) g/t	Weight (P) g	Au(P) g/t	Au (Calc) g/t
GR-10-104	3	4	J357216	31001	ALS	5	-1	30	8	I.S.	I.S.	I.S.	I.S.	I.S.	I.S.
GR-10-104	4	5	J357217	31002	ALS	129	-1	434	163	995	0.08	0.09	69	1.35	0.16
GR-10-104	5	6	J357218	31003	ALS	280	-1	257	331	1004	0.14	0.38	66	0.58	0.28
GR-10-104	6	7	J357219	31004	ALS	83	-1	989	94	998	0.21	0.21	63	<0.03	0.2
GR-10-104	7	8	J357221	31005	ALS	2710	-1	4650	12200	1086	4.51	5.07	68	31.3	6.35
GR-10-104	8	9	J357222	31006	ALS	18	-1	221	25	1019	0.07	0.06	68	<0.03	0.06
GR-10-104	9	10	J357223	31007	ALS	212	-1	18	345	1125	0.18	0.28	58	1.13	0.28
GR-10-104	10	11	J357224	31008	ALS	2590	-1	1360	1710	880	0.84	0.86	67	2.51	0.97
GR-10-104	11	12	J357225	31009	ALS	2120	-1	2260	1700	932	2.18	1.76	69	4.18	2.12
GR-10-104	12	13	J357226	31010	ALS	988	-1	652	888	1154	1.01	1.13	66	0.9	1.06
GR-10-104	13	14	J357227	31011	ALS	609	-1	469	550	871	0.65	0.71	62	17	1.77
GR-10-104	14	15	J357228	31012	ALS	689	-1	1330	212	1042	0.28	0.35	66	0.3	0.31
GR-10-104	15	16	J357229	31013	ALS	98	-1	254	156	1133	0.07	0.11	60	0.49	0.11
GR-10-104	16	17	J357230	31014	ALS	111	-1	797	160	989	0.2	0.16	69	0.16	0.18
GR-10-104	17	18	J357231	31015	ALS	1635	-1	1070	3050	983	1.56	1.78	67	3.41	1.78
GR-10-104	18	19	J357232	31016	ALS	551	-1	21	101	1165	0.12	0.09	63	0.09	0.11
GR-10-104	19	20	J357233	31017	ALS	465	-1	195	771	1162	1.28	2.15	64	2.5	1.76
GR-10-104	20	21	J357234	31018	ALS	10000	-1	446	41400	688	8.08	5.17	56	21.3	7.73
GR-10-104	21	22	J357235	31019	ALS	510	-1	1020	15700	1026	21.1	15.9	61	57.5	20.7
GR-10-104	22	23	J357236	31020	ALS	247	-1	723	165	980	0.22	0.29	64	4.63	0.52
GR-10-104	23	24	J357237	31021	ALS	92	-1	274	39	934	0.07	0.07	51	1.49	0.14
GR-10-104	24	25	J357238	31022	ALS	51	-1	27	70	1119	<0.03	0.04	61	<0.03	0.03
GR-10-104	25	26	J357239	31023	ALS	2.5	-1	17	6	1199	<0.03	<0.03	66	<0.03	0.01
GR-10-104	26	27	J357241	31024	ALS	11	-1	33	18	1075	<0.03	<0.03	59	<0.03	<0.01
GR-10-104	27	28	J357242	31025	ALS	2.5	-1	11	7	1253	<0.03	<0.03	68	<0.03	<0.01
GR-10-104			BLANK	31026					<5	710	<0.03	<0.03	64	<0.03	<0.01
GR-10-104	28	29	J357243	31027	ALS	10	-1	35	155	978	0.26	0.1	65	2.33	0.31
GR-10-104	29	30	J357244	31028	ALS	2.5	-1	39	9	1019	<0.03	<0.03	54	<0.03	<0.01
GR-10-104	30	31	J357245	31029	ALS	11	-1	55	6	982	<0.03	<0.03	58	<0.03	0.01
GR-10-104	31	32	J357246	31030	ALS	10	-1	51	13	834	<0.03	<0.03	67	<0.03	0.01
GR-10-104	32	33	J357247	31031	ALS	9	-1	29	14	906	<0.03	<0.03	53	<0.03	0.01

Figure 12-3: Sample of the comparison database

Removing the samples unmatched with originals or blanks, the initial 1,393 assays is reduced to 1,341 usable assays for comparison. A total sample length of 1,598.31 meters was taken for independent sampling in this phase of the program. This represents nearly 4% of the drill core used in the resource estimate for that part only. If the pulp and the total gold tests core lengths are added to this, then over 5% of drill core in the resource estimate has been tested in the author’s independent sampling program. If the previous consultant had completed their work in full, a significantly smaller amount of independent control samples would have been required.

In comparing all the original assays with the controls, no bias has been detected with the Sign test.

Table 12-1: Sign test and statistics of comparison independent core.

Sign Test			
667	Negative	685	
637	Positive	655	
37	Null		
1341	Pairs		

By use of the sign test 685 is the sum of the sign indicators from a total of 1341 pairs, number of pairs divided by 2 is 670.5. The inferior limit is 0.472692, the superior limit is 0.527308. The sign test value calculated is 0.510713. Since the sign test value is between the inferior and superior values there is no significant bias detected with this method.

	GBB Original	SGS Control
Average	0.42	0.65
Sum grams	559.95	865.59
Sum above 0.3 gpt	490.66	672.77
Average above 0.3 gpt	1.80	2.46

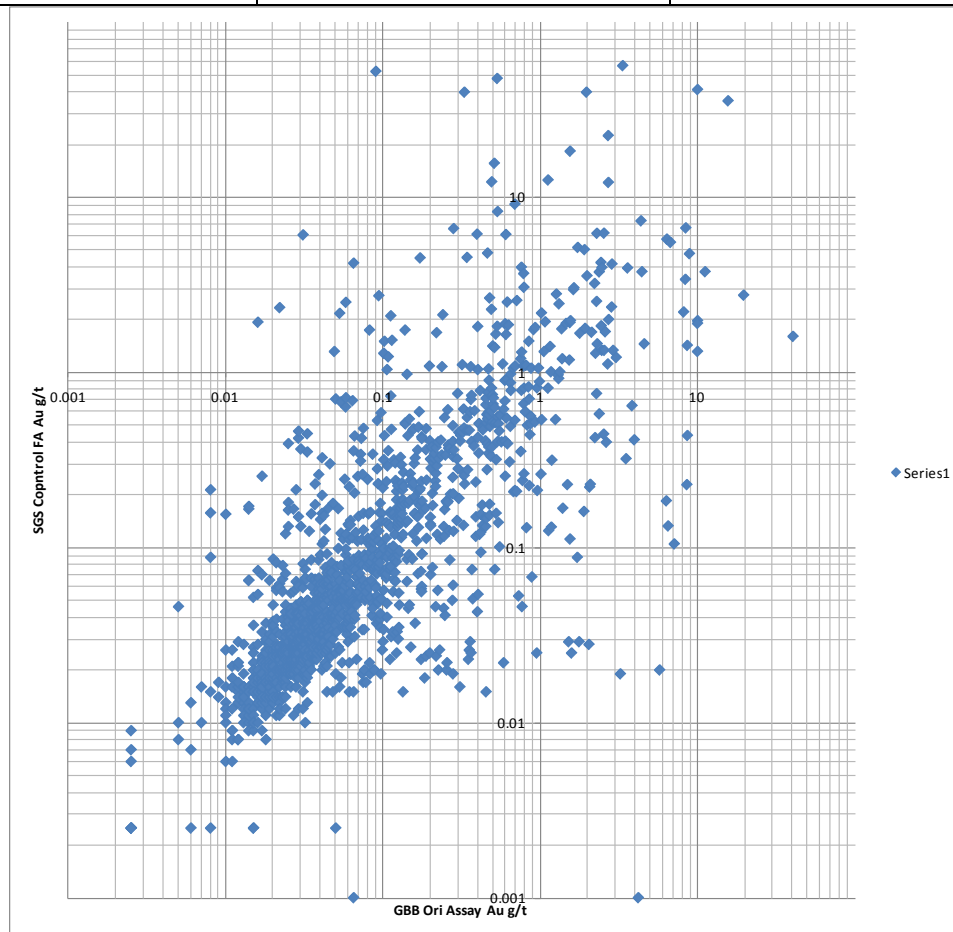

Figure 12-4: Correlation between original sample and control sample half core

The independent sampling of the witness core shows that the original data can be used to produce resource estimates. The author is aware of the variation from taking the second half of core and being in a context of gold with presence of coarse grains.

The average gold grade of the independent sampling is higher than the average grade of the original data. So the existing database is more conservative than highly promotional and can now serve as a base for resource estimation.

Table 12-2: Extract of comparison sample sorted on SGS SM no grade in SM

HOLE ID	FROM	TO	GBC #	SGS #	GBC LAB	Au AA23 AA25 ppb	Au Met ppb	Au SGS ppb	Au(Calc) g/t
GR-10-104	3	4	J357216	31001	ALS	5	-1	8	I.S.
GR-10-104	166.7 5	167.6	J357373	31155	ALS	68	-1	68	I.S.
GR-10-104	131	131.55	J357343	31124	ALS	8420	-1	6710	I.S.
GR-10-104	27	28	J357242	31025	ALS	2.5	-1	7	<0.01
GR-10-104	29	30	J357244	31028	ALS	2.5	-1	9	<0.01
GR-10-104	34	35	J357249	31033	ALS	2.5	-1	<5	<0.01
GR-10-104	35	36	J357250	31034	ALS	2.5	-1	<5	<0.01
GR-11-250	114.5	115	J199214	31464	ALS	2.5	-1	<5	<0.01
GR-10-108	211.9 7	212.65	J757132	32132	ALS	2.5	-1	<5	<0.01
GR-11-250	50.57	51.5	J199154	31405	ALS	6	-1	<5	<0.01
GR-10-108	241.5	243	J757156	32156	ALS	6	-1	7	<0.01
GR-11-250	35.5	36.5	J199138	31389	ALS	7	-1	10	<0.01
GR-11-250	37.92	38.42	J199140	31391	ALS	10	-1	6	<0.01
GR-10-104	26	27	J357241	31024	ALS	11	-1	18	<0.01
GR-10-104	152	153	J357362	31143	ALS	11	-1	9	<0.01
GR-10-193	205	206	4203	32812	Accurassay	11	-1	8	<0.01
GR-11-250	5.48	6.5	J199108	31359	ALS	12	-1	8	<0.01
GR-11-250	76.5	77.96	J199181	31432	ALS	12	-1	15	<0.01
GR-09-04	38.4	39.4	29561	31642	Expert	13	-1	19	<0.01
GR-10-164	4.5	6	3707	32562	Accurassay	13	-1	12	<0.01
GR-11-250	42.5	43.5	J199146	31396	ALS	14	-1	10	<0.01
GR-11-250	102	103.5	J199203	31454	ALS	14	-1	9	<0.01
GR-10-104	118	119	J357330	31112	ALS	15	-1	36	<0.01

GR-11-250	88.5	89.5	J199193	31443	ALS	15	-1	9	<0.01
GR-10-108	240	241.5	J757155	32155	ALS	15	-1	<5	<0.01
GR-09-04	2	3	4243	31605	Accurassay	17	-1	9	<0.01
GR-10-193	192	193	4191	32799	Accurassay	17	-1	18	<0.01
GR-11-250	81	82.5	J199184	31435	ALS	18	-1	8	<0.01
GR-10-193	193	194	4192	32801	Accurassay	19	-1	12	<0.01
GR-10-104	153	154.5	J357363	31144	ALS	20	-1	13	<0.01
GR-10-193	45	46	4041	32652	Accurassay	20	-1	13	<0.01
GR-11-250	261	261.5	J199337	31586	ALS	21	-1	11	<0.01
GR-10-104	151	152	J357361	31142	ALS	50	-1	33	<0.01
GR-11-196	123	124	J198165	31350	ALS	50	-1	<5	<0.01
GR-10-104	55.15	55.9	J357271	31054	ALS	363	-1	<5	<0.01

Table 12-2 shows that no grades in screen metallic make sense with the Fire Assay of GBB and SGS. I.S. is the abbreviation for insufficient sample for Screen Metallic column.

Table 12-3: Extract of comparison sorted on SM (SGS Au Calc g/t)

HOLE ID	FROM	TO	GBC #	SGS #	GBC LAB	Au AA23 AA25 ppb	Au Met ppb	Au SGS ppb	Au(Calc) g/t
GR-10-13	33.5	34	29668	32936	Expert	329	-1	40000	78.5
GR-09-01	35.2	35.5	89436	32011	Expert	90	-1	52600	56.3
GR-11-250	242	242.5	J199322	31571	ALS	1120	3570	12600	21.5
GR-10-104	21	22	J357235	31019	ALS	510	-1	15700	20.7
GR-10-193	56	57	4053	32663	Accurassay	2463	-1	3980	19.8
GR-09-04	106.5	107.5	29590	31701	Expert	15630	-1	35700	18.9
GR-09-04	85.5	86.5	29583	31684	Expert	2704	-1	22600	17.1
GR-09-04	64.3	65.3	29567	31664	Expert	1547	-1	18400	13.1
GR-10-13	32.85	33.5	29666	32935	Expert	491	-1	12300	9.94
GR-11-196	81	82.5	J198133	31317	ALS	342	-1	4550	8.11
GR-10-104	20	21	J357234	31018	ALS	10000	-1	41400	7.73
GR-10-13	38	38.5	29673	32941	Expert	4370	-1	7360	7.15
GR-11-196	66	67.5	J198123	31307	ALS	476	-1	2670	6.77
GR-10-104	7	8	J357221	31005	ALS	2710	-1	12200	6.35
GR-09-01	54.1	55.2	27008	32033	Expert	6380	-1	5790	5.95
GR-11-250	113.5	114	J199212	31462	ALS	1980	-1	3570	5.8

HOLE ID	FROM	TO	GBC #	SGS #	GBC LAB	Au AA23 AA25 ppb	Au Met ppb	Au SGS ppb	Au(Calc) g/t
GR-11-250	262	262.5	J199339	31588	ALS	8880	24600	4780	5.12
GR-10-108	117.5 8	119.0 8	J757061	32061	ALS	2290	-1	6250	5.08
GR-10-99	7.5	8.3	J759748	32504	ALS	1730	-1	5190	4.96
GR-09-04	72.1	73.1	29576	31672	Expert	535	-1	8320	4.91
GR-10-108	204.4 6	205.9 6	J757127	32127	ALS	22	-1	2350	4.85
GR-10-104	197.5	198	J357397	31179	ALS	2430	-1	4260	4.84
GR-10-108	262.9	264	J757172	32171	ALS	31	-1	6120	4.55
GR-10-99	56	57	J759788	32543	ALS	926	-1	522	4.4
GR-10-99	53.2	54	J759785	32540	ALS	6730	-1	5540	4.37
GR-10-18	54	55.5	30080	32844	Expert	2540	-1	6260	4.34
GR-11-220	16.5	18	J205879	31219	ALS	532	-1	47900	4.22
GR-09-01	50.3	51.6	27004	32029	Expert	2855	-1	4170	4.05
GR-10-18	55.5	56.5	30081	32845	Expert	4430	-1	3770	4.01
GR-11-250	177	178.5	J199272	31521	ALS	1265	-1	2810	3.93

A comparison between SGS fire assay and Screen metallic was also been done.

When sorted on screen metallic (SM- Au Calc g/t) and using only results above zero, we get 1,196 screen metallic results received at the time of analysis (108 assay results were not included at time of analysis). The average grade for Original Gold Bullion is 0.42 g/t, SGS FA is 0.60 g/t and the screen metallic average grade is 0.56 g/t.

The exercise of selecting only the comparison assay for SGS SM having a grade above zero in the metallic portion was also done. This gives us 478 samples to compare. The average grade for Original Gold Bullion data for these is 0.90 g/t, SGS FA is 1.40 g/t and the screen metallic average grade is 1.32 g/t., the average grade of the metallic component for these is 7.64 g/t.

Based on these comparisons it appears that actual GBB gold grades are underestimated and requires additional investigation.

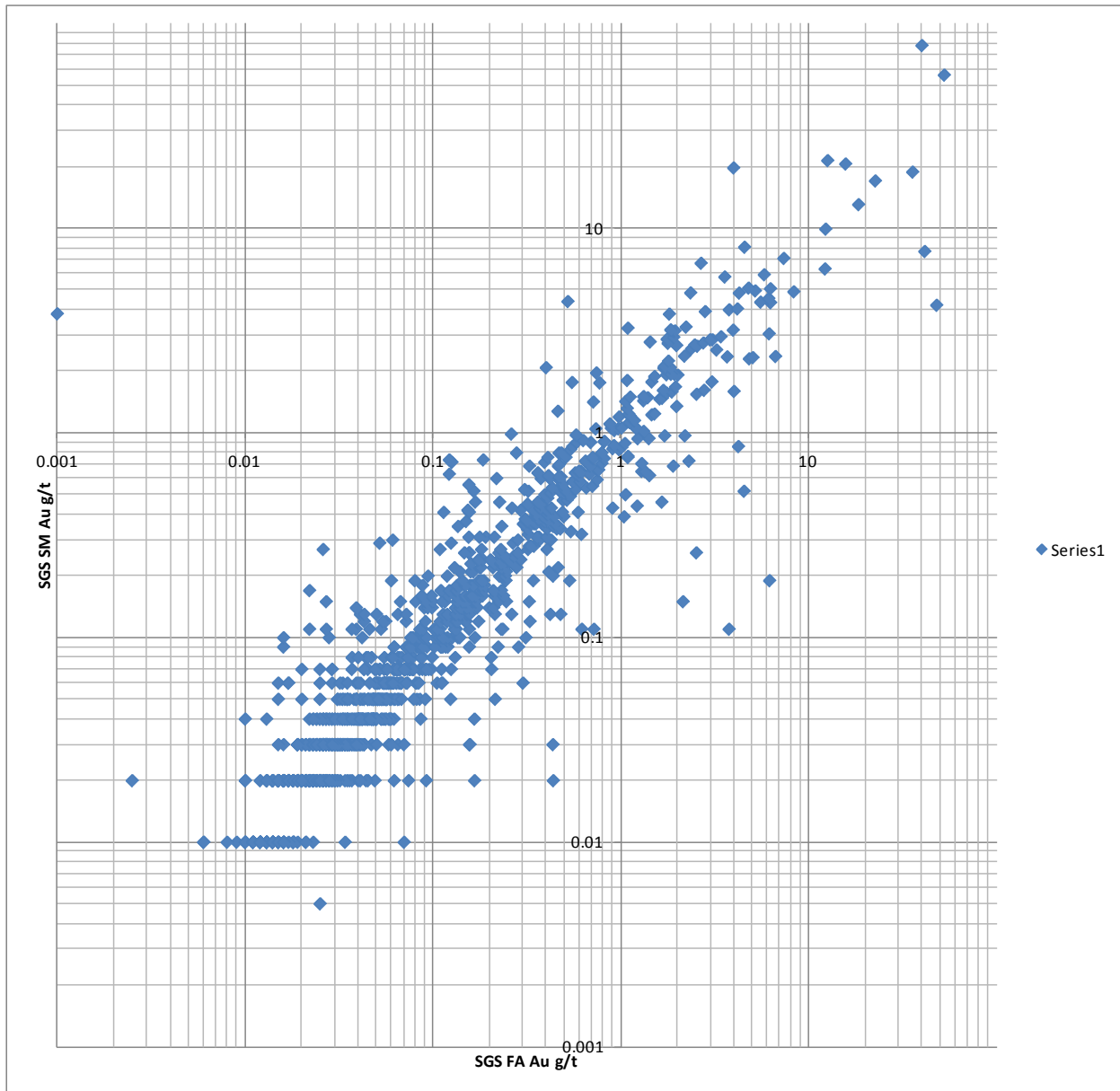

Figure 12-5: Correlation between SGS FA and SGS SM

During the investigation process a second Fire Assay was requested to SGS laboratory, where the first SGS Fire Assay results contained grades above 0, 1,235 assays were compared. In the second set of fire assays three (3) of the 1,235 samples came back below detection limit of 5 ppb; those values were replaced with 3 ppb. The average grades are: the original GBB assays is 410 ppb or 0.41 g/t, first SGS FA assay 621 ppb or 0.62 g/t and the second SGS FA 646 ppb or 0.65 g/t. In addition to the 738 assays below detection limit of first SGS FA run, 3 came back with 12, 17 and 36 ppb which are not significant in author’s opinion.

12.1.5 TOTAL GOLD TEST

In addition to pulp and core sampling, total gold tests on 29 composites were also conducted. The total gold test was carried out on a zone which was composited and the entire composite is processed to define the total amount of gold in the rock. The composite lengths are 8 to 14 meters of core and represent

composite weights in the 20 to 30 kg range. Details of Test are discussed in section 13 of this report and summarized in the following list (Table 12-4).

Table 12-4: List of composite number with associated hole

Hole Name	From	To	Leng	Lithology			Structure		Composite Name	Composit e №	Original Sample Nes	From	To	Lengt h (m)
				From	To	Rock Type	Type	AC						
GR-10-109	18.8	28.8	10	18.8	24.09	S1	S1	60	COMP1	30451	J758529	18.8	20.3	1.5
				24.09	25.37	VQ					J758530	20.3	21.5	1.2
				25.37	28.8	S1					J758531	21.5	23	1.5
											J758532	23	23.8	0.8
											J758533	23.8	24.7	0.9
											J758534	24.7	25.35	0.65
											J758535	25.35	25.86	0.51
											J758537	25.86	27	1.14
											J758538	27	27.7	0.7
			J758539	27.7	28.8	1.1								
GR-10-109	69.5	80.15	10.65	69.5	78.82	S1	S1	55	COMP2	30452	J758573	69.5	71	1.5
				78.82	75.6	BX					J758574	71	72.5	1.5
				75.6	77.02	S1					J758575	72.5	73.9	1.4
				77.02	78.67	VQ					J758576	73.9	74.8	0.9
				78.67	80.15	S1					J758577	74.8	75.6	0.8
											J758579	75.6	77.1	1.5
											J758580	77.1	78.65	
											J758581	78.65	80.15	1.5
GR-10-109	184.9	197.6	12.7	184.9	188.5	QFP	S1	65	COMP3	30453	J758665	184.9	185.9	1
				188.5	189.56	S1					J758666	185.9	186.9	1
				189.56	189.98	VQ					J758667	186.9	187.9	1
				189.98	197.6	S1					J758668	187.9	188.9	1
											J758669	188.9	190.1	1.2
											J758670	190.1	191.6	1.5
											J758671	191.6	193.1	1.5
											J758672	193.1	194.6	1.5
											J758673	194.6	196.1	1.5
											J758674	196.1	197.6	1.5
GR-11-215	24	40.5	16.5	24	40.5	S1	S1	70	COMP4	30454	J209624	24	25.5	1.5
											J209625	25.5	27	1.5
											J209626	27	28.5	1.5
											J209627	28.5	30	1.5
											J209628	30	31.5	1.5
											J209629	31.5	33	1.5
											J209630	33	34.5	1.5
											J209631	34.5	36	1.5
											J209633	36	37.5	1.5
											J209634	37.5	39	1.5
											J209635	39	40.5	1.5
				GR-11-207	54	63					9	54	57.67	S1
57.67	57.9	VQ	J209221				55.5	56.5	1					
57.9	63	S1	J209222				56.5	57.45	0.95					
			J209223				57.45	59.15	1.7					
			J209225				59.15	60	0.85					
			J209226				60	61.5	1.5					
			J209227				61.5	63	1.5					
GR-10-87	8.7	18.75	10.05	8.7	14	S1	S1	65	COMP6	30456	J206090	8.7	10.2	1.5
				14	16.4	VQ					J206091	10.2	11.2	1

Hole Name	From	To	Leng	Lithology			Structure		Composite Name	Composit e №	Original Sample Nes	From	To	Lengt h (m)
				From	To	Rock Type	Type	AC						
				16.4	18.75	S1					J206092	11.2	12.4	1.2
											J206093	12.4	13.8	1.4
											J206094	13.8	15	1.2
											J206095	15	16	1
											J206096	16	17	1
											J206097	17	18	1
											J206098	18	18.75	0.75
GR-10-69	48	61.5	13.5	48	55	S1	S1	60	COMP7	30457	J208301	48	49.5	1.5
				55	55.4	VQ					J208302	49.5	51	1.5
				55.4	61.5	S1					J208303	51	52.5	1.5
											J208304	52.5	54	1.5
											J208305	54	54.82	0.82
											J208306	54.82	55.48	0.66
											J208307	55.48	56	0.52
											J208308	56	57	1
											J208309	57	58.5	1.5
											J208311	58.5	60	1.5
											J208312	60	61.5	1.5
GR-10-31	36	51	15	36	39.34	S1	S1	60	COMP8	30458	2731	36	37.5	1.5
				39.34	39.4	VQ	VQ	60			2732	37.5	39	1.5
				39.4	41.29	MYL	VQ	70			2733	39	40	1
				41.29	41.59	VQ					2734	40	41	1
				41.59	42	MYL					2735	41	42	1
				42	42.38	VQ					2736	42	42.5	0.5
				42.38	42.48	MYL					2737	42.5	43.5	1
				42.48	42.5	VQ					2738	43.5	45	1.5
				42.5	44.48	S1					2739	45	46	1
				44.48	44.52	VQ					2741	46	47	1
				44.52	45.25	S1					2742	47	48.15	1.15
				45.25	45.35	VQ					2743	48.15	49	0.85
				45.35	45.9	S1					2744	49	50.05	1.05
				45.9	46.04	VQ					2745	50.05	51	0.95
				46.04	46.7	S1								
				46.7	48	VQ								
				48	50.14	S1								
				50.14	51	MYL								
GR-10-134	72.7	82	9.3	72.7	73.2	DYKR	S1	70	COMP9	30459	J204225	72.7	74.2	1.5
				73.2	78.7	S1					J204226	74.2	75.3	1.1
				78.7	78.79	VQ					J204227	75.3	76.8	1.5
				78.79	79.9	S2					J204228	76.8	77.8	1
				79.9	80.53	DYKR					J204229	77.8	78.8	1
				80.53	92	S1					J204230	78.8	79.9	1.1
											J204231	79.9	80.5	0.6
											J204232	80.5	82	1.5
GR-10-79	157	169.5	12.5	157	159.06	S1	S1	60	COMP10	30460	J208871	157	158.5	1.5
				159.06	159.15	VQ	VQ	80			J208872	158.5	160	1.5
				159.15	159.96	S1					J208873	160	161.5	1.5
				159.96	160.23	VQ					J208874	161.5	162.65	1.15
				160.23	161.75	SAG					J208875	162.65	163.97	1.32
				161.75	161.86	DYKR					J208876	163.97	165	1.03
				161.86	165.54	S1 (MYL)					J208877	165	165.52	0.52
				165.54	166.56	MYL					J208878	165.52	166.5	0.98

Hole Name	From	To	Leng	Lithology			Structure		Composite Name	Composit e №	Original Sample Nes	From	To	Lengt h (m)
				From	To	Rock Type	Type	AC						
				166.56	166.6	VQ					J208879	166.5	167.5	1
				166.6	167.57	MYL					J208880	167.5	168.5	1
				167.57	167.73	VQ					J208881	168.5	169.5	1
				167.73	169.5	MYL								
GR-10-95	86.62	98.62	12	86.62	91.05	S1	S1	65	COMP11	30461	J726233	86.62	88.12	1.5
				91.05	94.65	VQ	VQ	85			J726234	88.12	89.62	1.5
				94.65	98.62	S1					J726235	89.62	91.12	1.5
											J726237	91.12	92.62	1.5
											J726238	92.62	94.12	1.5
											J726239	94.12	95.62	1.5
											J726240	95.62	97.12	1.5
											J726241	97.12	98.62	1.5
GR-10-67	1.5	15	13.5	1.5	1.97	S1	S1	70	COMP12	30462	44501	1.5	3	1.5
				1.97	1.99	VQ					44502	3	4.5	1.5
				1.99	2.66	S1					44503	4.5	6	1.5
				2.66	2.69	VQ					44504	6	7.5	1.5
				2.69	9.35	S1					44505	7.5	9	1.5
				9.35	9.71	VQ					44506	9	10.5	1.5
				9.71	14.07	S1					44507	10.5	12	1.5
				14.07	14.1	VQ					44508	12	13.5	1.5
				14.1	15	S1					44509	13.5	15	1.5
GR-10-45	135	147	12	135	135.77	S1	S1	65	COMP13	30463	71623	135	136.5	1.5
				135.77	135.84	VQ	VQ	75			71624	136.5	138	1.5
				135.84	138.58	S1					71625	138	139.5	1.5
				138.58	138.8	VQ					71626	139.5	141	1.5
				138.8	147	S1					71627	141	142.5	1.5
											71628	142.5	144	1.5
											71629	144	145.5	1.5
											71630	145.5	147	1.5
GR-10-53	61.5	76.26	14.76	61.5	63.8	S1	S1	75	COMP14	30464	71495	61.5	63	1.5
				63.8	63.84	VQ	VQ	85			71496	63	64.5	1.5
				63.84	65.35	S1					71497	64.5	66	1.5
				65.35	65.4	VQ					71498	66	67.5	1.5
				65.4	66.4	S1					71499	67.5	68.8	1.3
				66.4	70.17	VQ					71500	68.8	70.5	1.7
				70.17	71.85	S1					71501	70.5	72	1.5
				71.85	71.88	VQ					71502	72	73.3	1.3
				71.88	72.26	S1					71503	73.3	74.8	1.5
											71504	74.8	76.26	1.46
GR-11-197	52.5	63	10.5	52.5	53.09	S1	S1	60	COMP15	30465	J198027	52.5	53	0.5
				53.09	53.12	VQ	VQ	80			J198028	53	53.5	0.5
				53.12	53.49	S1					J198029	53.5	54	0.5
				53.49	55.1	VQ					J198030	54	54.5	0.5
				55.1	56.13	S1					J198031	54.5	55	0.5
				56.13	56.17	VQ					J198032	55	55.5	0.5
				56.17	56.69	S1					J198033	55.5	56	0.5
				56.69	56.86	VQ(MYL)					J198035	56	56.5	0.5
				56.86	57.96	S1					J198036	56.5	57	0.5
				57.96	58	VQ					J198037	57	58.5	1.5

Hole Name	From	To	Leng	Lithology			Structure		Composite Name	Composit e №	Original Sample Nes	From	To	Lengt h (m)
				From	To	Rock Type	Type	AC						
				58	60.84	S1					J198038	58.5	60	1.5
				60.84	61.25	VQ					J198039	60	61.5	1.5
				61.25	61.55	S1					J198040	61.5	63	1.5
				61.55	61.84	VQ								
				61.84	62.96	S1								
				62.96	63	VQ								
GR-10-133	54	67.5	13.5	54	54.83	S1	S1	65	COMP16	30466	J357193	54	54.75	0.75
				54.83	55.06	VQ	VQ	90			J357194	54.75	55.75	1
				55.06	56	S1	VQ	70			J357195	55.75	56.5	0.75
				56	56.14	VQ					J357196	56.5	57.5	1
				56.14	56.5	S1					J357197	57.5	58.5	1
				56.5	56.51	VQ					J357198	58.5	60	1.5
				56.51	56.86	S1					J357199	60	61.5	1.5
				56.86	57.09	VQ					J357201	61.5	63	1.5
				57.09	57.63	S1					J357202	63	64	1
				57.63	57.66	VQ					J357203	64	65	1
				57.66	57.94	S1					J357204	65	66	1
				57.94	58.04	VQ					J357205	66	67.5	1.5
				58.04	58.68	S1								
				58.68	58.76	VQ								
				58.76	60.82	S1								
				60.82	61.09	VQ								
				61.09	61.72	S1								
				61.72	61.75	VQ								
				61.75	64.43	S1								
				64.43	64.5	VQ								
				64.5	67.5	S1								
GR-10-137	17	28	11	17	20.46	S2	S1	40	COMP17	30467	4512	17	18	1
				20.46	22.7	DYKR	VQ	40			4513	18	19	1
				22.7	27.29	S2					4514	19	20	1
				27.29	27.48	VQ					4515	20	21	1
				27.48	28	S1					4516	21	22	1
											4517	22	23	1
											4518	23	24	1
											4519	24	25	1
											4520	25	26	1
											4521	26	27	1
											4523	27	28	1
GR-10-42	39.5	52.92	13.42	39.5	44.5	S1	S1	60	COMP18	30468	43253	39.5	41	1.5
				44.5	44.6	VQ	VQ	80			43254	41	42.5	1.5
				44.6	48.14	S1					43255	42.5	44	1.5
				48.14	48.2	VQ					43256	44	45.5	1.5
				48.2	54.92						43257	45.5	47	1.5
											43258	47	48.5	1.5
											43259	48.5	50	1.5
											43260	50	51.17	1.17
											43261	51.17	52.92	1.75
GR-10-42	52.92	64.54	11.62	52.92	53.27	S1	S1	60	COMP19	30469	43262	52.92	54.28	1.36
				53.27	53.59	VQ	VQ	80			43263	54.28	56	1.72
				53.59	55.02	S1					43264	56	58	2
				55.02	55.05	VQ					43265	58	59.5	1.5
				55.05	56.5	S1					43267	59.5	61.3	1.8
				56.5	56.6	VQ					43268	61.3	62.8	1.5

Hole Name	From	To	Leng	Lithology			Structure		Composite Name	Composit e №	Original Sample Nes	From	To	Lengt h (m)
				From	To	Rock Type	Type	AC						
				56.6	57.52	S1					43269	62.8	64.54	1.74
				57.52	57.79	VQ								
				57.79	64.54	S1								
GR-10-167	23.9	33	9.1	23.9	24.4	VQ	S1	40	COMP20	30470	J760663	23.4	24.4	1
				24.4	25.83	QFP?	VQ	70			J760664	24.4	25.4	1
				25.83	30.9	S1					J760665	25.4	26	0.6
				28.9	29.08	VQ					J760666	26	27.5	1.5
				29.08	30.9	S1					J760667	27.5	28.9	1.4
				30.9	31.5	VQ					J760668	28.9	29.6	0.7
				31.5	33	S1					J760669	29.6	30.5	0.9
											J760670	30.5	31.5	1
											J760671	31.5	33	1.5
GR-10-84	148.7	160	11.3	148.7	148.86	S1	S1	40	COMP21	30471	204570	148.7	150.2	1.5
				148.86	148.89	VQ	VQ	60			204571	150.2	151.7	1.5
				148.89	153.86	S1					204572	151.7	153	1.3
				153.86	154.25	VQ					204573	153	154	1
				154.25	155.17	S1					204574	154	155	1
				155.17	155.56	VQ					204575	155	156	1
				155.56	160	S1					204576	156	157	1
											204577	157	158.5	1.5
											204578	158.5	160	1.5
GR-10-169	68.5	82.5	14	68.5	70.46	S1	S1	60	COMP22	30472	J760785	68.5	69	0.5
				70.46	70.5	VQ	VQ	70			J760786	69	70	1
				70.5	76.45	S1					J760787	70	71	1
				76.45	77.17	VQ					J760788	71	71.5	0.5
				77.17	78.14	S1					J760789	71.5	72	0.5
				78.14	78.48	VQ					J760790	72	73	1
				78.48	82.27	S1					J760791	73	74	1
				82.27	82.34	VQ					J760792	74	75	1
				82.34	82.5	S1					J760793	75	76.5	1.5
											J760794	76.5	78	1.5
											J760795	78	79.5	1.5
											J760796	79.5	81	1.5
											J760797	81	82.5	1.5
GR-11-237	79	89	10	79	81.21	S2	S1	55	COMP23	30473	1041305	79	80	1
				81.21	81.58	VQ	VQ	50			1041306	80	81	1
				81.58	83.75	S2	VQ	70			1041307	81	82	1
				83.75	83.85	VQ					1041308	82	82.8	0.8
				83.85	81.11	S2					1041310	82.8	84	1.2
				81.11	81.17	VQ					1041311	84	85	1
				81.17	88	S2					1041312	85	86	1
				88	88.03	VQ					1041313	86	87	1
				88.03	89	S2					1041314	87	88	1
											1041315	88	89	1
GR-10-141	62.79	73.87	11.08	62.79	63.94	MYL	S1	35	COMP24	30474	J756447	62.79	64.13	1.34
				63.94	67.91	S2(S1)	VQ	65			J756448	64.13	65.63	1.5
				67.91	68.1	QFP?					J756449	65.63	67.13	1.5
				68.1	69.32	S2					J756450	67.13	68.63	1.5
				69.32	69.54	QFP?					J756451	68.63	70.13	1.5
				69.54	71.2	S1					J756452	70.13	71.13	1
				71.2	73.87	VQ					J756453	71.13	72.63	1.5
											J756454	72.63	73.87	1.24

Hole Name	From	To	Leng	Lithology			Structure		Composite Name	Composit e №	Original Sample Nes	From	To	Lengt h (m)
				From	To	Rock Type	Type	AC						
GR-10-113	91.5	102.45	10.95	91.5	94.37	S1	S1	65	COMP25	30475	J761822	91.5	93	1.5
				94.37	94.41	VQ	VQ	90			J761823	93	94.5	1.5
				94.41	97.23	S1	VQ	65			J761824	94.5	96	1.5
				97.23	97.71	VQ					J761825	96	97	1
				97.71	98.12	S1					J761826	97	98.18	1.18
				98.12	100.47	MYL					J761827	98.18	99.68	1.5
				100.47	100.97	VQ/MYL					J761828	99.68	101.26	1.58
				100.97	101.72	MYL					J761829	101.26	102.45	1.19
				101.72	101.77	VQ								
				101.77	102.23	MYL								
				102.23	102.28	VQ								
102.28	102.45	MYL												
GR-10-55	110.64	127.14	16.5	110.64	111.58	S2	S1	65	COMP26	30476	A43895	110.64	112.14	1.5
				111.58	112.28	VQ	VQ	65			A43896	112.14	113.64	1.5
				112.28	112.72	S1	VQ	90			A43897	113.64	115.14	1.5
				112.72	112.79	VQ					A43898	115.14	116.64	1.5
				112.79	113.36	S1					A43899	116.64	118.14	1.5
				113.36	113.39	VQ					A43900	118.14	119.64	1.5
				113.39	116.96	S1					A43901	119.64	121.14	1.5
				116.96	117.23	VQ					A43903	121.14	122.64	1.5
				117.23	118.26	S1					A43904	122.64	124.14	1.5
				118.26	118.41	VQ					A43905	124.14	125.64	1.5
				118.41	118.93	S1					A43906	125.64	127.14	1.5
				118.93	119.27	VQ								
				119.27	123.56	S1								
				123.56	124.13	VQ								
				124.13	125.16	S1								
125.16	125.32	VQ												
125.32	127.14	S2												
GR-10-172	96.5	108.5	12	96.5	96.88	S1	S1	60	COMP27	30477	J357041	96.5	97.5	1
				96.88	97.29	VQ	VQ	90			J357042	97.5	99	1.5
				97.29	102.66	S2	VQ	30			J357043	99	100	1
				102.66	103.07	VQ					J357044	100	100.6	0.6
				103.07	105.08	S1					J357045	100.6	102	1.4
				105.08	105.3	VQ					J357046	102	103.5	1.5
				105.3	105.83	S1					J357047	103.5	104	0.5
				105.83	106	VQ					J357048	104	105.5	1.5
				106	108.5	S1					J357049	105.5	107	1.5
											J357050	107	108.5	1.5
				GR-10-45	122	135	13	122			123.85	S1	S1	45
123.85	123.87	VQ							71615	123.5	125	1.5		
123.87	125.73	S1							71616	125	126.5	1.5		
125.73	125.75	VQ							71617	126.5	128.63	2.13		
125.75	128.72	S1							71618	128.63	130.3	1.67		
128.72	130	VQ-CC							71619	130.3	132	1.7		
130	131.35	S1							71621	132	133.5			
131.35	131.68	VQ (MYL)							71622	133.5	135	1.5		
131.68	134.51	S1										1.5		
134.51	135	VQ												
GR-10-70	39.4	54.4	15	39.4	40	S1	S1	70	COMP29	30479	J757212	39.4	40.9	1.5
				40	40.44	VQ	VQ	90			J757213	40.9	42.4	1.5

Hole Name	From	To	Leng	Lithology			Structure		Composite Name	Composit e №	Original Sample Nes	From	To	Lengt h (m)
				From	To	Rock Type	Type	AC						
	40.44	40.78		S1	VQ	70			J757214	42.4	43.9	1.5		
	40.78	40.79		VQ					J757215	43.9	45.4	1.5		
	40.79	41.3		S1					J757216	45.4	46.9	1.5		
	41.3	41.34		VQ					J757217	46.9	48.4	1.5		
	41.34	43.6		S1					J757218	48.4	49.9	1.5		
	43.6	44.08		VQ					J757219	49.9	51.4	1.5		
	44.08	50.5		S1					J757220	51.4	52.9	1.5		
	50.5	50.7		VQ					J757221	52.9	54.4	1.5		
	50.7	51.07		S1										
	51.07	51.11		VQ										
	51.11	51.33		S1										
	51.33	50.5		VQ										
	50.5	54.4		S1										

The sign test did not show bias based on individual comparison.

Table 12-5: Sign test on total gold

Sign Test		
19	Negative	19
10	Positive	10
0	Null	
29	Pairs	

By use of the sign test, the sum of the sign indicators is 19, from a total of 29 pairs; number of pairs divided by 2 is 14.5. The inferior limit is 0.314304662 (Equation 12-1), the superior limit is 0.685695338 (Equation 12-2). The sign test value calculated is 0.655172414. Since the sign test value is between the inferior and superior values there is no significant bias detected with this method.

Equation 12-1
$$L.I. = 0.5 - \frac{1}{\sqrt{n}} = 0.5 - \frac{1}{\sqrt{29}} = 0.3143$$

Equation 12-2
$$L.S. = 0.5 + \frac{1}{\sqrt{n}} = 0.5 + \frac{1}{\sqrt{29}} = 0.6857$$

The comparison of the average original Gold Bullion Fire Assay versus the SGS Lakefield total gold test show the FA are higher than the average total gold. This justifies the application of capping on individual fire assay even if individual assay shows average lower grade than control SGS individual assays bring confidence to the Gold Bullion exploration data.

With the observations and conclusions from the exhaustive independent sampling program, the newly validated Gold Bullion database can be used for resource estimation (RE) with confidence. The deep holes of Phase 1 to 3 without reliable surveys (not used in the current RE) will have to be resurveyed along the hole or discarded, unless original Reflex measurements with magnetic field readings are found. The 2012 deep holes are reliable for resource estimation.

13 Mineral Processing and Metallurgical Testing

13.1 SGS LAKEFIELD TESTWORK- PROJECT 13526-001 (DECEMBER 2011 – JANUARY 2012)

A series of metallurgical tests were carried out at SGS Lakefield on 29 composite samples from the Granada deposit in order to determine the most probable head grade of the mineralization. The samples in their entirety were processed through gravity separation followed by cyanide leaching of the gravity tailings. An overall gravity separation plus cyanidation metallurgical balance was applied to calculate the head grade of each composite sample. The results are shown in Table 13-1 below.

Table 13-1: Composite head grades

GOLD BULLION - PROJET GRANADA					
COMPOSITE	GRAVITY	CYANISATION	O'ALL AU RECOVERY	FINAL TAILINGS	HEAD
IDENTIFICATION	Au RECOVERY	Au EXTRACTION	GRAVITY/CYANIDATION	ASSAY	CALC
	%	%	%	Au, g/t	Au, g/t
Comp. 1	29.6	88.2	91.7	0.079	0.95
Comp. 2	43.7	87.2	92.8	0.037	0.51
Comp. 3	38.5	79.1	87.1	0.035	0.28
Comp. 4	51.2	90.7	95.5	0.025	0.53
Comp. 5	30.5	88.2	91.8	0.024	0.29
Comp. 6	42.3	86.3	92.1	0.026	0.33
Comp. 7	25.1	91.9	93.9	0.015	0.24
Comp. 8	51.7	91.2	95.7	0.022	0.52
Comp. 9	58.9	92.8	97.0	0.019	0.63
Comp. 10	74.5	94.2	98.5	0.021	1.45
Comp. 11	55.8	91.5	96.2	0.059	1.56
Comp. 12	52.4	86.4	93.5	0.052	0.80
Comp. 13	50.5	88.7	94.4	0.038	0.69
Comp. 14	66.4	93.5	97.8	0.057	2.59
Comp. 15	44.4	87.6	93.1	0.064	0.94
Comp. 16	63.0	89.2	96.0	0.050	1.24
Comp. 17	50.3	81.9	91.0	0.017	0.19
Comp. 18	78.0	89.7	97.7	0.036	1.59
Comp. 19	54.5	85.7	93.4	0.102	1.38
Comp. 20	52.8	88.1	94.4	0.080	1.42
Comp. 21	26.6	85.3	89.2	0.026	0.25
Comp. 22	40.5	94.0	96.4	0.034	0.94
Comp. 23	39.1	83.5	90.0	0.042	0.41
Comp. 24	41.1	85.5	91.5	0.110	1.29
Comp. 25	64.6	92.6	97.4	0.018	0.68
Comp. 26	39.9	89.0	93.4	0.071	1.06
Comp. 27	70.2	89.4	96.8	0.046	1.44
Comp. 28	73.1	91.0	97.6	0.039	1.60
Comp. 29	57.5	86.6	94.3	0.047	0.82
Total					
Average	50.6	88.6	94.1	0.045	0.92

Because of a possible misinterpretation of the block model by a former company, it was discovered afterward that some of the composite samples came from drillholes that were outside the known boundary of the deposit. In order to correct the situation and to come up with a more exact deposit head grade, composite samples 3, 5, 7, 17, and 21 were discarded from the SGS Lakefield met tests.

The new results of the met tests are given in Table 13-2 below.

Table 13-2: Met test results

GOLD BULLION - PROJET GRANADA LESS HEAD GRADES < 0.30 g/t					
COMPOSITE	GRAVITY	CYANIDATION	TOTAL AU RECOVERY	FINAL	HEAD
IDENTIFICATION	Au RECOVERY (%)	Au EXTRACTION (%)	GRAVITY / CYANIDATION (%)	ASSAY Au (g/t)	CALC Au (g/t)
Comp. 1	29.6	88.2	91.7	0.079	0.95
Comp. 2	43.7	87.2	92.8	0.037	0.51
Comp. 4	51.2	90.7	95.5	0.025	0.53
Comp. 6	42.3	86.3	92.1	0.026	0.33
Comp. 8	51.7	91.2	95.7	0.022	0.52
Comp. 9	58.9	92.8	97.0	0.019	0.63
Comp. 10	74.5	94.2	98.5	0.021	1.45
Comp. 11	55.8	91.5	96.2	0.059	1.56
Comp. 12	52.4	86.4	93.5	0.052	0.80
Comp. 13	50.5	88.7	94.4	0.038	0.69
Comp. 14	66.4	93.5	97.8	0.057	2.59
Comp. 15	44.4	87.6	93.1	0.064	0.94
Comp. 16	63.0	89.2	96.0	0.050	1.24
Comp. 18	78.0	89.7	97.7	0.036	1.59
Comp. 19	54.5	85.7	93.4	0.102	1.38
Comp. 20	52.8	88.1	94.4	0.080	1.42
Comp. 22	40.5	94.0	96.4	0.034	0.94
Comp. 23	39.1	83.5	90.0	0.042	0.41
Comp. 24	41.1	85.5	91.5	0.110	1.29
Comp. 25	64.6	92.6	97.4	0.018	0.68
Comp. 26	39.9	89.0	93.4	0.071	1.06
Comp. 27	70.2	89.4	96.8	0.046	1.44
Comp. 28	73.1	91.0	97.6	0.039	1.60
Comp. 29	57.5	86.6	94.3	0.047	0.82
Average	54.0	89.3	94.9	0.049	1.07

13.1.1 METALLURGICAL TESTING

The prime objective of the metallurgical testwork was to determine the head grade of each composite by subjecting the entire sample to gravity concentration of the coarse gold followed by cyanide leaching of the gravity tailings. An overall (gravity plus cyanidation) gold metallurgical balance was applied to calculate the head grade of each sample and the total gold recovery.

13.1.1.1 Gravity Separation

For the gravity testwork, each composite sample was ground in a laboratory rod mill to a target of P₈₀ particle size of 75 µm. The mill product was passed through a 3-inch Knelson concentrator. The Knelson concentrate was cleaned on a Mozley table. Both the Mozley and Knelson tailings were combined and submitted to cyanide leaching.

The gold recovery to the gravity concentrates ranged from 29.6% to 78% with an average of 54.0%.

13.1.1.2 Cyanidation

The combined Knelson and Mozley table tailings were subjected to cyanide leaching under the following conditions:

Pulp density	40% solid
Particles size	P ₈₀ 75 µm
pH	10.5 to 11.0 maintained with hydrated lime
Cyanide concentration	0.5 g/L NaCN
Cyanidation time	48 hours
Air addition	≈2 L/min
Test mode	Reactor vessel with mechanical agitator

The extraction of gold by cyanidation ranged from 83.5% to 94% with an average of 89.3%. The NaCN and lime consumptions ranged from 0.03 to 1.40 kg/t and 0.21 to 0.70 kg/t respectively. The overall extraction, gravity plus cyanidation ranged from 90.0 to 98.5% with an average of 94.9%.

13.1.2 SGS LAKEFIELD TESTWORK - PROJECT 14041-001 (MARCH – APRIL 2013)

The purpose of this second test program was to determine the amenability of the sample to coarse gravity separation and flotation. The original test program included dense media separation, flash flotation and cyanidation testwork. The sections below present and summarize the results of testwork that was completed on these new Granada samples.

13.1.2.1 Specific Gravity

Seventeen (17) of the individual core samples which were used for the Master Composite were submitted for density measurements. The initial rock weight, weight in water and water displacement was recorded. The weights were then used to calculate the specific gravity of the ore which was found to be 2.78.

13.1.2.2 Head Analysis

Four (4) gold size fraction analyses were completed on the Master Composite sample. The gold head grade for the -¼” Master Composite sample was 1.39 g/t. The gold head grade for the three size fractions which were created by screening at 4 mm and 1.18 mm ranged from 0.43 g/t to 1.35 g/t.

13.1.2.3 Comminution

The Master Composite sample was submitted for a standard Bond abrasion test. The results of this test can be used to determine steel media and liner wear in crushers, rod mills and ball mills. The Abrasion Index (AI) was 0.247 g and the sample was classified as medium abrasive.

A Bond low-energy impact test was performed on twenty rock samples from the Granada site. Twenty rocks in the range of 2” to 3” were selected and shipped to Phillips Enterprises LLC for the completion of a Bond low-energy impact test. The CWI average was 19.2 kWh/t and fell in the very hard hardness-range.

13.1.2.4 Heavy Liquid Separation

Two samples (-¼” +4 mm and -4 mm +1.18mm) were submitted for heavy liquid separation (HLS) testing. The samples were placed in separatory funnels containing heavy liquid (methylene iodide) at six specific gravities, 3.1, 3.0, 2.9, 2.8, 2.75 and 2.7. The test was carried out sequentially starting with the sample run of highest SG (3.1), creating a float and sink fraction. The float fraction was cleaned, dried, weighed and then run at the next lowest SG. The minerals lighter than the heavy liquid specific gravity floated and those denser sank. The sink fraction and final float (2.7 SG) from each test were submitted for gold analysis.

The results indicated that 69.2% of the gold was recovered at a mass recovery of 30.6%. In order to get a higher gold recovery a larger mass recovery is required.

The results for the -4 mm +1.18 mm Master Composite test indicated that there was improved separation at a finer fraction compared to the coarser fraction (-¼” + 4 mm). A mass recovery of 30.5% yielded a gold recovery of 79.3%, approximately 10% higher than the coarser fraction results. It should also be noted that the 2.70 float was very low grade, 0.05 g/t Au. Additional testwork at a finer crush size (6 mesh) was recommended by SGS.

13.1.2.5 Metallurgical Testing

The original testwork program included dense media separation (DMS) testwork on the -¼” +4 mm and -4 mm +1.18 mm samples. Dense media separation was going to be used to preconcentrate the minerals and reject gangue materials prior to flotation testwork (float fraction) and cyanidation testwork (sink fraction). Based on the HLS test results Gold Bullion decided not to engage in the DMS testwork.

A Wilfley shaking table was used to complete one single pass Wilfley test on the -1.18 mm Master Composite sample. The target concentrate weights were 1%, 2%, 5%, 10% and 15% of the feed weight. The concentrates from the test were going to be used for cyanidation testwork and the Wilfley tailings were going to be used for flotation and cyanidation testwork. The Wilfley table products were dried, weighed and assayed for gold.

Eight (8) concentrate samples were collected during the Wilfley test and combined to create weight fractions close to the target values. These concentrates were dried, weighed and assayed for gold. The calculated gold head grade for the -1.18 mm Master Composite sample was 1.31 g/t which compared well to the gold size fraction analysis value, 1.35 g/t Au.

Table 13-3: Wilfley test results

Product	Weight %	Assay, g/t Au	Recovery % Au
Conc 1-2	1.3	32.0	32.4
Conc. 3	6.5	1.39	6.9
Conc. 4-5	12.2	3.67	34.1
Conc. 6-8	18.4	0.25	3.5
Tails	61.7	0.49	23.2
Head (calc.)	100.0	1.31	100.0

Based on the Wilfley table test results Gold Bullion decided not to pursue the flotation and cyanidation testwork.

13.1.3 GEKKO SYSTEMS PTY. LIMITED TESTWORK – REPORT T1037 (APRIL – JULY 2013)

The purpose of Gekko’s testwork was to build upon the previous scoping program, which found that the Gold Bullion Granada ore was amenable to coarse gravity recovery and fine flotation. Additional tests such as gravity (Falcon), coarse flotation and leaching were added to the original scope of the testwork.

13.1.3.1 Head Grade Analysis

The head grade analysis of the dense media separation feed at a crushed size range of -4 mm to +1.18 mm showed a head assay of 1.23 g/t whilst the calculated grade was 0.47 g/t Au. In one of the four (4) repeat fire assays, a reading of 3.75 g/t Au was evident, which indicates a presence of coarse or ‘spotty’ gold in the dense media separation feed sample.

The table feed crushed to 100% passing 1.18 mm, also indicated the presence of spotty or coarse gold. The average head assay was 1.03 g/t and a calculated grade obtained by the feed sizing was 0.97 g/t Au. This is supported by the higher LeachWell grade (2.06 g/t) than the fire assay grade of the single pass table feed sizing; this can be caused by ‘spotty’ gold that is captured by the LeachWell test but may be exacerbated in a 50 g fire assay.

13.1.3.2 Comminution

The sample had an impact crushing work index of 19.3 kWh/tonne with a range from of 6.1 to 33 kWh/tonne. The abrasion index of the sample was 0.287.

Vertical shaft impact (VSI) crushing (Barmac) produced high circulating loads that indicated low amenability to this comminution technique.

13.1.3.3 Dense Media Separation

Dense media separation tests indicated gold recovery to be at 70% in a mass yield of 4.3% of the feed at a cumulative grade of 19.4 g/t. Approximately 70% of the feed material resided in the -4 mm to +1.18 mm size fraction for DMS cyclone test. The total calculated grade (tail grade) of sinks (SG of 2.9) to floats (SG of 2.7) was 0.35 g/t Au. A tail grade of 0.35g/t was attributed to the residual material from the dense media separation test. This represented approximately 96% of the test mass.

13.1.3.4 Gravity Recovery

The optimum single pass table gold recovery for the sample at 100% passing 1.18 mm was 56.2% into 15% of the feed mass at a grade of 4.2 g/t Au. The table tails grade was 0.58 g/t, therefore gravity recovery methods were employed in order to minimize the loss of gold to tails.

A Falcon batch centrifugal concentration was used on the gravity tails and selected gravity concentrates 3, 4 and 5, to increase the recovery of gold into a smaller mass. The Falcon was able to recover 22.1% of the gold into 0.5% of the feed mass at a grade of 30.8 g/t Au. While the concentration of the ore via Falcon is considered low on its own, its contribution to overall gold recovery via gravity is significant.

13.1.3.5 Flotation

Coarse flotation completed on the Falcon tails at $P_{100} = 600 \mu\text{m}$ recovered 51.1% of the gold into 7.8% of the feed mass for a grade of 2.49 g/t Au. Whilst flotation completed on the Falcon tails that was ground to $P_{100} = 125 \mu\text{m}$ recovered 57.1% of the gold into 11.8% of the feed mass achieved a grade of 2.27 g/t Au. The tails grade for both the coarse and fine flotation tails were consistent with one another, at 0.20 g/t Au and 0.23 g/t Au respectively.

13.1.3.6 Cyanidation

Intensive cyanidation tests were carried out on the combined gravity and flotation tests to determine leach amenability.

13.1.3.7 Total Gold Recovery (Table, Falcon, Flotation, Cyanidation)

The recovery of gold for combined table, Falcon and coarse flotation concentrate was 82.7% at a grade of 8.20 g/t into 10.5% of the feed mass whilst the overall gold recovery of combined table, Falcon and fine flotation concentrates of 82.6%, at a grade of 6.45 g/t into 14.4% of the feed mass.

Combined gravity, Falcon and fine flotation concentrate (LGOLD 02) displayed higher recoveries. Over 24 hours gold leach recovery for LGOLD 01 was 74.2% and over the same time period, gold leach recovery for LGOLD 02 was 90%.

13.1.4 UNITÉ DE RECHERCHE ET DE SERVICE EN TECHNOLOGIE MINÉRALE (URSTM)

Project №: PU-2013-09-835-B

This report presents results of selected metallurgical tests done on Granada ore. These tests have been done from September to October 2013 by Jean Lelièvre, P. Eng., M.Sc., from URSTM, in the mineral processing facilities of *Cégep de l'Abitibi-Témiscamingue* in Rouyn-Noranda (QC) Canada. The fire assays and ICP on solids were conducted at Laboratoire Expert, Rouyn-Noranda (QC). Cyanide analyses

were done by Multilab at Rouyn-Noranda. Acid generating tests (ABA and NAG) were performed by Mr. Marc Paquin, chemist at URSTM.

13.1.4.1 Head Analysis

Head analysis for the gold and silver returned the following values:

Table 13-4: Head analysis results

Samples	Au	Au-Dup	Ag	Ag-Dup
	g/t	g/t	g/t	g/t
S-1	0.72	0.69	0.6	0.5
S-2	0.69		0.2	
S-3	0.62	0.62	0.4	0.4
S-4	0.69			
S-5	1.37			
S-6	1.44			
S-7	0.62			
S-8	0.55			
Average	0.81		0.42	

13.1.4.2 ICP analysis in head sample

Table 13-5: ICP analysis in head sample results

Granada Ore Sample	Concentration								
	Ag	As	Cu	Fe	Ni	Pb	Sb	S	Zn
	ppm	ppm	%	%	ppm	ppm	ppm	%	ppm
	1.30	105.0	>1.0	6.53	148.0	14.0	<10	1.60	54.0

13.1.4.3 Acid Generating Tests

The acid generating test returned the following results:

Table 13-6: Acid generating tests results

Granada Ore Sample	S _t	S _{sulphate}	S _{sulfur}	AP	C _t	NP	NNP	NP/AP	Potential Acid Producing
	%	%	%	CaCO ₃	%	CaCO ₃	CaCO ₃		
				k/t		kg/t	kg/t		
	1.28	0.047	1.23	38.4	1.50	65.2	26.8	1.7	Yes

13.1.4.4 Ore Specific Gravity

Specific gravity of each sample has been evaluated by the pycnometer method and was found to be 2.78.

13.1.4.5 Ball Mill Work Index:

A Bond ball mill work index has been done on the Granada ore using the standard work index protocol. The ball mill work index of Granada sample was 10.9 kW-h/tonne. A work index of 10.9 is a very low figure compared to most Canadian gold ores.

13.1.4.6 Gravity-Cyanidation Tests

A combined gravimetric concentration and cyanidation - carbon adsorption of gravimetric tails has been performed on the Granada samples. Results are summarized in the following Table 13-7:

Table 13-7: Gravity cyanidation test results

	Mass	Mass	Grade	Distribution
	g	%	g/t	%
Grav. conc.	1.39	0.03	2265.0	41.0
Carbon ads.	110.7		38.5	55.5
Solution	8213.3		0.015	1.6
Tails solid	4789.6	99.97	0.03	1.9
Calc. feed	4791.0	100	1.60	100

Overall gold recovery: 96.5%

Free gold (gravity recovery): 41.0%

13.1.4.7 Chemical consumption

NaCN : 0.25 kg/t

Ca(OH)₂ : 1.74 kg/t

13.1.4.8 Settling Tests (Thickener dimensioning)

A total of three (3) laboratory settling tests have been done on cyanided Knelson-Mozley tails and the Talmage and Fitch method has been used for estimating the thickening area (m²/tpd). Results are summarized in the following Table 13-8:

Table 13-8: Settling tests results

Test	Flocculent Dosage Percol E10	% solid initial	% solid final	Thickener Unit area m ² /tpd	Supernatant clarity
SED-1	0.0 g/t	23.2	55.0	0.138	Poor
SED-2	4.6 g/t	23.2	55.0	0.046	Clear
SED-3	18.4 g/t	23.2	55.0	0.041	Clear

13.1.4.9 Cyanide Destruction Tests

A total of (4) cyanide destruction has been done on cyanided tailings of the Granada ore. The cyanide destruction method used was the SO₂-Air method. As usual for lab testing, the SO₂ was substituted by sodium metabisulfite (Na₂S₂O₅).

Principal parameters as well as cyanide destruction results are given in the following table:

Table 13-9: Cyanide destruction test results

Test	Description		Ret. time hours	Reagents addition			pH	CNd	CNT	As	Cu
				Na ₂ S ₂ O ₅ kg/t	CuSO ₄ .5H ₂ O kg/t	Ca(OH) ₂ kg/t					
1	pH 8.5 SO ₂ /CNd 6.73 0 ppm Cu addition	Before CN dest.						267	264	0.33	25.44
		After CN dest.	2	4.18	0.0	1.58	85	0.05	0.16	0.21	2.56
2	pH 8.5 SO ₂ /CNd 6.73 103 ppm Cu addition	Before CN dest.						267	264	0.33	25.44
		After CN dest.	2	4.18	0.6	1.49	8.5	0.06	0.63	0.08	0.19
3	pH 8.5 SO ₂ /CNd 5.17 26 ppm Cu addition	Before CN dest.						267	264	0.33	25.44
		After CN dest.	2	3.21	0.2	0.83	8.5	21.58	25.29	0.11	26.63
4	pH 8.5 SO ₂ /9.07 130 ppm Cu addition	Before CN dest.						267	264	0.33	25.44
		After CN dest.	2	5.63	0.8	2.00	8.5	0.12	0.43	0.08	0.19

13.1.4.10 Gravity-cyanidation duplicata

Out of the 23.5 kg of sample received by the URSTM, some 19.4 kg was used for the above tests thus leaving approximately 6.1 kg untouched. Because of the problem of conciliating the ore geological and mining grades to the tests head grades, probably due to a bad nugget effect, the URSTM was asked to do another gravity-cyanidation test employing the rest of the sample.

Same protocol as the one used at Article 13.4.5 above was employed. Results are summarized in the following table:

Table 13-10: Gravity Cyanidation duplicate results

	Mass	Mass	Grade	Distribution
	g	%	g/t	%
Grav. conc.	4.44	0.07	616.0	15.1
Carbon ads.	154.1		96.0	81.7
Solution	10269.8		0.015	0.8
Tails solid	6107.6	99.93	0.07	2.4
Calc. feed	6112.0	100.0	2.97	100.0

Overall gold recovery:	96.8%
Free gold (gravity recovery):	15.1%
NaCN consumption =	0.18 kg NaCN / mt of ore
Ca(OH) ₂ consumption =	1.97 kg Ca(OH) ₂ / mt of ore

13.2 DISCLAIMER

No metallurgical testwork was carried out by SGS Geostat, nor were they supervised by the QP responsible for the Mineral Processing and Metallurgical Testwork section of this report. As such, the results were not independently verified, but are believed to be of sound quality.

14 Mineral Resource Estimates

The mineral resource estimates are derived from a computerized resource block model. The construction of that model starts with drillhole data, which serves as the basis for the definition of 3D mineralized envelopes in which resources are limited to the material inside those envelopes. The next step is the selection of drillhole data within the mineralized envelopes in the form of fixed length composites and then the interpolation of the grade of blocks on a regular grid and filling the mineralized envelopes from the grade of the composites in the same envelopes. All the interpolated blocks between the overburden/bedrock contact and the pit bottom surface make the in-pit mineral resource (see Reserves section, no dilution or mining loss shown in this section).

It was not possible to model the historical mined out area. Historical drillhole data was integrated but not used for the resource estimates. The limited historical production has to be removed from the resource statement.

A resource model for the Rolling Start Project and a resource model for mining underground are presented in the following section.

14.1 RESOURCE MODEL FOR THE ROLLING START PROJECT

14.1.1 DRILLHOLE AND SAMPLE DATA

Data used in the 2013 resource estimate was taken from a previous SGS assignment in which data was provided by Gold Bullion Development Corporation and validated by SGS employees. Four hundred and twenty-four (424) drillholes totaling 88,580 m of drill core and 62,387 analyses were exported from **GoldBullion_DB_January15_2013.accdb** for use in the resource estimation. The drillhole database includes data from 2009 to 2012; historical drillhole data was not used in the modeling or resource estimation with the exception of 1 hole from 1990 and 6 holes from 1994. These holes were included as drilling in the far north and west is sparse. The collar locations were confirmed, paper log copies exist on site, and resources around the historic holes are inferred only. Drillholes used in the estimation are presented in Figure 14-1 and all drillholes in the database (including historical holes) are presented in Figure 14-2 and Figure 14-3. Drillhole deviation data was recorded using various instruments totaling 6,787 measurements. Mineralized intervals generated by SGS were used to create envelopes respecting a horizontal mining width of 7-10 m. Envelopes were designed to contour mineralized structures therefore waste material was included. The 3D modeling and resource estimation were completed using Genesis, software designed and owned by SGS.

14.1.1.1 Topography

The topography at the time of this resource estimation had been surveyed using Lidar. The majority of drillhole collars were resurveyed using a DGPS system with centimetre accuracy and are considered to be reliable. Overburden lithologic units within the drillhole logs were used to generate a surface from which the resource block model was limited. Underground drifts and shafts in 3D were provided by Richard Laprairie in a DXF file format.

14.1.1.2 Density

Historical densities used by Metchem Pellemon range from 2.91 to 3.1 g/m³. Independent density measurements taken by SGS range from 2.68 to 2.9 g/m³ with a mean of 2.8 g/m³. Additional measurements taken in 2012 have lowered the average to 2.7 g/m³. It is thought that the density is related to rock type and alteration. The Author recommends additional SG measurements on the various

sectors to examine if variable density should be used. A density of 2.7 g/m³ was used based on historical measurements used by Metchem Pellemon and additional measurements taken by SGS in 2012.

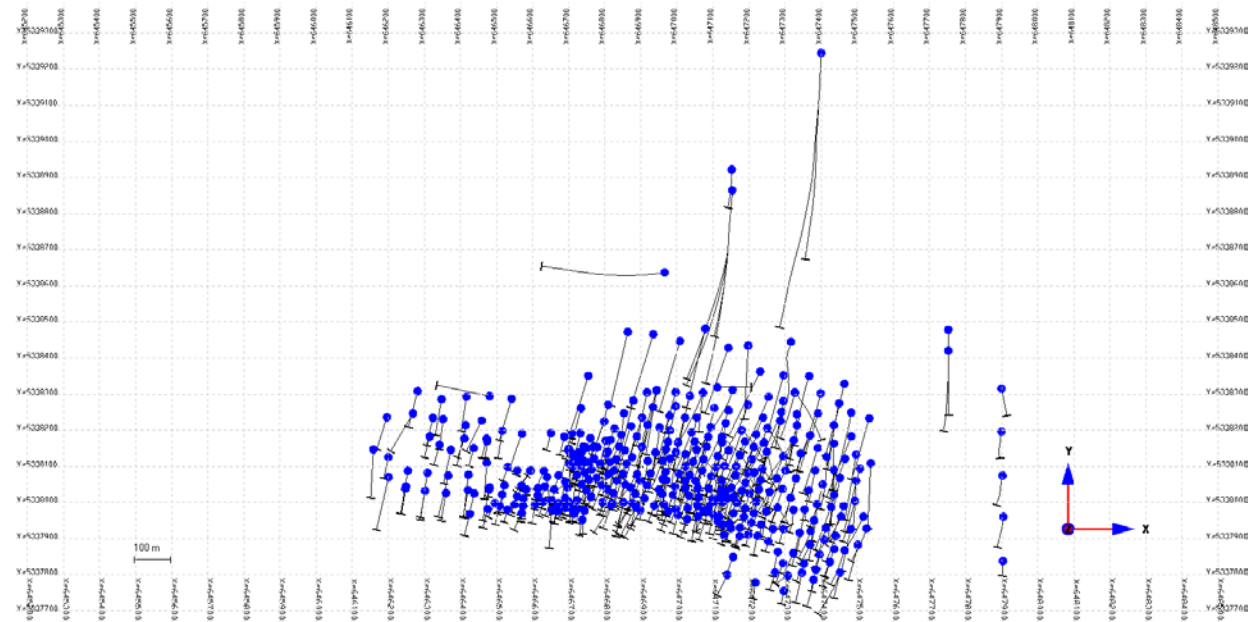

Figure 14-1: Drillhole Locations and Traces used in the resource estimation

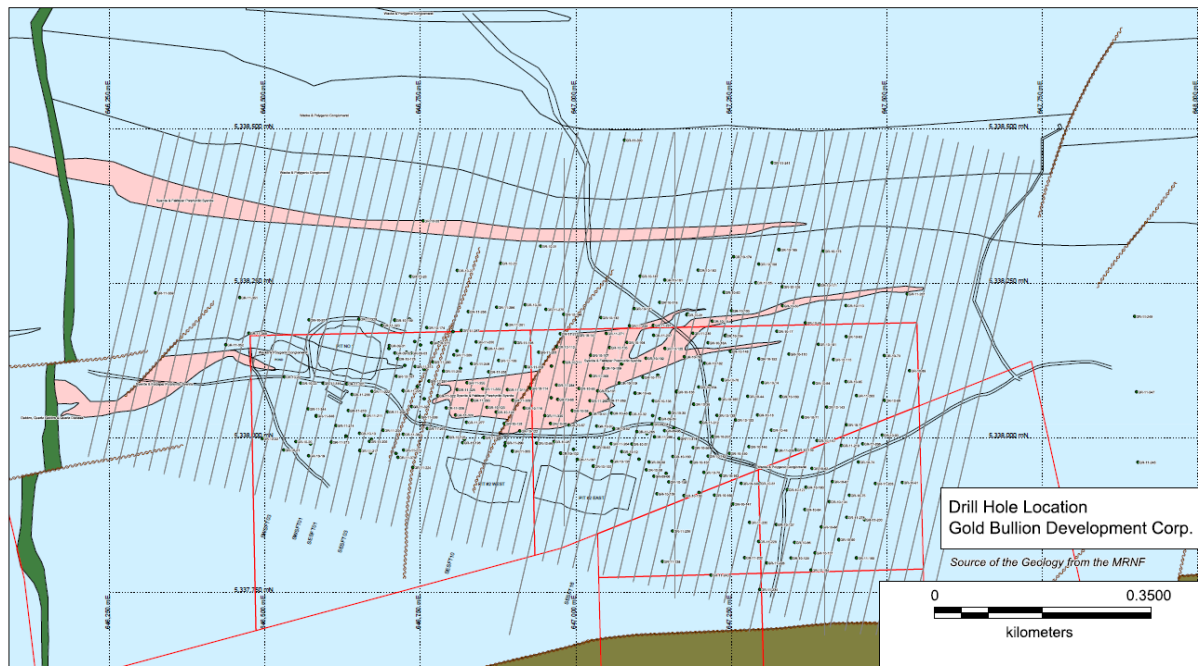

Figure 14-2: Drillhole phase 1 to 3 with cross section layout and property

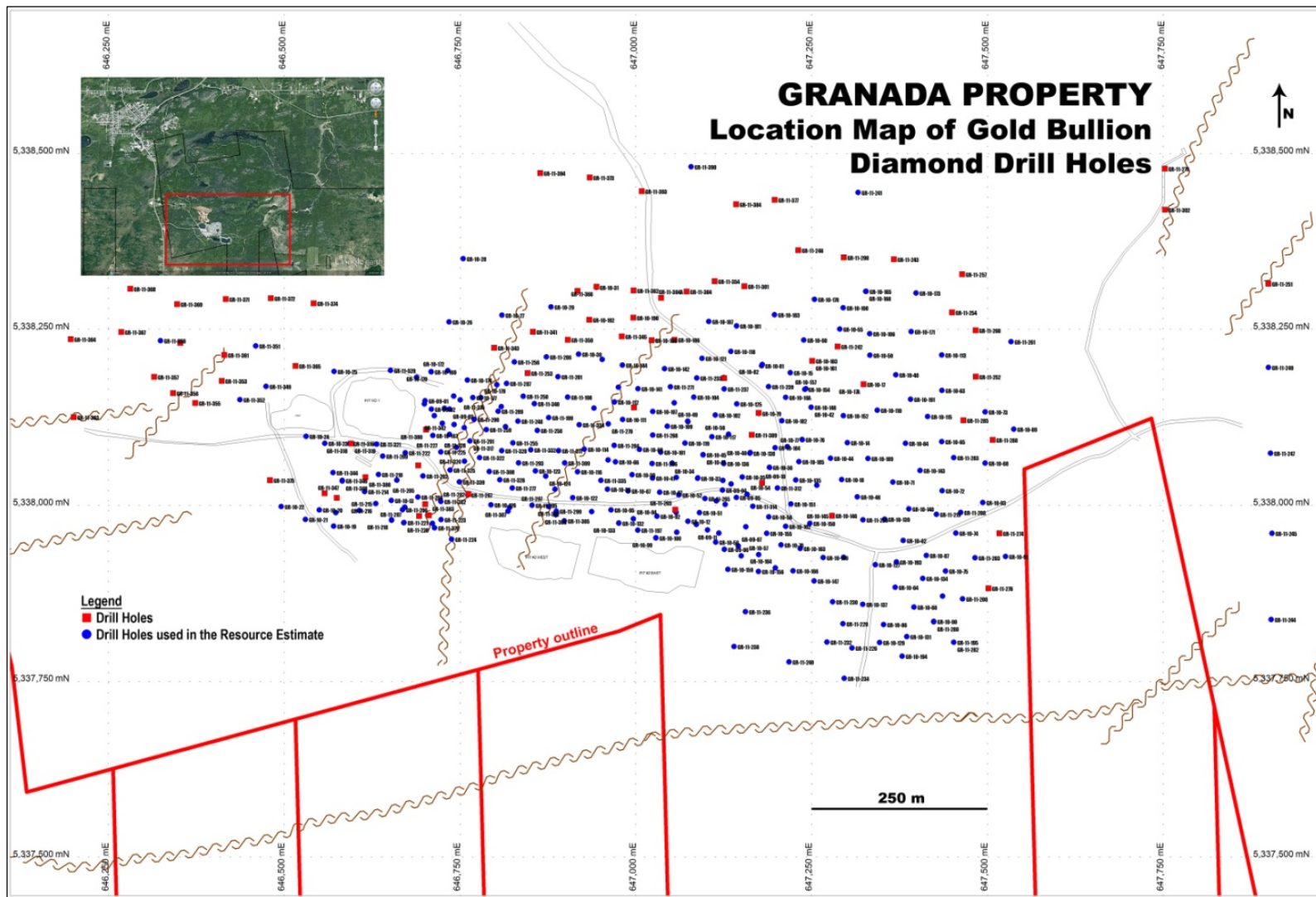

Figure 14-3: All drillhole locations and property extent

14.1.2 GEOLOGICAL AND BLOCK MODELING

14.1.2.1 Overview

This resource estimate presents an alternative to the estimate of February 2013. High-grade structures were modelled individually as opposed to the previous bulk mineralization resource. No new drillhole or analytical data was added to generate this selective mining scenario.

The mineral resource was estimated by Claude Duplessis, Eng., consulting Geological Engineer for SGS Canada Inc., with the assistance of Amanda Landriault, Geologist of SGS Canada Inc. Mr. Duplessis is an independent qualified person (QP) as per section 1.4 of the NI 43-101 Standards of Disclosure for Mineral Projects.

14.1.2.2 Modelling

Cross sectional views oriented NNE looking WNW and 25 m apart were used to study mineralization patterns and group assays into mineralized intervals. Prisms were created by snapping to the mineralized intervals, which were diluted to respect a minimum mining width of 7 to 10 m. A cut-off grade of 0.5 g/t was considered while modeling however, waste was included for structure continuity. Mineralized solids were generated based on the linked prisms and faults were designed based on historical records of fault intersections in underground workings and historic geologic plan maps (Figure 14-4). The faults are discussed in further detail in section 7 – Geological Setting. A Boolean solid consisting of all the mineralized solids was generated. Equal-length composites of 1 m were produced from the mineralized intervals and were capped at 30 g/t.

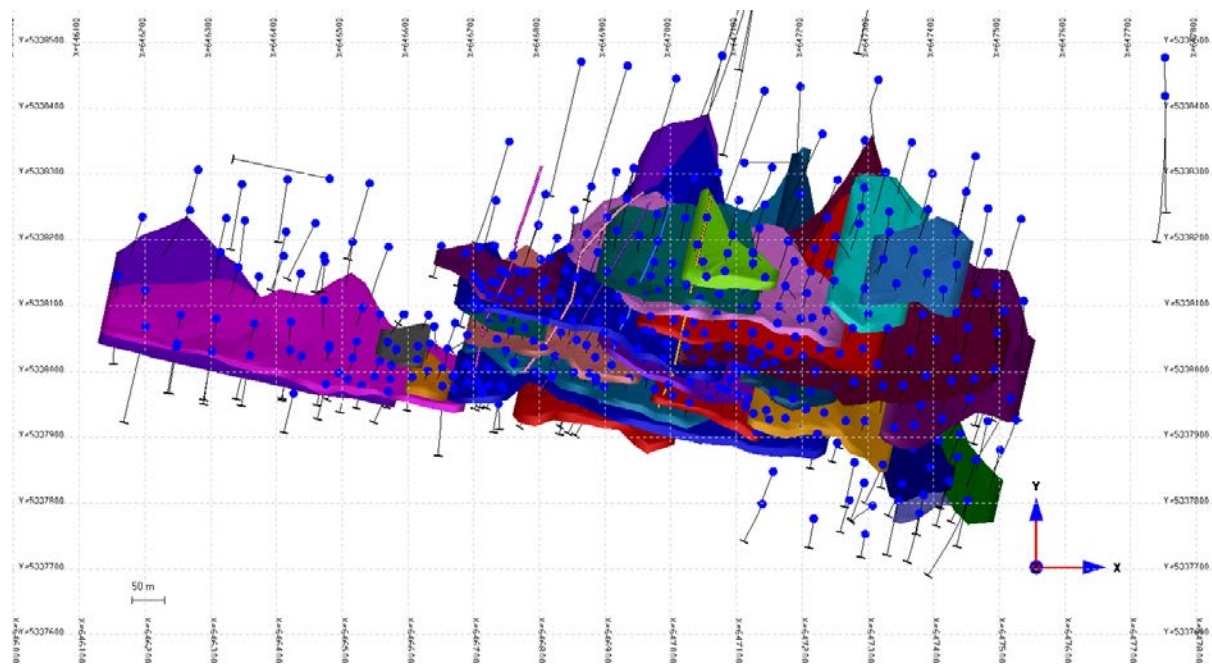

Figure 14-4: Plan view of the mineralized solids including NNE-trending, sub-vertical faults

The material within the resource model is discretized with the blocks of 5m (E-W) by 2.5m (N-S) by 5m (Vert.). The 5m vertical side corresponds to the bench height of the future open-pit operation. The 5m E-W dimension corresponds to about quarter the minimum spacing between GBB surface holes. The 2.5m N-S dimension accounts for the perceived greater grade variability along that direction. With fixed density of 2.7 t/m³, each full block (5mx2.5mx5m) represents about 168.75 tonnes and it is assumed reasonable for the selective mining unit (SMU) or minimum size block which can be selectively extracted as ore or waste in a future potential open-pit operation.

The block model grid extends from UTM 646,000E to 647,800E and 5,337,600N to 5,339,100N from 325 m to -800 m above sea level, where site surface elevation is approximately 320m.

14.1.2.3 Compositing, statistical analysis and capping

Since original assay intervals did not have the same lengths, composites were created to standardize that length. The grades of these fixed length intervals were used in the interpolation of the average grade of nearby 5x2.5x5 m blocks. This exercise was done with 1 m down-hole composites. This composite size was selected as the uniform length which best matched most of the original samples and the 5 m N-S thickness of the 5x2.5x5 m resource blocks to be interpolated. By selecting a composite with a smaller length to that of mineralized block intercepts, we have to increase the number of composites in the estimation to warrant that the grade dilution originating from the block size will be included in the grade of samples used to interpolate the grade of blocks.

Most gold values in the drillhole assay intervals are low grade however there are a few individuals with extremely high values which require capping before those gold values are used in block grade interpolation. A standard approach to high grade capping consists of examining the high end of gold distributions in search for any natural gap in those distributions.

14.1.2.3.1 Capping

A capping study was performed on the composite data. A discontinuity is apparent in Figure 14-5 at high grade values of 30 g/t, as well as 40 g/t. The values were capped at 30 g/t to be conservative but 40 g/t could be considered in future after further exploration.

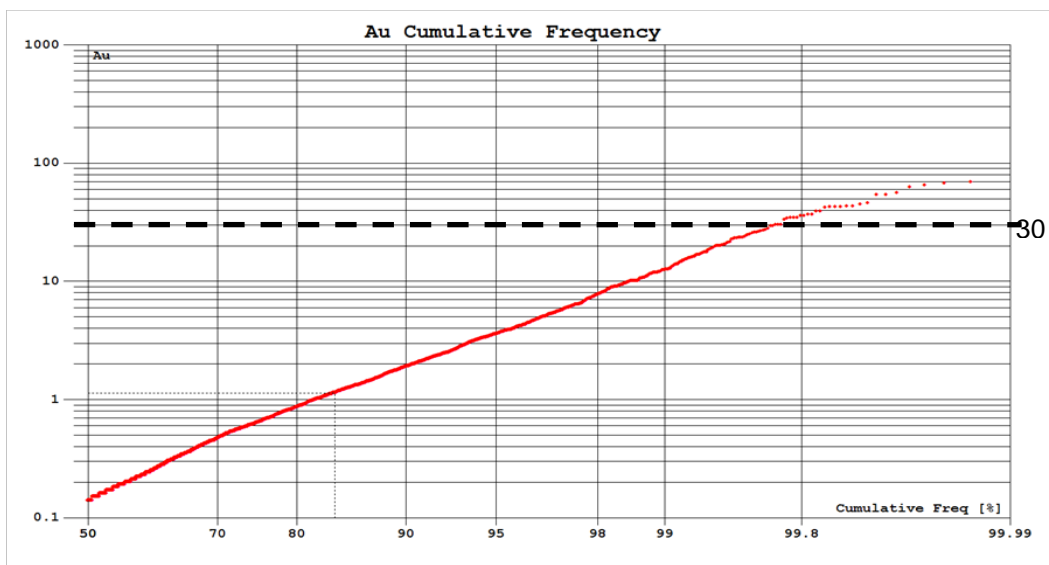

Figure 14-5: Cumulative Frequency diagram Au g/t of the 1 m composites

14.1.3 BLOCK GRADE INTERPOLATION

14.1.3.1 Variography

Although the inverse distance squared method was used to estimate the block model, a variography study was performed to confirm respectable search ellipsoid parameters. Figure 14-6 displays the variography results on 1 m composites capped at 30 g/t. The results confirm the search ellipsoid parameters of the “Down Dip” oriented ellipse remain the strongest. The nugget effect and the range are approximately 28 % and 65 m respectively.



Figure 14-6: Variogram of 1 m Au composites Log capped at 30 g/t

14.1.3.2 Estimation parameters

The 1 m composites were restricted to the limits of the Boolean solid and a block model of 5 x 2.5 x 5 m was generated. The resource estimate was calculated using the inverse distance squared method and two passes of disc ellipses, oriented down-dip as supported by the variographic analysis. Figure 14-7 displays the block model generated. Table 14-1 outlines the estimation parameters.

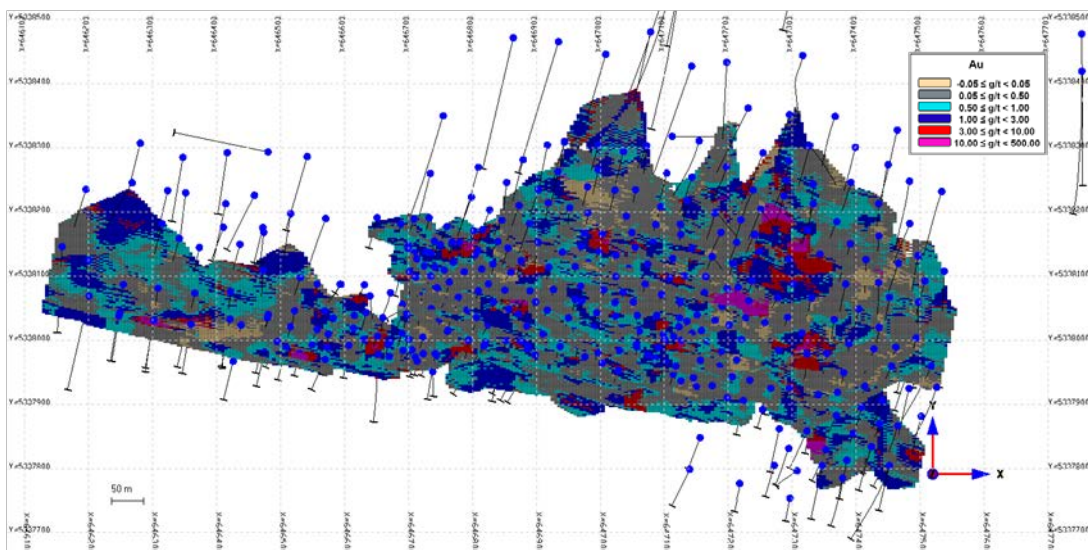

Figure 14-7: Plan view of the block model cut to overburden surface

Table 14-1: Block model parameters

Pass	Azimuth	Dip	Spin	X (m)	Y (m)	Z (m)	Minimum Samples per Block	Maximum Samples per Block	Minimum Drillholes
1	10	-45	5	100	75	7	3	8	2
2	10	-45	5	150	100	10	2	8	1

Figure 14-8 and Figure 14-9 display the ellipsoid used for pass 2 in the block model estimation. The primary ellipsoid axis was oriented down dip and an attempt was made to align the secondary axis (azimuth) along the strike of the mineralized solids to reduce the risk of populating blocks with composites of neighbouring mineralized solids.

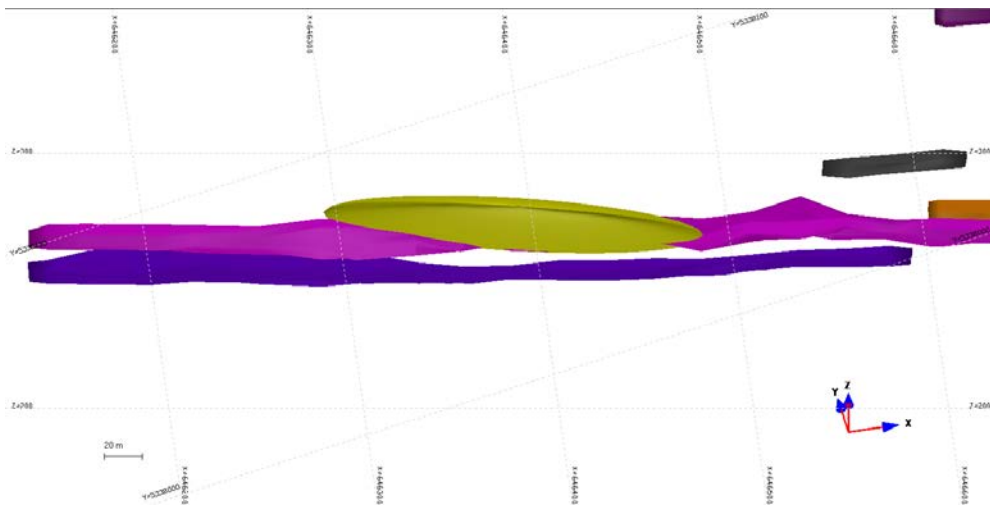

Figure 14-8: Ellipsoid for pass 2 of block model estimation. View looking down dip

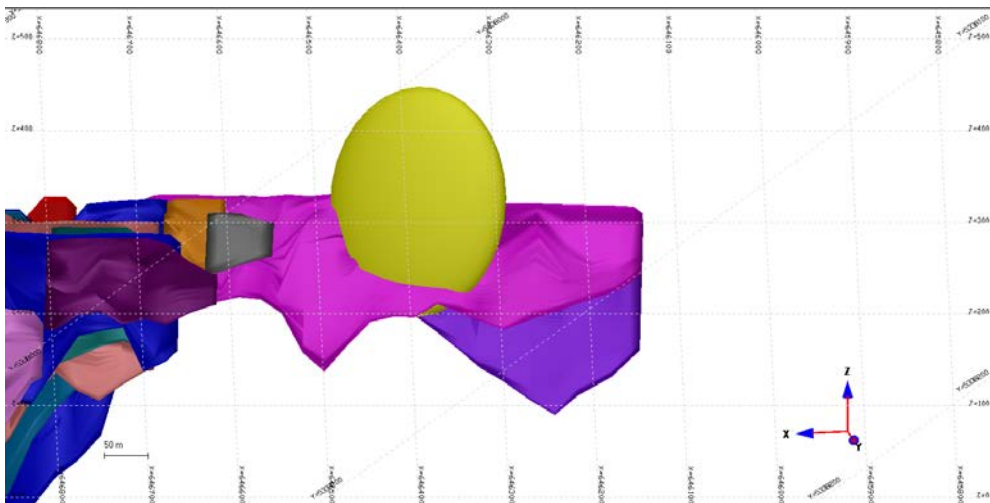

Figure 14-9: Ellipse for pass 2 of block model estimation. View perpendicular to dip

14.1.4 RESOURCE CLASSIFICATION

In this study the block resources in any given block are classified in an automatic manner and are not adjusted manually.

The Granada Gold deposit was classified using three passes of disc ellipsoids. The parameters are outlined in Table 14-2.

Table 14-2: Classification parameters

Category	Azimuth	Dip	Spin	X, Y (m)	Z (m)	Minimum Samples per Block	Maximum Samples per Block	Minimum Drillholes
Measured	10	-45	5	40	5	12	14	4
Indicated	10	-45	5	80	10	9	14	3
Inferred	10	-45	5	120	15	6	14	2

As usual, the automatic classification has its drawbacks but in general reflects the level of confidence even if we observe “Swiss cheese” or “spotted dog” patterns with patches of measured alternating with patches of indicated or inferred resource categories.

Figure 14-10 to Figure 14-17 display the mineralized intervals and respective solids. The block model displayed is extracted using an optimized pit designed with Whittle software.

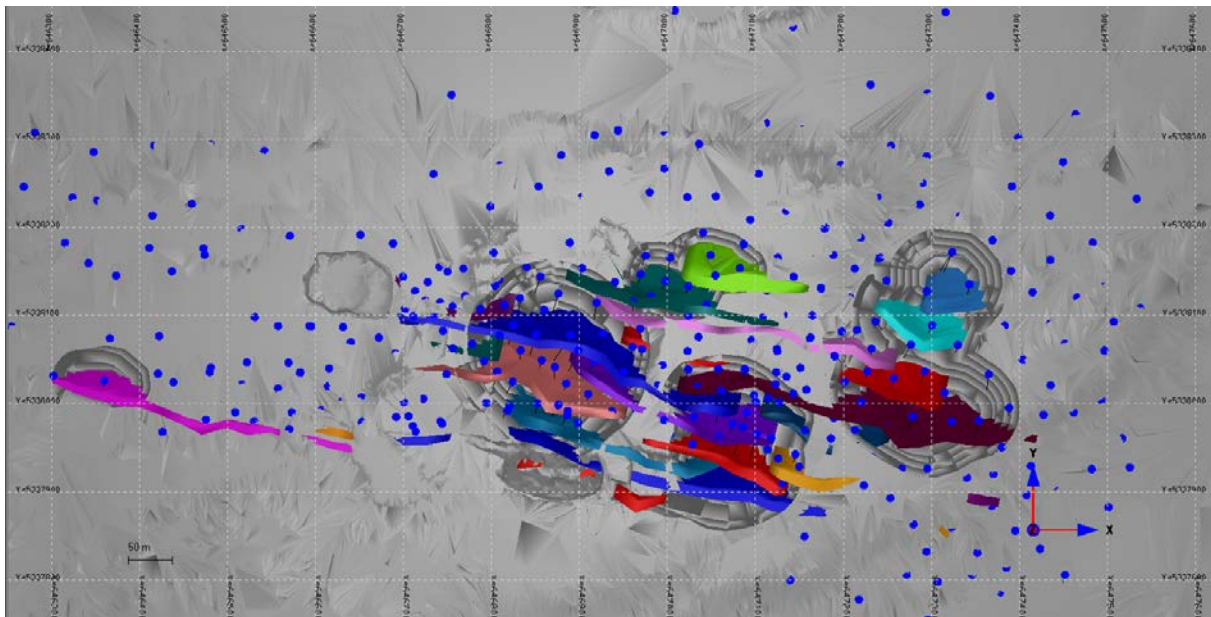

Figure 14-10: Plan view of the mineralized solids extracted above the optimized pit shell

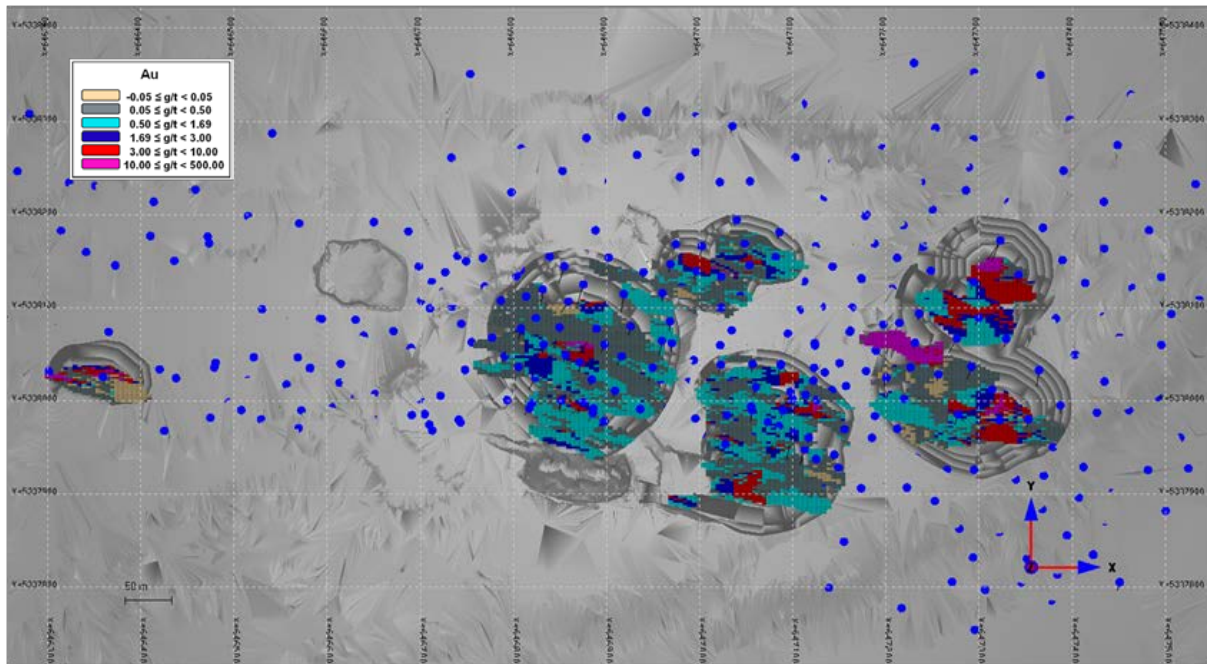

Figure 14-11: Plan view of the block model extracted above the optimized pit shell

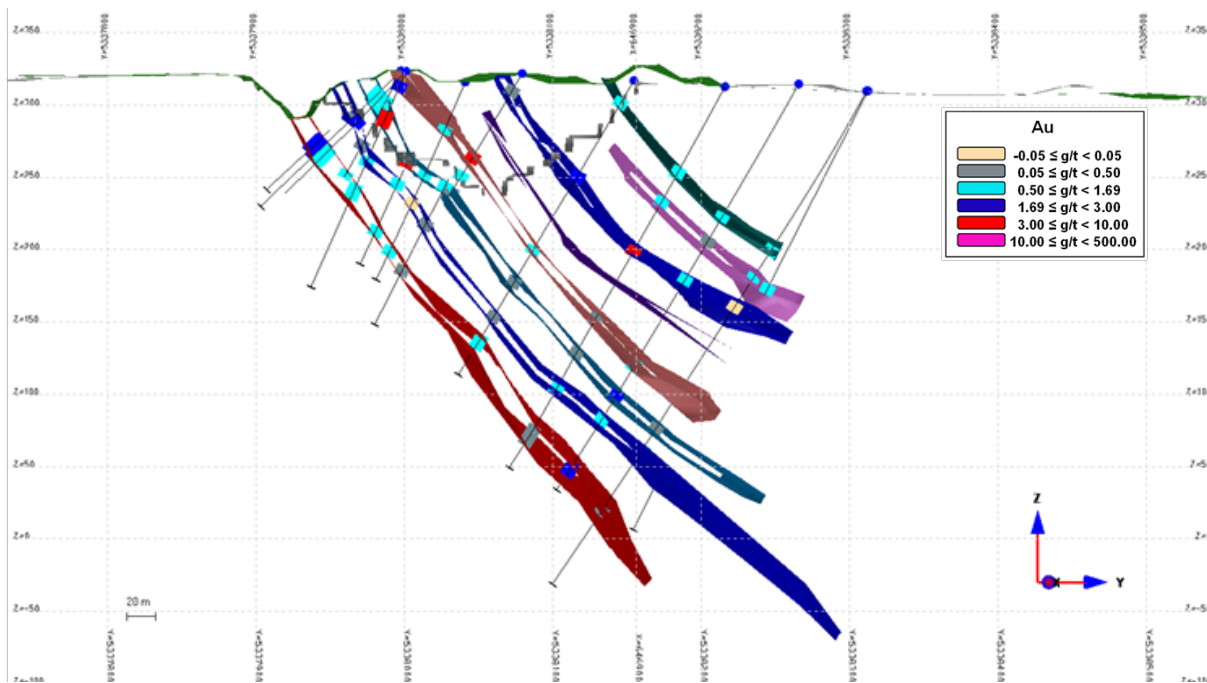

Figure 14-12: Mineralized intervals within their respective solids. Section 11 with a 25m viewing corridor looking WNW, azimuth of 283°

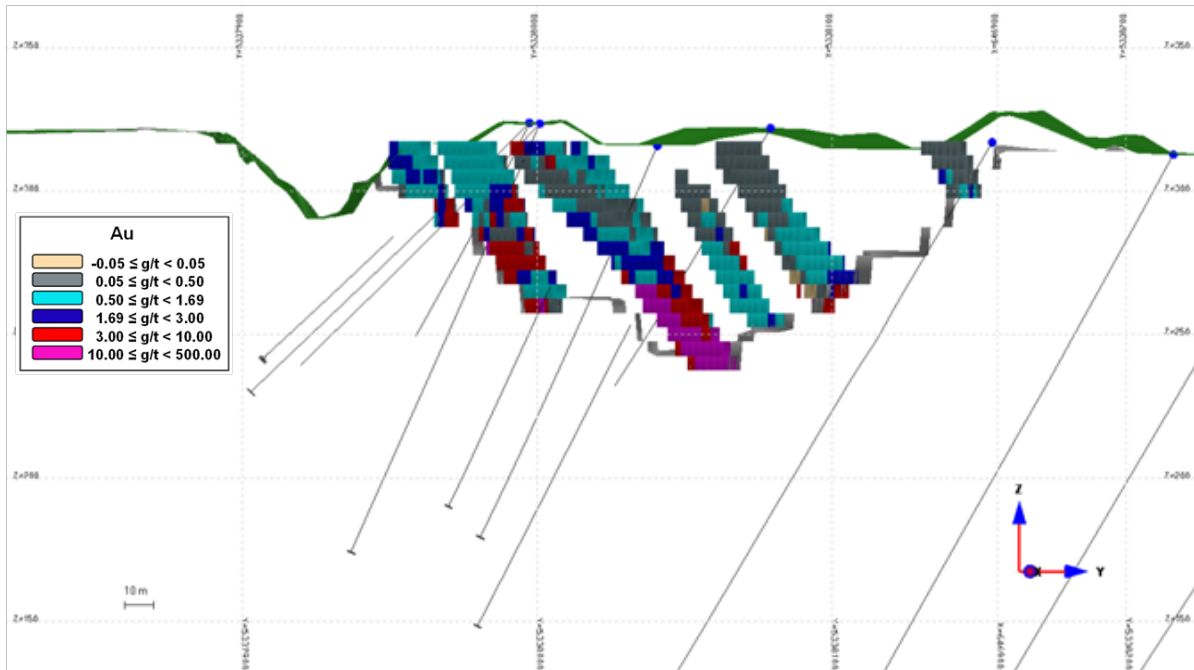

Figure 14-13: Au estimation of block model. Section 11 with a 25m viewing corridor looking WNW, azimuth of 283°

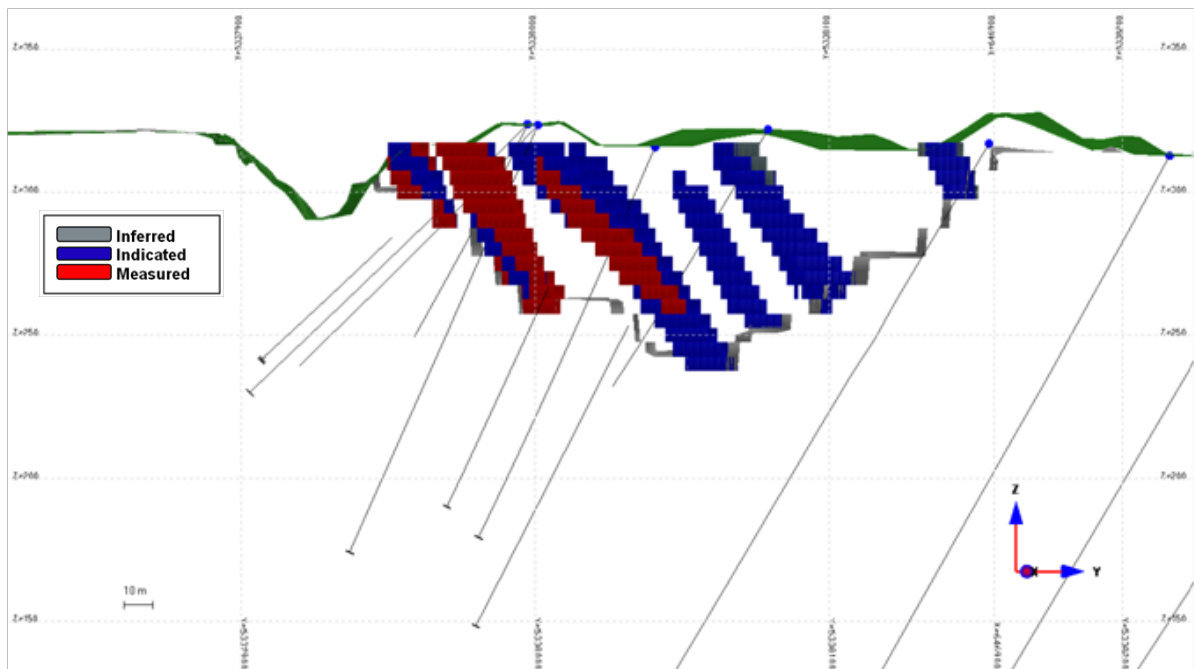

Figure 14-14: Classification of block model. Section 11 with a 25m viewing corridor looking WNW, azimuth of 283°

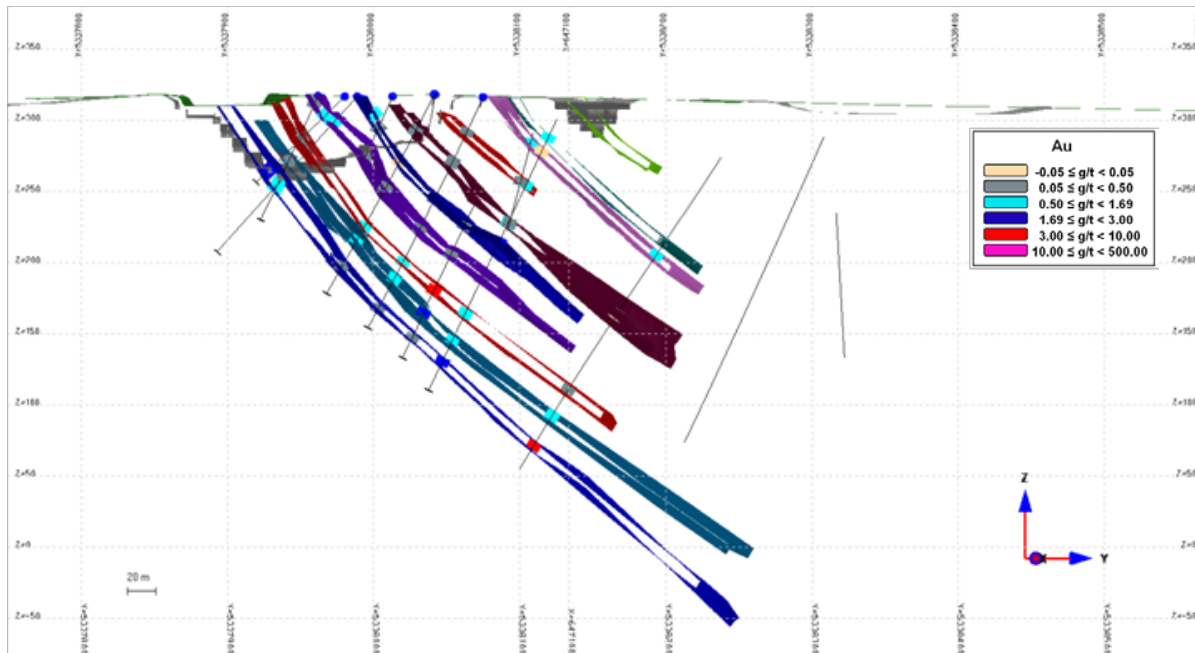

Figure 14-15: Mineralized intervals within their respective solids. Section 19 with a 25m viewing corridor looking WNW, azimuth of 283°

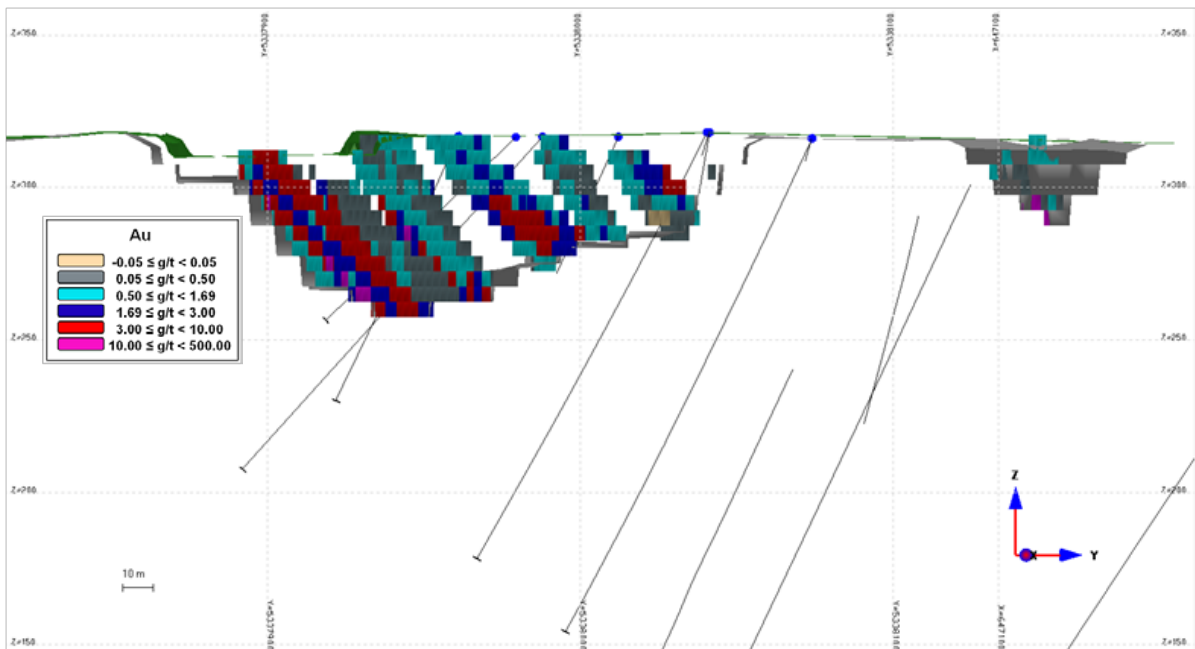

Figure 14-16: Au estimation of block model. Section 19 with a 25m viewing corridor looking WNW, azimuth of 283°

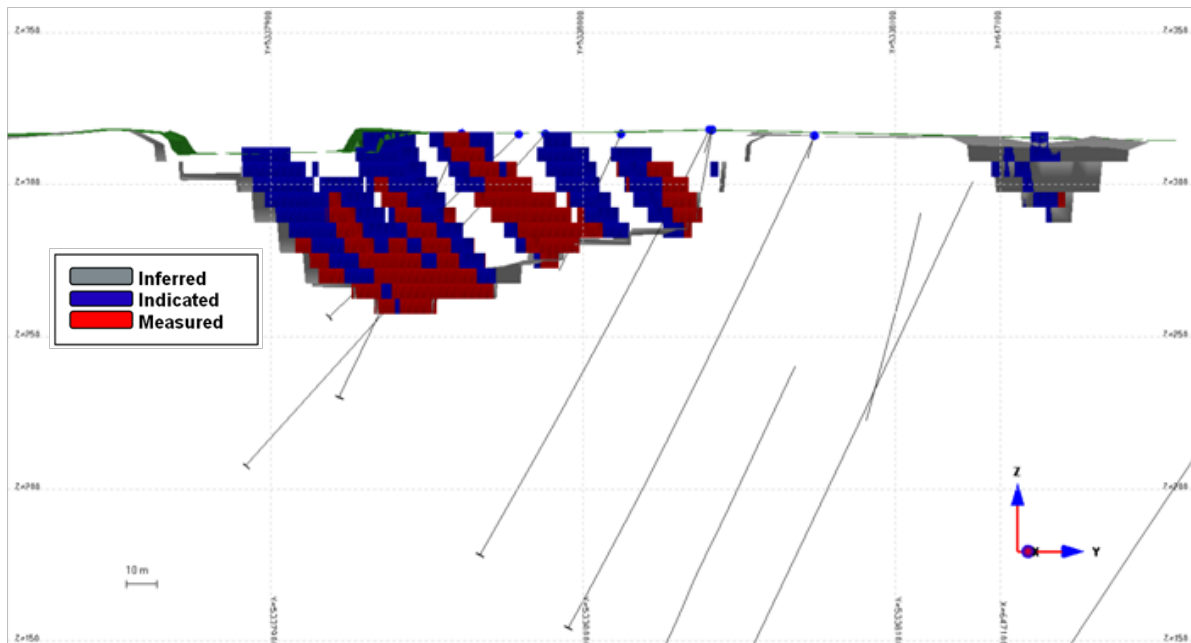

Figure 14-17: Classification of block model. Section 19 with a 25m viewing corridor looking WNW, azimuth of 283°

Figure 14-18 to Figure 14-21 display the resource estimation and classification for tonnage beneath the pit to the maximum depth of the pit, 237.5 m. This material cannot presently be considered when calculating the reserves however, should the price of gold increase, it has good potential if the pit were to expand.

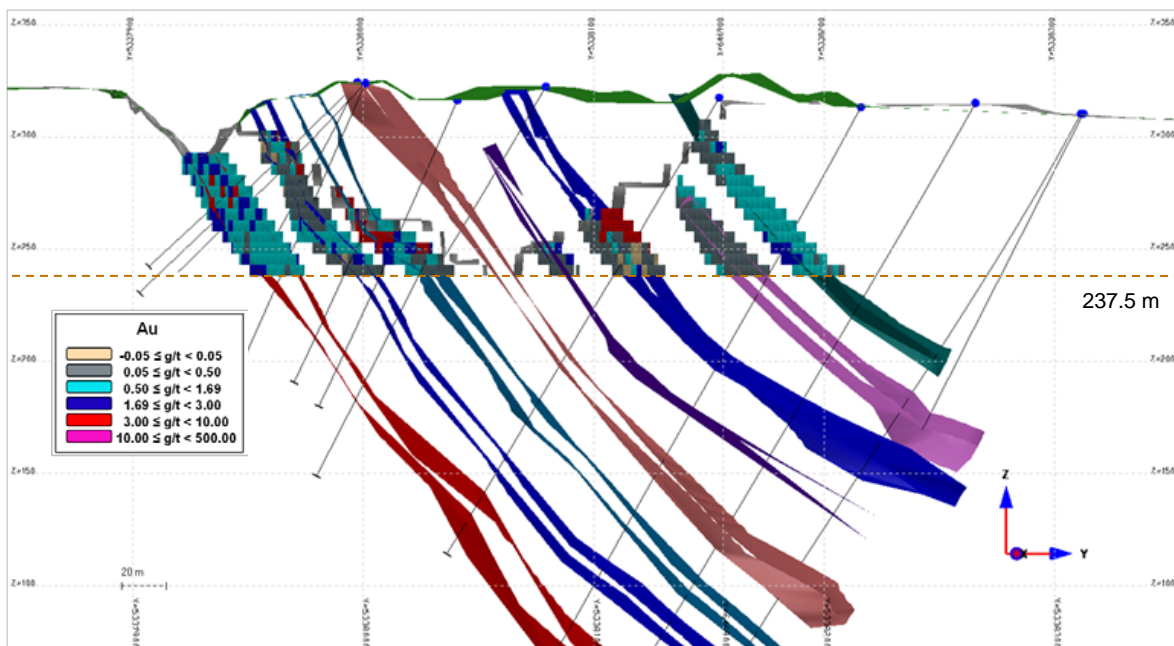

Figure 14-18: Estimation beneath the pit to 237.5m. Section 11 with a 25m viewing corridor looking WNW, azimuth of 283°

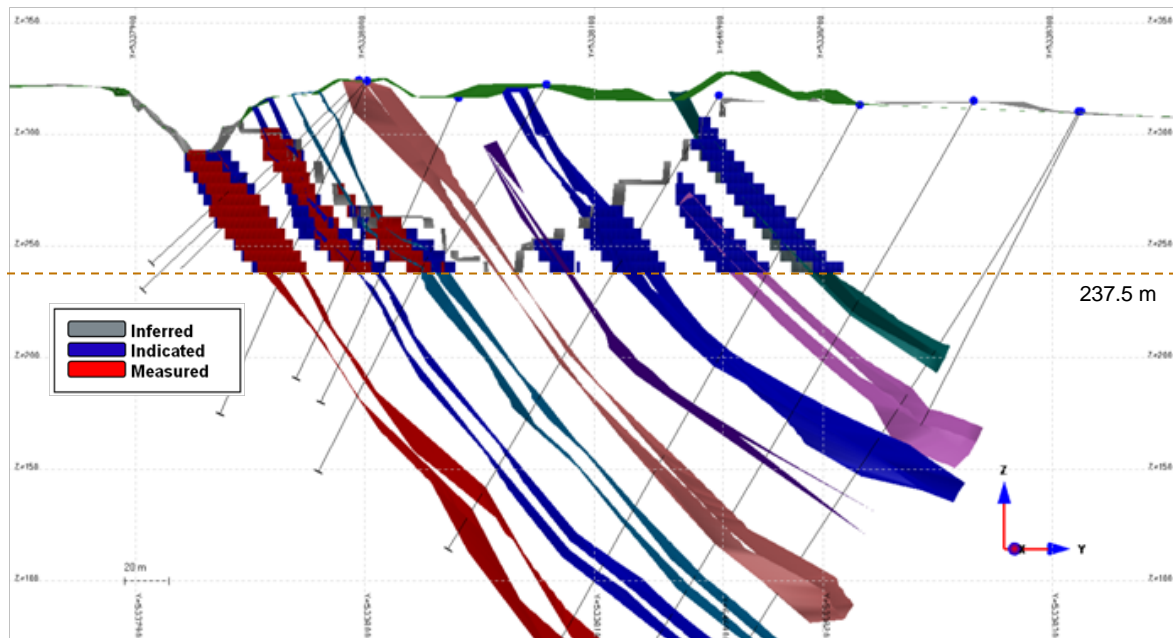

Figure 14-19: Classification beneath the pit to 237.5m. Section 11 with a 25m viewing corridor looking WNW, azimuth of 283°

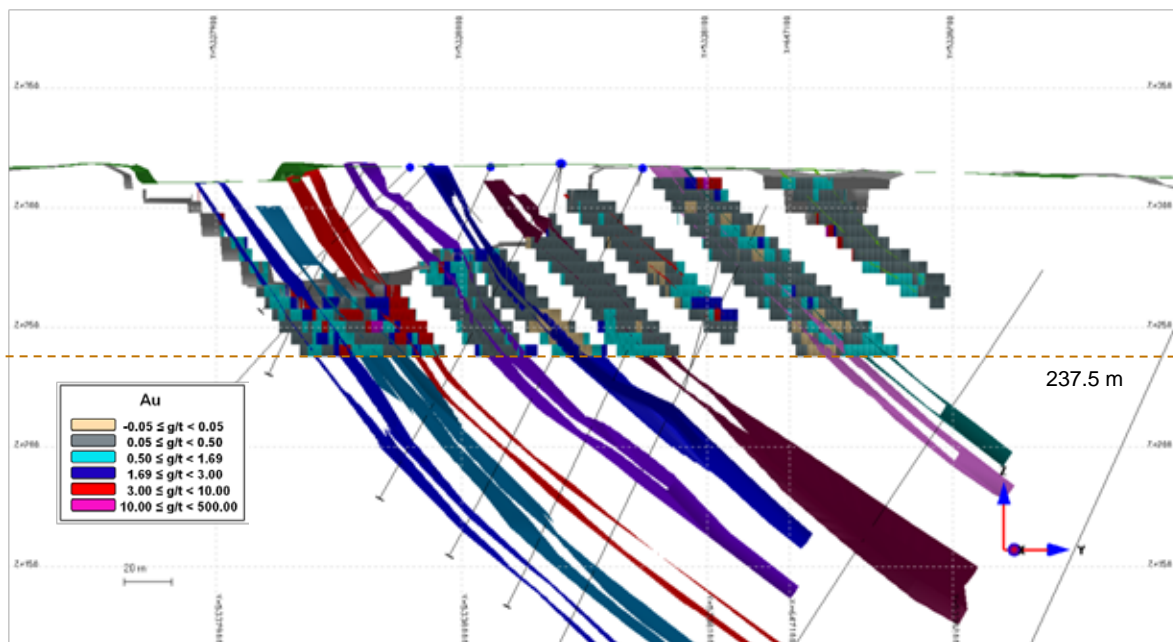

Figure 14-20: Estimation beneath the pit to 237.5m. Section 19 with a 25m viewing corridor looking WNW, azimuth of 283°

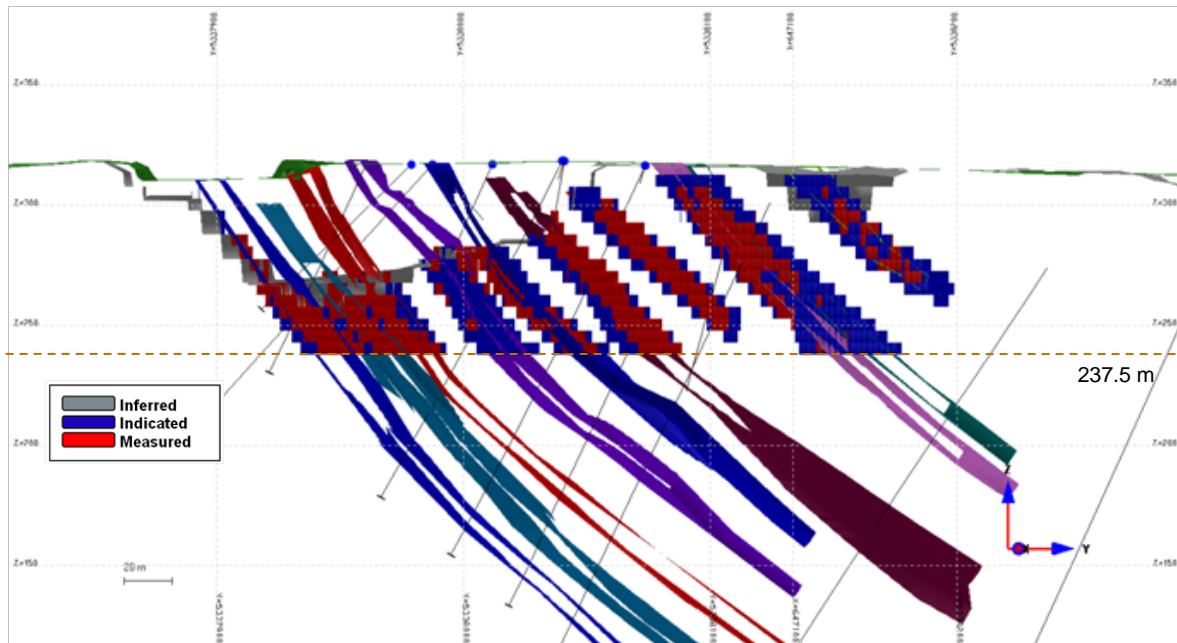

Figure 14-21: Classification beneath the pit to 237.5m. Section 19 with a 25m viewing corridor looking WNW, azimuth of 283°

14.2 UNDERGROUND RESOURCE MODEL

14.2.1 DRILLHOLE AND SAMPLE DATA

Data used in the 2013 resource estimate was taken from a previous SGS assignment in which data was provided by Gold Bullion Development Corporation and validated by SGS employees.

Between Jan 24 2014 and Feb 05 2014 Matthew Halliday GIT from SGS Geostat conducted further validation on the geological database. The database contained some overlapping assay data and as such informed decisions had to be made to better prepare and eliminate overlapping assays from entering block model. See section 12 – Data Verification for more details.

Four hundred and twenty-four (424) drillholes totaling 88,577 m of drill core and 62,375 analyses were exported from *GoldBullion_DB_Jan29_2014_MH_Fulledits.acddb* for use in the resource estimation. The drillhole database includes data from 2009 to 2012; historical drillhole data was not used in the modeling or resource estimation with the exception of 1 hole from 1990 and 6 holes from 1994. These holes were included as drilling in the far north and west is sparse. The collar locations were confirmed, paper log copies exist on site, and resources around the historic holes are inferred only. Drillhole deviation data was recorded using various instruments totaling 6,777 measurements.

Mineralized intervals generated by SGS were used to create envelopes respecting a horizontal mining width of 3-4 m. Envelopes were designed to contour mineralized structures therefore waste material was included. The 3D modeling and resource estimation were completed using Genesis, software designed and owned by SGS.

14.2.1.1 Topography

The topography at the time of this resource estimation had been surveyed using Lidar. The majority of drillhole collars were resurveyed using a DGPS system with centimetre accuracy and are considered to be

reliable. Overburden lithologic units within the drillhole logs were used to generate a surface from which the resource block model was limited. Underground drifts and shafts in 3D were provided by Richard Laprairie in a DXF file format.

14.2.1.2 Density

Historical densities used by Metchem Pellemon range from 2.91 to 3.1 g/m³. Independent density measurements taken by SGS range from 2.68 to 2.9 g/m³ with a mean of 2.8 g/m³. Additional measurements taken in 2012 have lowered the average to 2.7 g/m³. It is thought that the density is related to rock type and alteration. The Author recommends additional SG measurements on the various sectors to examine if variable density should be used. A density of 2.7 g/m³ was used based on historical measurements used by Metchem Pellemon and additional measurements taken by SGS in 2012.

14.2.2 GEOLOGICAL AND BLOCK MODELING

14.2.2.1 Overview

This resource estimate presents an alternative to the estimate of February 2013. Mineralized zones have been remodeled with 3 to 4 metres horizontal width below elevation of 237.5 m. High-grade structures were modelled individually as opposed to the previous bulk mineralization resource. No new drillhole or analytical data was added to generate this selective mining scenario.

The underground mineral resource was estimated by Claude Duplessis, Eng., consulting Geological Engineer for SGS Canada Inc., with the assistance of Lyne Maître, M. Sc. Env of SGS Canada Inc. Mr. Duplessis is an independent qualified person (QP) as per section 1.4 of the NI 43-101 Standards of Disclosure for Mineral Projects.

14.2.2.2 Modelling

Cross sectional views oriented NNE looking WNW and 25 m apart were used to study mineralization patterns and group assays into mineralized intervals. Prisms were created by snapping to the mineralized intervals, which were diluted to respect a minimum mining width of 3 to 4 m. A cut-off grade of 0.5 g/t was considered while modeling however, waste was included for structure continuity. Mineralized solids were generated based on the linked prisms and faults were designed based on historical records of fault intersections in underground workings and historic geologic plan maps (Figure 14-22). The faults are discussed in further detail in section 7 – Geological Setting. A Boolean solid consisting of all the mineralized solids was generated. Equal-length composites of 1 m were produced from the mineralized intervals and were capped at 30 g/t.

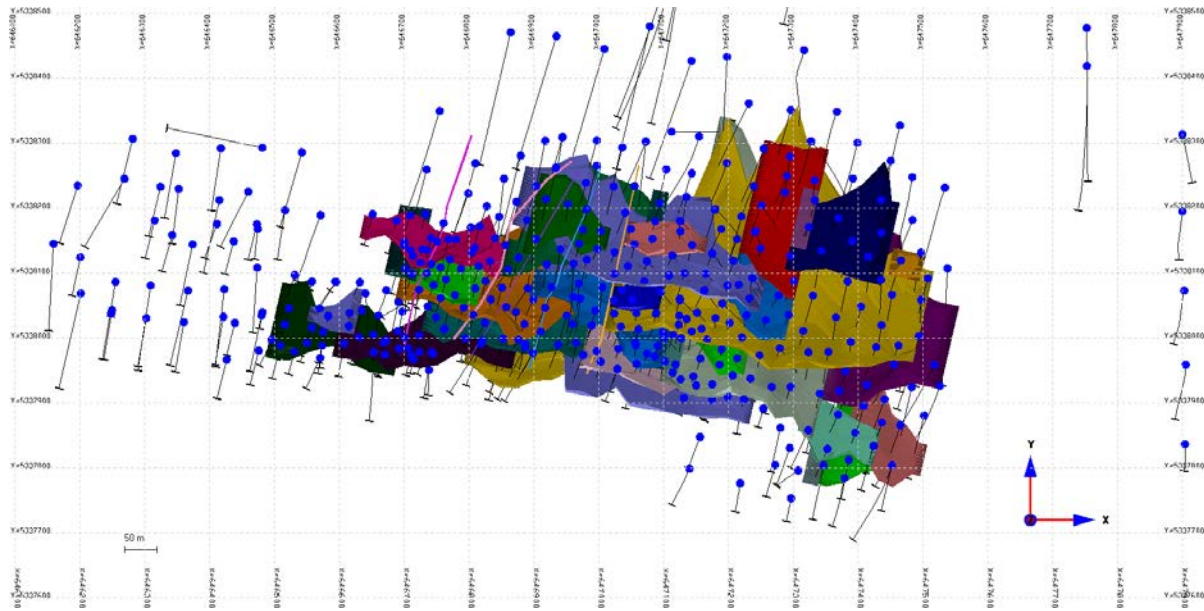

Figure 14-22: Plan view of the mineralized solids including NNE-trending, sub-vertical faults

The material within the resource model is discretized with the blocks of 2.5m (E-W) by 1.25m (N-S) by 1.25m (Vert.). The 1.25m N-S dimension accounts for the perceived greater grade variability along that direction. With fixed density of 2.7 t/m³, each full block (2.5mx1.25mx1.25m) represents about 10.55 tonnes and it is assumed reasonable for the selective mining unit (SMU) or minimum size block which can be selectively extracted as ore or waste in a future potential open-pit operation.

The block model grid extends from UTM 646,000E to 647,800E and 5,337,600N to 5,339,100N from 325 m to -800 m above sea level, where site surface elevation is approximately 320m.

14.2.3 COMPOSITING, STATISTICAL ANALYSIS AND CAPPING

Since original assay intervals did not have the same lengths, composites were created to standardize that length. The grades of these fixed length intervals were used in the interpolation of the average grade of nearby 2.5x1.25x1.25 m blocks. This exercise was done with 1 m down-hole composites. This composite size was selected as the uniform length which best matched most of the original samples and the 1.25 m N-S thickness of the 2.5x1.25x1.25 m resource blocks to be interpolated. By selecting a composite with a smaller length to that of mineralized block intercepts, we have to increase the number of composites in the estimation to warrant that the grade dilution originating from the block size will be included in the grade of samples used to interpolate the grade of blocks.

Most gold values in the drillhole assay intervals are low grade however there are a few individuals with extremely high values which require capping before those gold values are used in block grade interpolation. A standard approach to high grade capping consists of examining the high end of gold distributions in search for any natural gap in those distributions.

14.2.3.1 Capping

A capping study was performed on the composite data. A discontinuity is apparent in Figure 14-23 at high grade values of 30 g/t. The values were capped at 30 g/t.

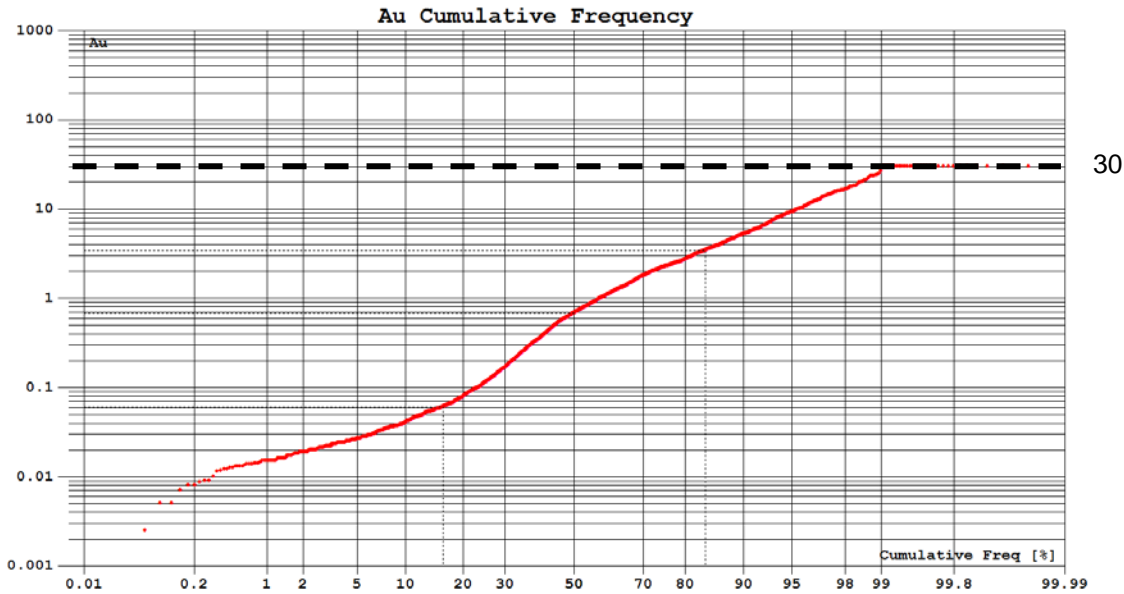

Figure 14-23: Cumulative Frequency diagram Au g/t of the 1 m composites

14.2.4 BLOCK GRADE INTERPOLATION

14.2.4.1 Variography

Although the inverse distance squared method was used to estimate the block model, a variography study was performed to confirm respectable search ellipsoid parameters. Figure 14-24 displays the variography results on 1 m composites capped at 30 g/t. The results confirm the search ellipsoid parameters of the “Down Dip” oriented ellipse remain the strongest. The nugget effect and the range are approximately 59 % and 90 m respectively.

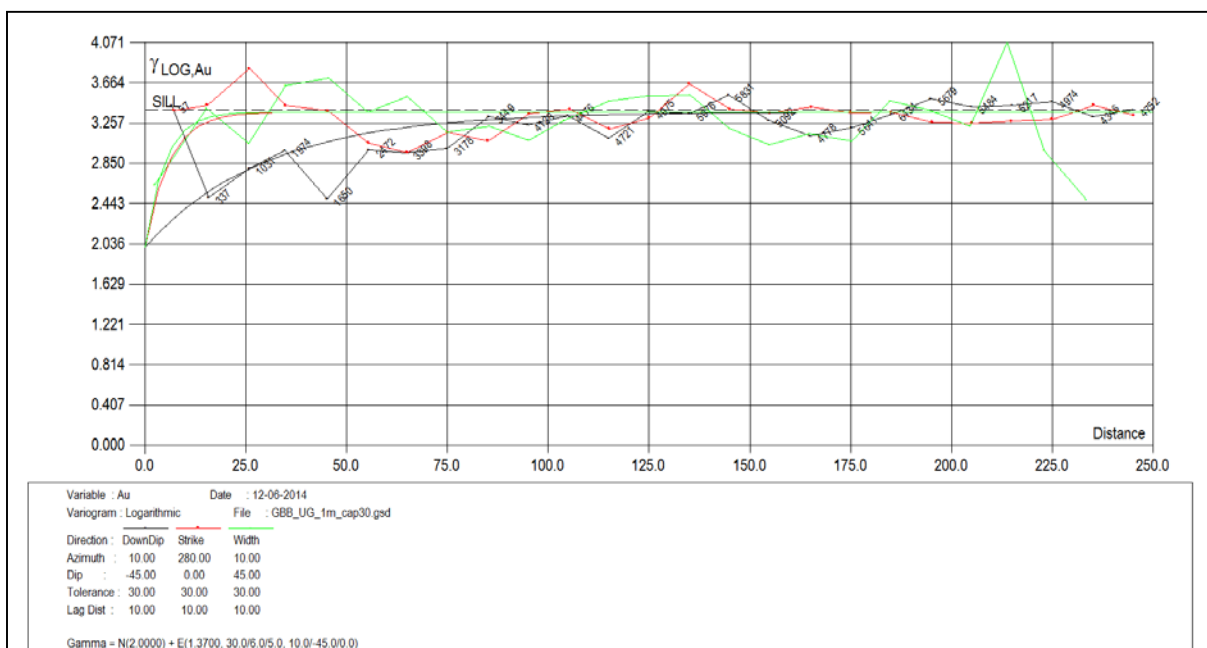

Figure 14-24: Variogram of 1 m Au composites Log capped at 30 g/t

14.2.4.2 Estimation parameters

The 1 m composites were restricted to the limits of the Boolean solid and a block model of 2.5 x 1.25 x 1.25 m was generated. The resource estimate was calculated using the inverse distance squared method and two passes of disc ellipses, oriented down-dip as supported by the variographic analysis. Figure 14-25 displays the block model generated. Table 14-3 outlines the estimation parameters.

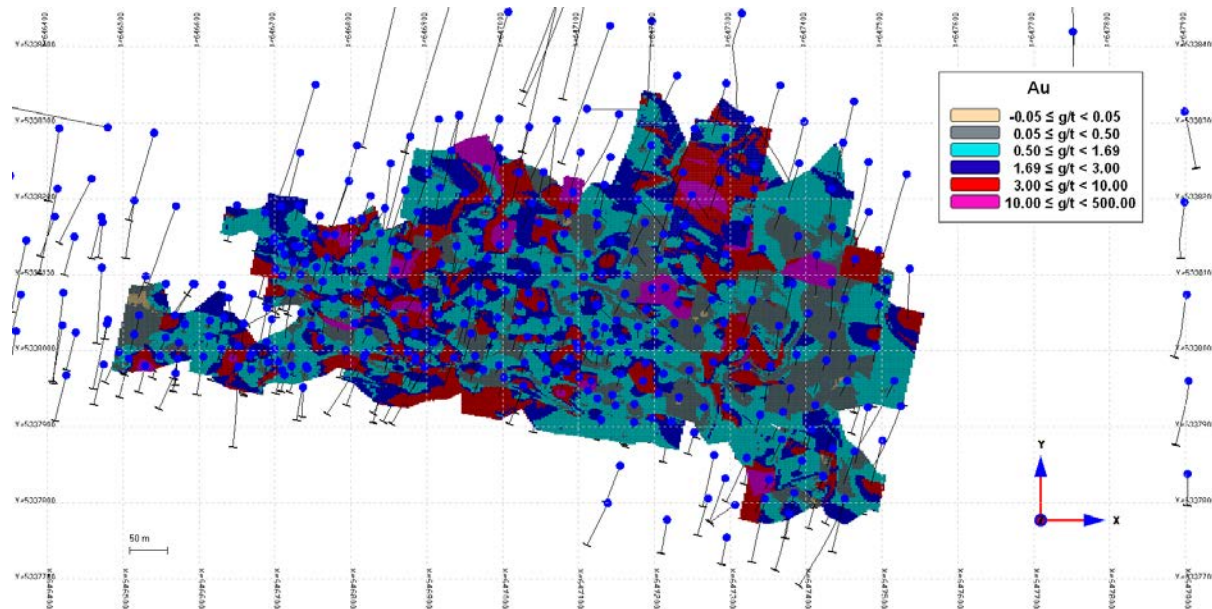

Figure 14-25: Plan view of the block model cut to overburden surface

Table 14-3: Block model parameters

Pass	Azimuth	Dip	Spin	X (m)	Y (m)	Z (m)	Minimum Samples per Block	Maximum Samples per Block	Minimum Drillholes
1	10	-45	5	100	75	20	3	8	2
2	10	-45	5	150	100	30	3	8	2

Figure 14-26 and Figure 14-27 display the ellipsoid used for pass 2 in the block model estimation. The primary ellipsoid axis was oriented down dip and an attempt was made to align the secondary axis (azimuth) along the strike of the mineralized solids to reduce the risk of populating blocks with composites of neighbouring mineralized solids.

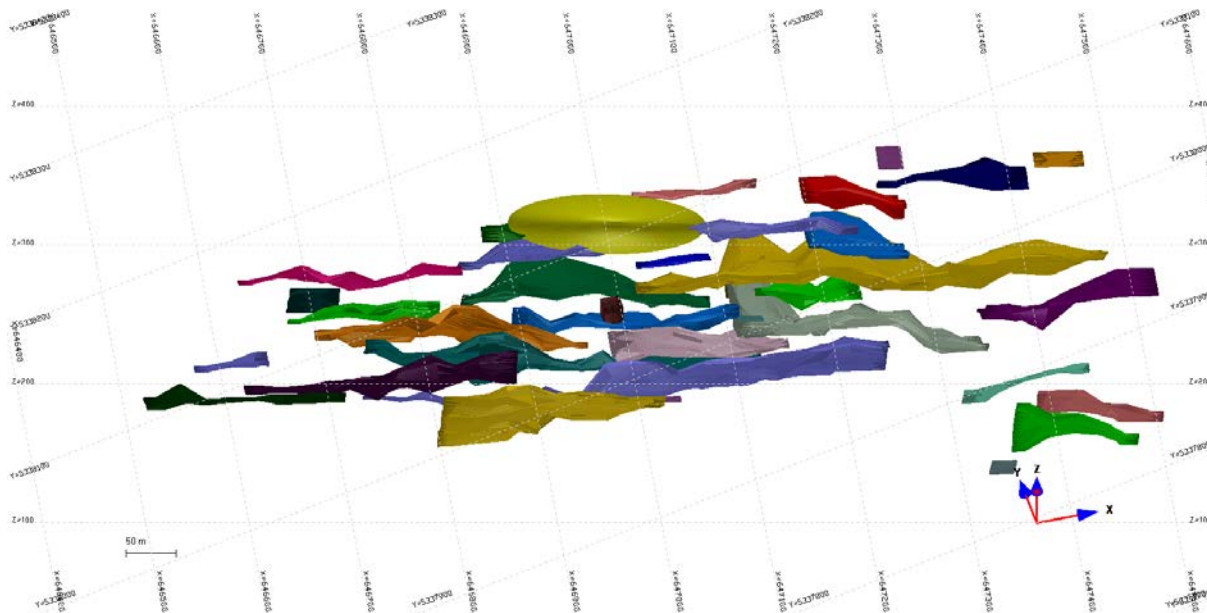

Figure 14-26: Ellipsoid for pass 2 of block model estimation. View looking down dip

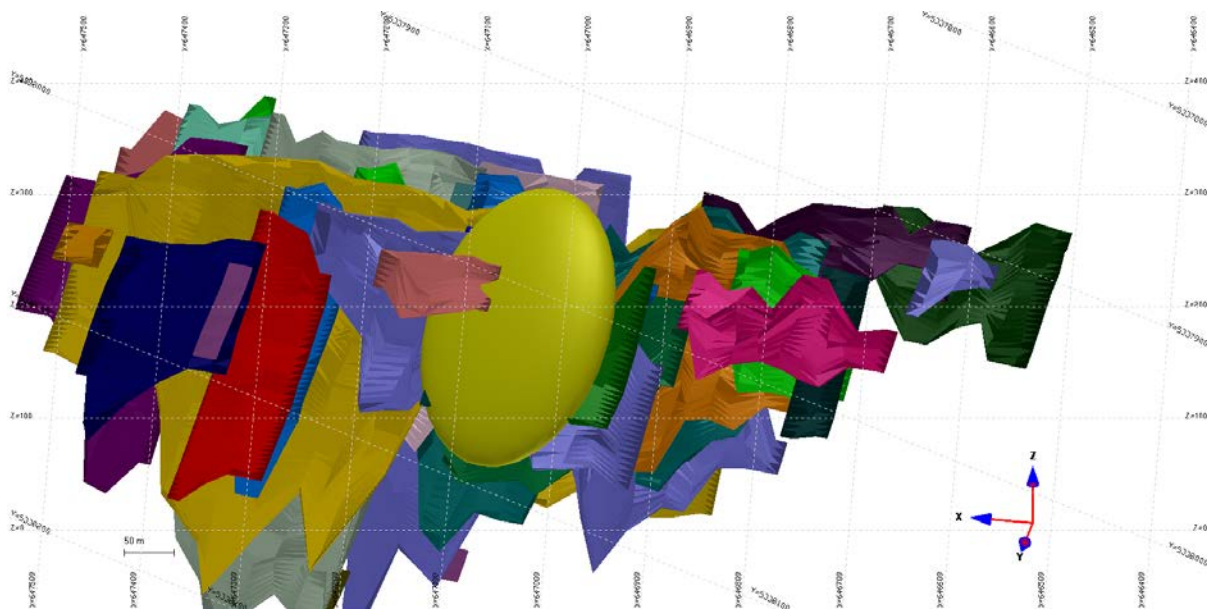

Figure 14-27: Ellipse for pass 2 of block model estimation. View perpendicular to dip

14.2.5 RESOURCE CLASSIFICATION

In this study the block resources in any given block are classified in an automatic manner and are not adjusted manually.

The Granada Gold deposit was classified using three passes of disc ellipsoids. The parameters are outlined in Table 14-4.

Table 14-4: Classification parameters

Category	Azimuth	Dip	Spin	X, Y (m)	Z (m)	Minimum Samples per Block	Maximum Samples per Block	Minimum Drillholes
Measured	10	-45	5	40	40	12	14	3
Indicated	10	-45	5	80	80	9	14	3
Inferred	10	-45	5	120	120	6	14	3

As usual, the automatic classification has its drawbacks but in general reflects the level of confidence even if we observe “Swiss cheese” or “spotted dog” patterns with patches of measured alternating with patches of indicated or inferred resource categories.

Figure 14-28 to Figure 14-35 display the mineralized intervals and respective solids. The block model displayed is extracted using an optimized pit designed with Whittle software.

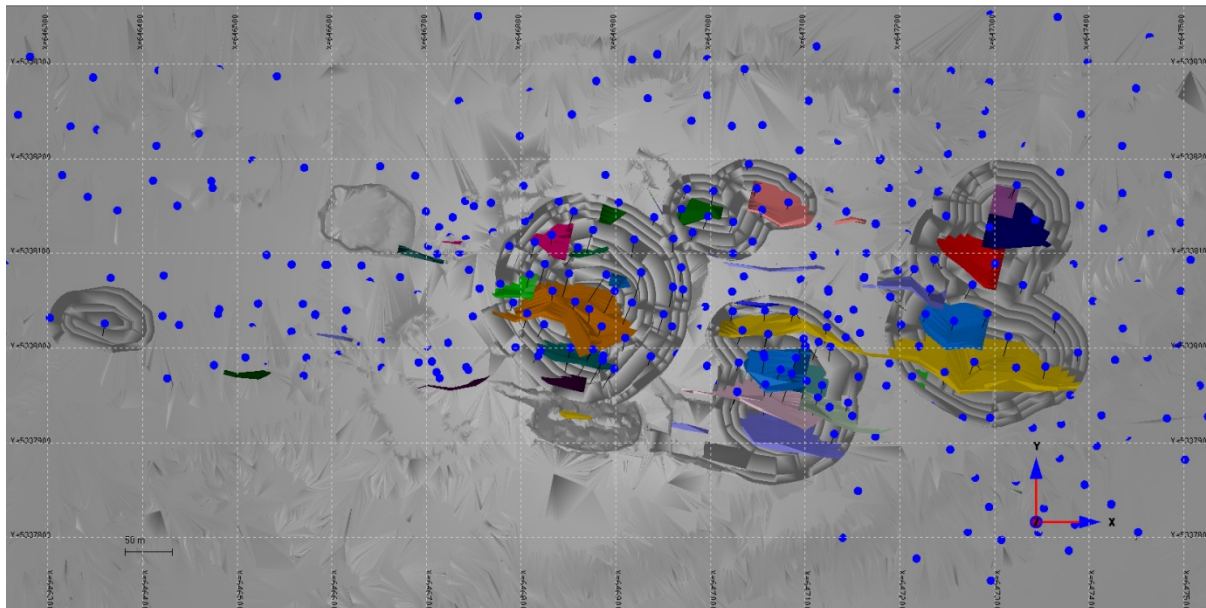

Figure 14-28: Plan view of the mineralized solids extracted above the optimized pit shell

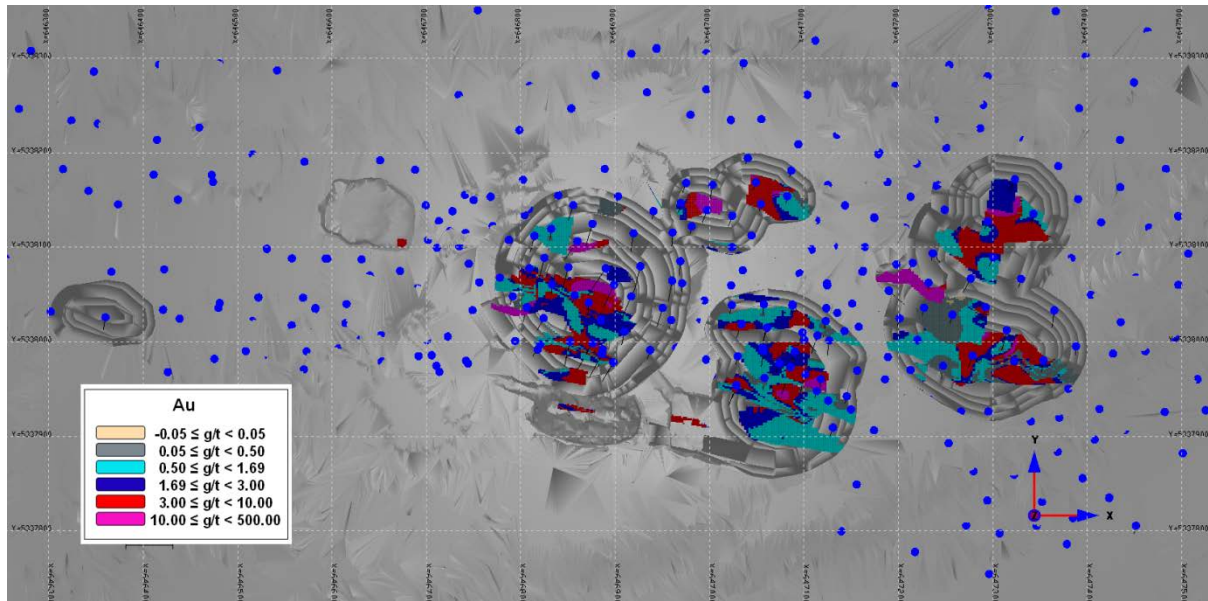

Figure 14-29: Plan view of the block model extracted above the optimized pit shell

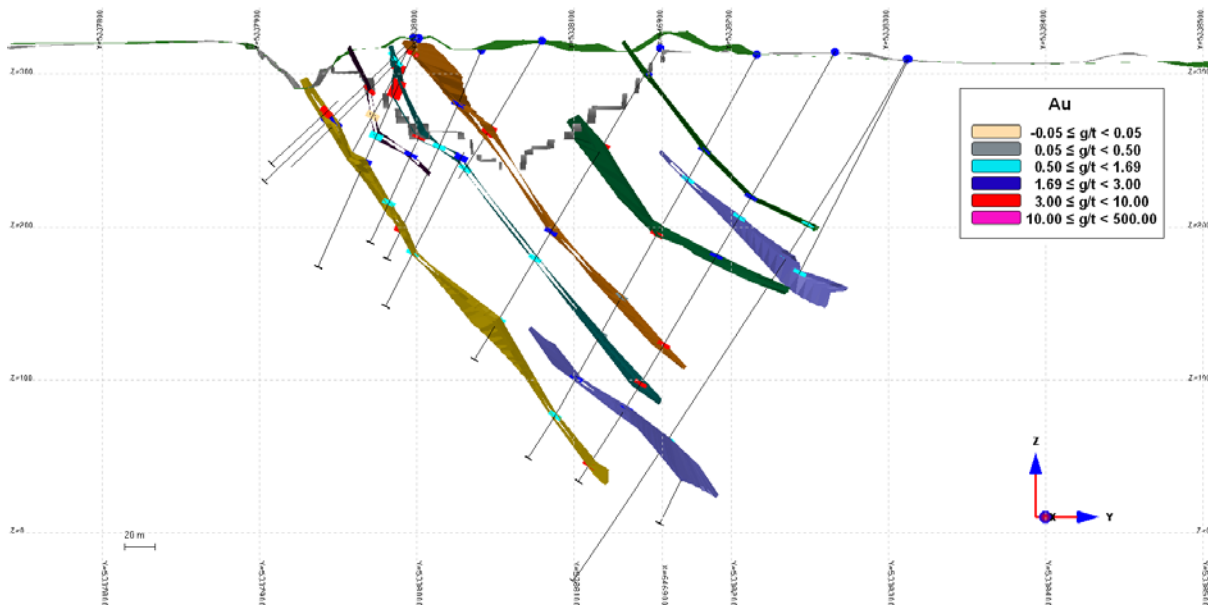

Figure 14-30: Mineralized intervals within their respective solids. Section 11 with a 25m viewing corridor looking WNW, azimuth of 283°

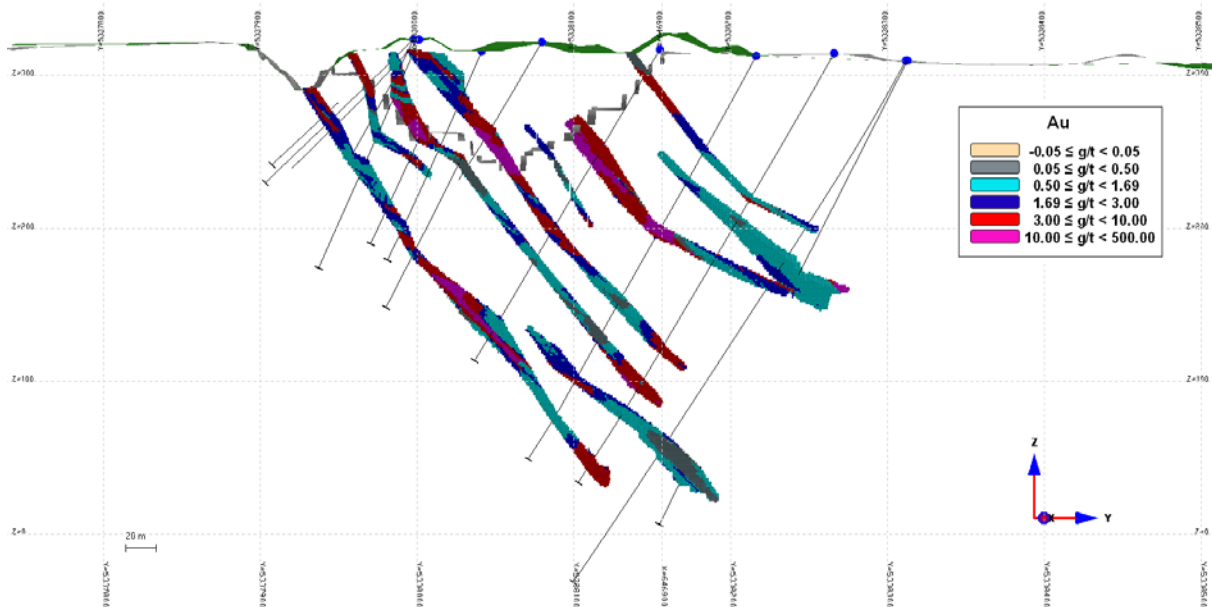

Figure 14-31: Au estimation of block model. Section 11 with a 25m viewing corridor looking WNW, azimuth of 283°

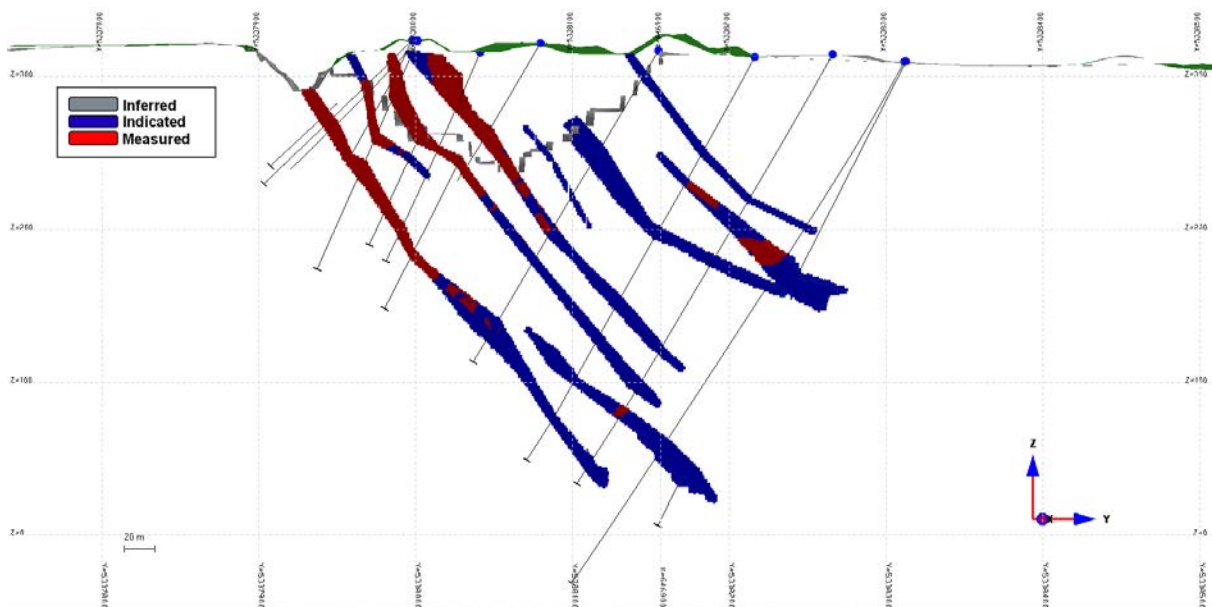

Figure 14-32: Classification of block model. Section 11 with a 25m viewing corridor looking WNW, azimuth of 283°

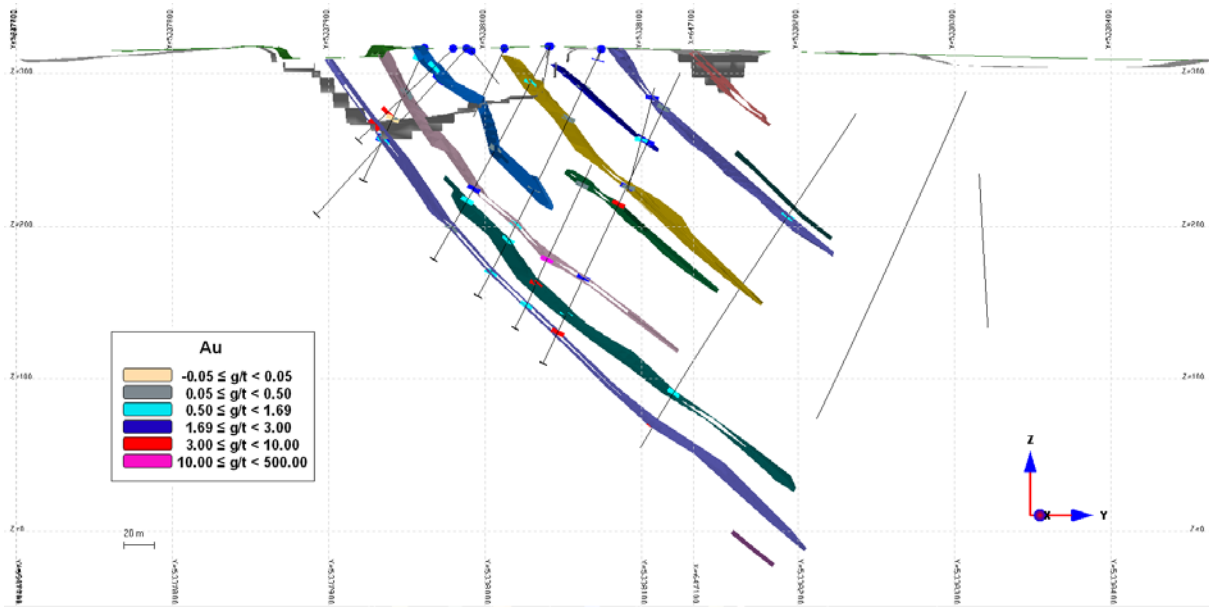

Figure 14-33: Mineralized intervals within their respective solids. Section 19 with a 25m viewing corridor looking WNW, azimuth of 283°

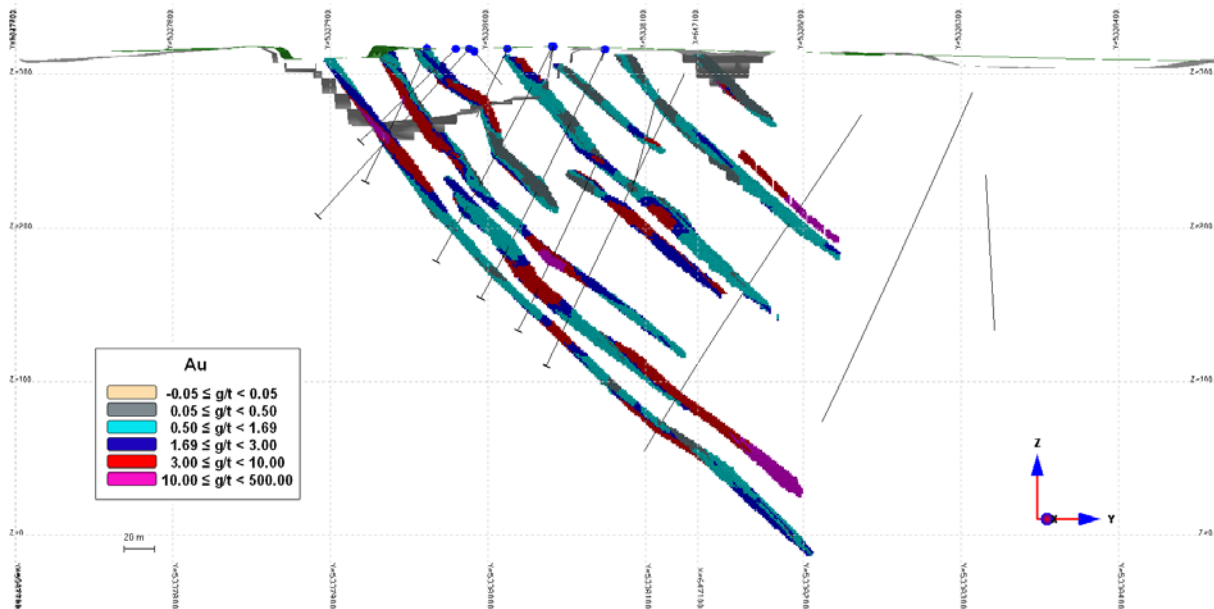

Figure 14-34: Au estimation of block model. Section 19 with a 25m viewing corridor looking WNW, azimuth of 283°

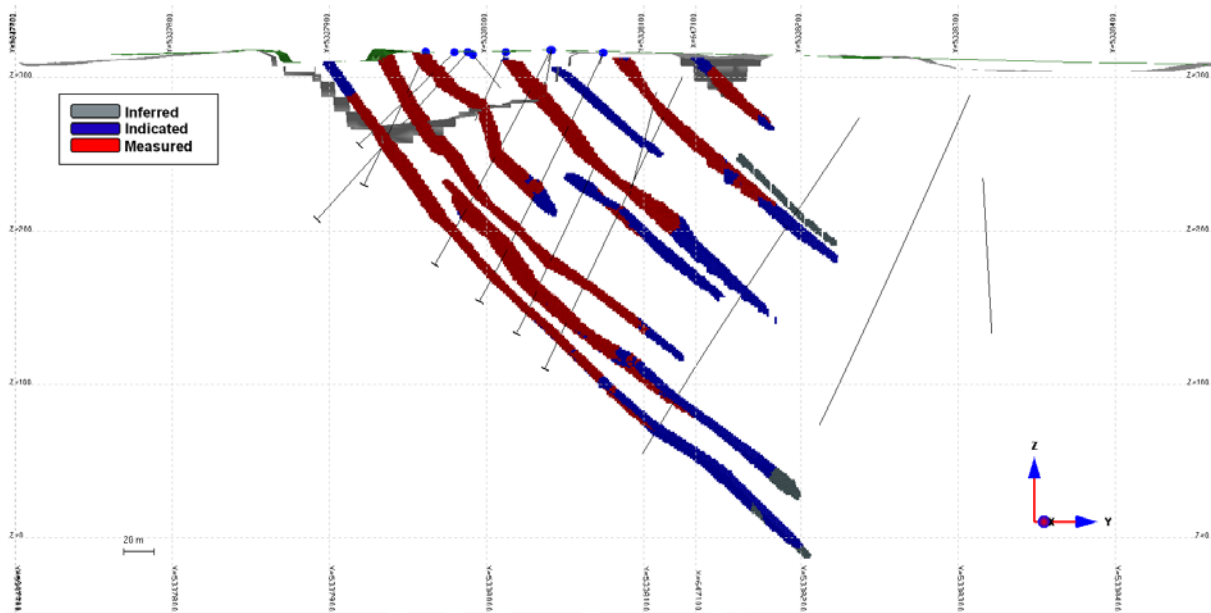

Figure 14-35: Classification of block model. Section 19 with a 25m viewing corridor looking WNW, azimuth of 283°

Figure 14-36 to Figure 14-39 display the resource estimation and classification for tonnage beneath the depth of the pit, 237.5 m. This material cannot presently be considered when calculating the reserves however, should the price of gold increase, it has good potential if the pit were to expand.

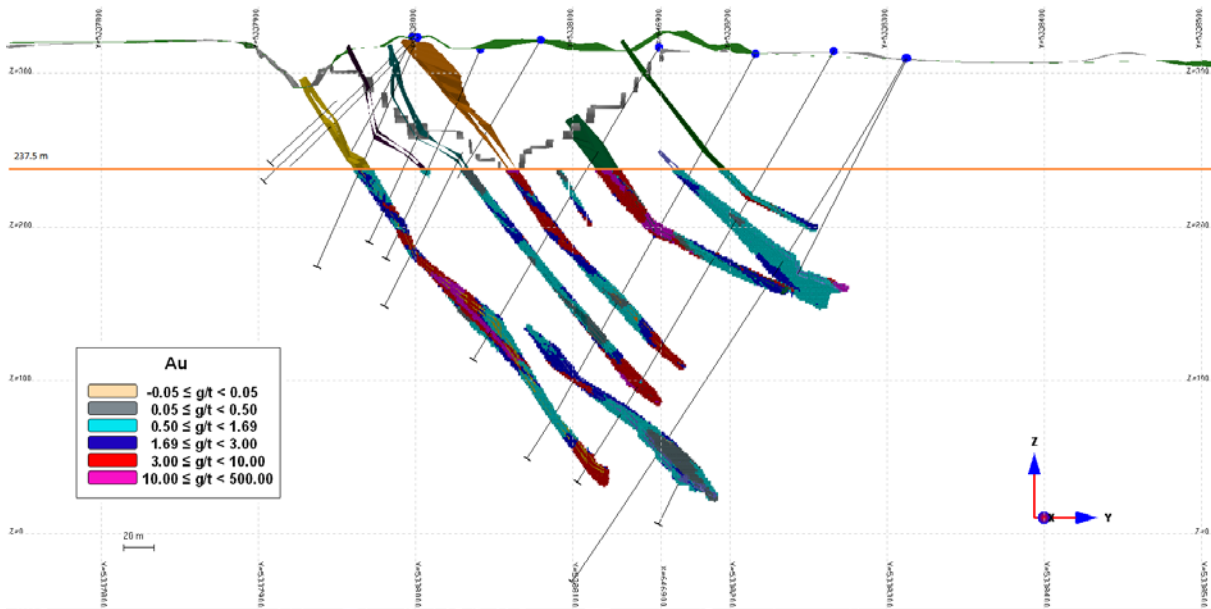

Figure 14-36: Estimation beneath the depth of 237.5m. Section 11 with a 25m viewing corridor looking WNW, azimuth of 283°

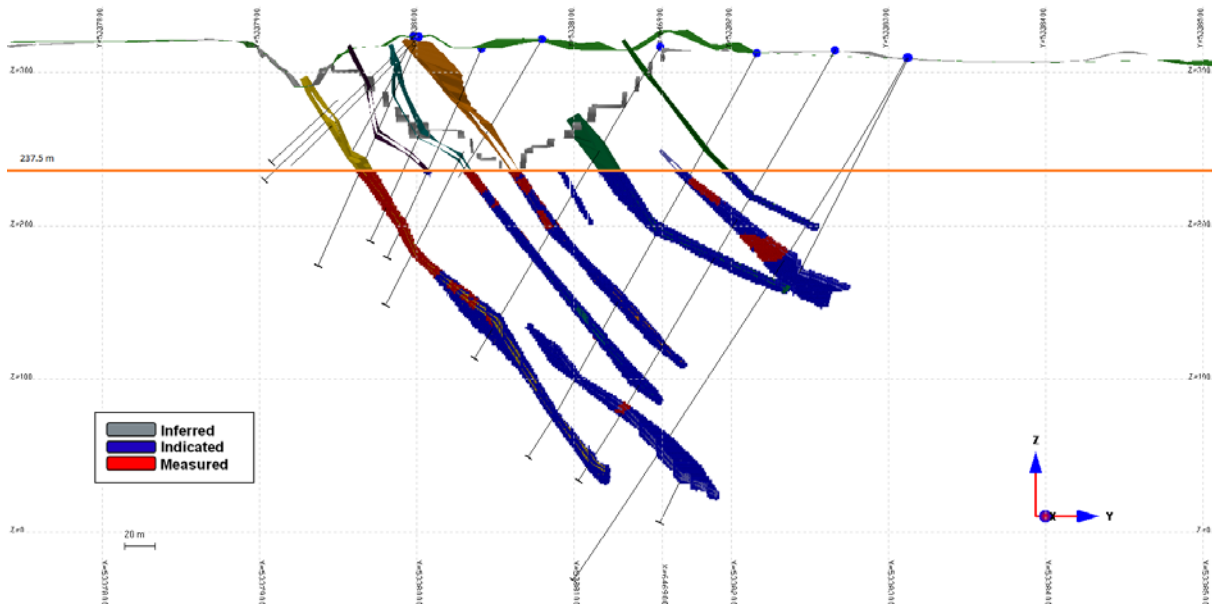

Figure 14-37: Classification beneath the depth of 237.5m. Section 11 with a 25m viewing corridor looking WNW, azimuth of 283°

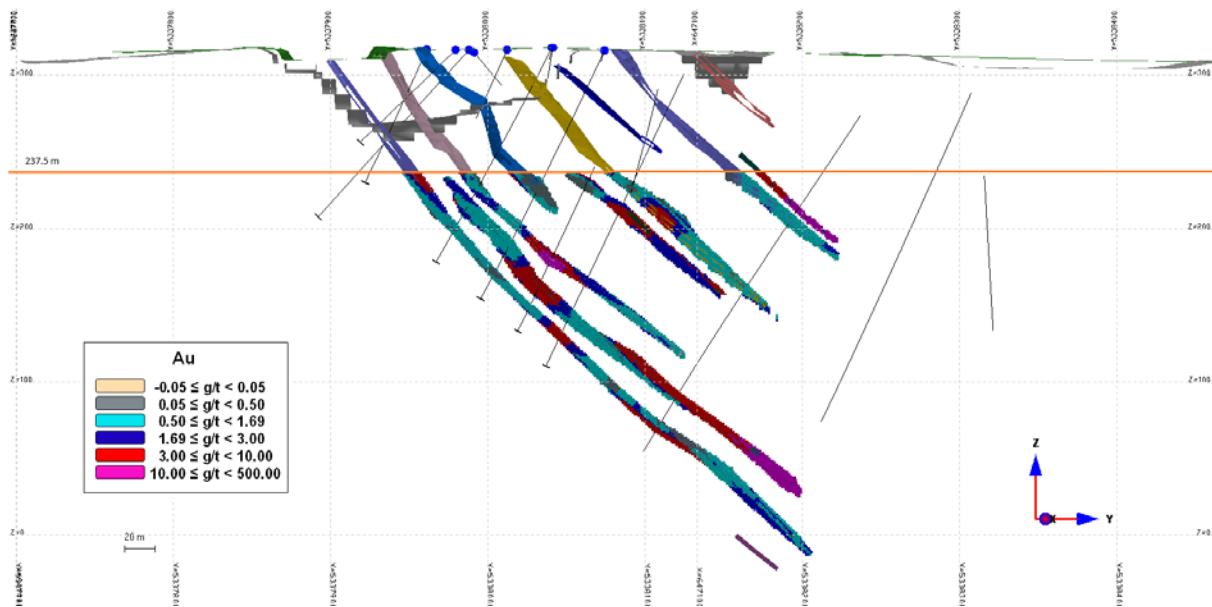

Figure 14-38: Estimation beneath the depth of 237.5m. Section 19 with a 25m viewing corridor looking WNW, azimuth of 283°

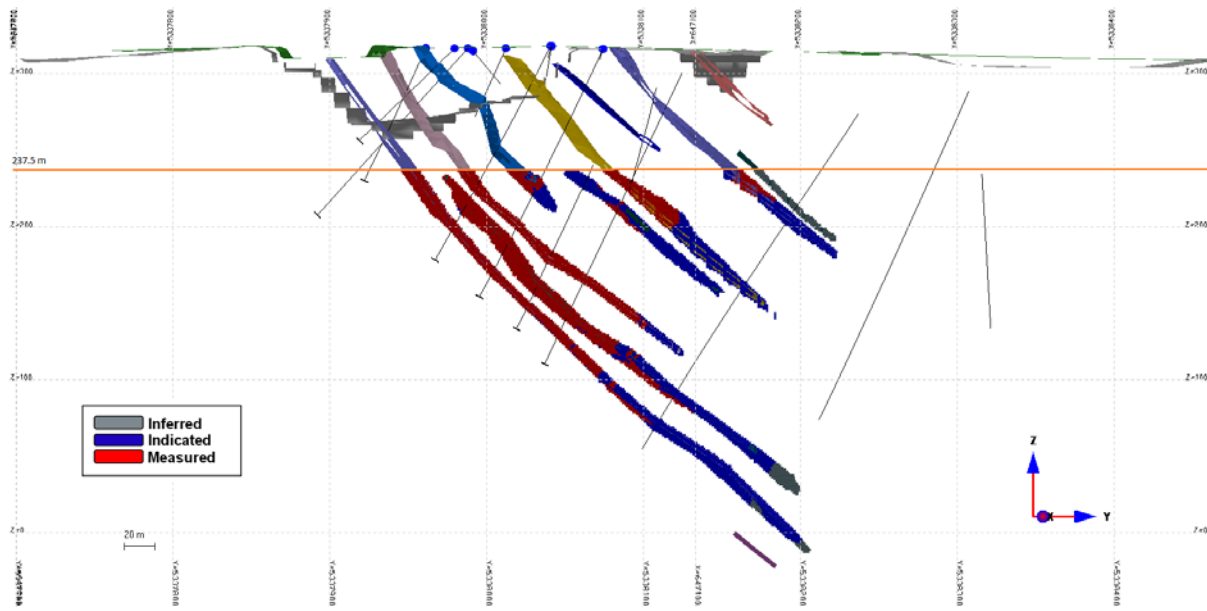

Figure 14-39: Classification beneath the depth of 237.5m. Section 19 with a 25m viewing corridor looking WNW, azimuth of 283°

14.3 GLOBAL RESOURCES

Estimated mineral resources of the Granada gold project are simply obtained by adding resources in blocks with an estimated grade above any given cut-off. Resource tonnage of a block is: $5m \times 2.5m \times 5m \times 2.7t/m^3 = 168.75t$ for a full block (100% below overburden/topo surface).

In the context of re-engineering to increase robustness of the Granada project, Mineral resources have been remodeled with mineral zones having a minimum horizontal width of 7m down to elevation 237.5m. This resource model has been used for pit optimization and design for the “Rolling Start” project. This model starts from the surface and pit bottom to elevation 237.5 metres.

A cut-off grade of 1.69 g/t was used in the resource estimation and composites were capped at 30 g/t. A density of 2.7 t/m³ was used in the calculation of tonnage. The outcome is displayed in Table 14-5.

Table 14-5: In-Pit Resource using an optimal Whittle pit and a cut-off grade of 1.69 g/t*

Resource Class	Tonnes (t)	As	Au	Au
		ppm	g/t	oz
Inferred	21,000	131	5.57	3,800
Indicated	369,700	576	5.52	65,600
Measured	152,500	850	4.64	22,700
Indicated+Measured	522,200	656	5.26	88,300

*Mineral resources that are not Mineral Reserves do not have demonstrated economic viability. CM definitions were respected for mineral resources. See Reserves section (no dilution or mining loss shown here).

Tonnage beneath the Whittle surface pit to a maximum depth of 237.5 m was estimated in the same manner. The outcome is displayed in Table 14-6.

Table 14-6: Resources beneath the Whittle pit to a depth of 237.5m, also applying a cut-off grade of 1.69 g/t*

Resource Class	Tonnes (t)	As	Au	Au
		ppm	g/t	oz
Inferred	33,500	1,071	6.85	7,400
Indicated	462,000	840	3.72	55,000
Measured	371,500	1,035	3.10	37,000
Indicated+Measured	833,500	927	3.44	92,250

*Mineral resources that are not Mineral Reserves do not have demonstrated economic viability. CM definitions were respected for mineral resources.

In order to address mining underground, mineralized zones have been remodeled with 3 to 4 meters horizontal width below elevation 237.5 metres. Estimated underground mineral resources of the Granada gold project are simply obtained by adding resources in blocks with an estimated grade above any given cut-off. Resource tonnage of a block is: $2.5m \times 1.25m \times 1.25m \times 2.7t/m^3 = 10.55t$ for a full block (100% below overburden/topo surface).

A cut-off grade of 3 g/t was used in the resource estimation and composites were capped at 30 g/t. A density of 2.7 t/m³ was used in the calculation of tonnage. The outcome is displayed in Table 14-7. The outcome of the combined underground (resource beneath the pit to a maximum depth of 237.5 m, CoG of 1.69 g/t, and resource beneath the depth of 237.5, CoG of 3 g/t) is displayed in Table 14-8.

Highlights include a Measured and Indicated combined underground gold resource of 325,450 ounces of gold at an average grade of 5.10 g/t gold plus 25,700 ounces Inferred at a grade of 7.14 g/t gold. The combined underground measured resource is 107,600 ounces (763,500 tonnes grading 4.38 g/t), indicated resource is 217,600 ounces (1,221,000 tonnes grading 5.54 g/t), inferred resource is 25,700 ounces gold (112,000 tonnes grading 7.14 g/t Au) using a cut-off grade of 0.40 g/t.

Table 14-7: Underground Resources beneath the depth of 237.5m, applying a cut-off grade of 3 g/t*

Resource Class	Tonnes (t)	As	Au	Au
		ppm	g/t	oz
Inferred	78,500	569	7.25	18,300
Indicated	759,000	1,306	6.66	162,600
Measured	392,000	1,024	5.60	70,600
Indicated+Measured	1,151,000	1,210	6.30	233,200

*Mineral resources that are not Mineral Reserves do not have demonstrated economic viability. CM definitions were respected for mineral resources.

Table 14-8: Combined Underground Resources, beneath the Whittle pit to a depth of 237.5m, cut-off grade of 1.69 g/t* and beneath the depth of 237.5m, cut-off grade of 3 g/t*

Resource Class	Tonnes (t)	As	Au	Au
		ppm	g/t	oz
Inferred	112,000	776	7.14	25,700
Indicated	1,221,000	1,127	5.54	217,600
Measured	763,500	1,028	4.38	107,600
Indicated+Measured	1,984,500	1,106	5.10	325,450

*Mineral resources that are not Mineral Reserves do not have demonstrated economic viability. CM definitions were respected for mineral resources.

Note and considerations: rounded numbers. The historical production of 51,476 ounces (181,744 sT @ 0.28 oz/sT) from 1930 to 1935 is included in the resource statement (cannot physically remove from measured, indicated or inferred) as the historical opening cannot be placed in 3D. Moreover, the historical mining apparently extends to the west where no mineral resources have been estimated due to impossibility to drill from old tailing surface. The author also wants to remind that grade estimations comes from Gold Bullion recent drilling, hence gold grades do not comes from historical data in the mined out sector.

14.4 CONCLUSIONS REGARDING THE ESTIMATION OF MINERAL RESOURCES

In the context of re-engineering to increase robustness of the Granada project, Mineral resources have been remodeled with mineral zones having a minimum horizontal width of 7m down to elevation 237.5m. This resource model has been used for pit optimization and design for the “Rolling Start” project. This model starts from the surface and pit bottom to elevation 237.5 metres. Lower grade is now excluded from the mineral resource statement. No gold loss has occurred from the PEA resource model to the actual presentation. It is all a matter of the mineral cut-off grade used with the associated economic scenario.

In order to address mining underground, mineralized zones have been remodeled with 3 to 4 meters horizontal width below elevation 237.5 metres. Highlights include a Measured and Indicated combined underground gold resource of 325,450 ounces of gold at an average grade of 5.10 g/t gold plus 25,700 ounces Inferred at a grade of 7.14 g/t gold. The combined underground measured resource is 107,600 ounces (763,500 tonnes grading 4.38 g/t), indicated resource is 217,600 ounces (1,221,000 tonnes grading 5.54 g/t), inferred resource is 25,700 ounces gold (112,000 tonnes grading 7.14 g/t Au) using a cut-off grade of 0.40 g/t.

Previous small open pits have been taken into account and are starting surfaces of optimization. The historical production of 51,476 ounces (181,744 sT @ 0.28 oz/sT) from 1930 to 1935 is included in the resource statement and the author cannot physically remove it from the measured, indicated or inferred categories. As the historical opening cannot be placed in 3D. Moreover the historical mining apparently extent to the west where no mineral resources have been estimated due to impossibility to drill from old tailing surface. The author also wants to remind that grade estimations comes from Gold Bullion recent drilling, hence gold grades do not comes from historical data in the mined out sector.

- Accuracy of the disclosure on what has been mined out underground. The amount of material mined out is limited, however it could be a bit more than disclosed but not to a huge extent since it would be reflected with a much larger tailing footprint.
- Combination of additional factors which could materially affect the resources are:

- The presence of old orphan tailings
- The presence of arsenic in the rock at Granada

14.5 RECOMMENDATIONS REGARDING THE ESTIMATION OF MINERAL RESOURCES

It is recommended to undertake negotiation and clean-up of the orphan tailings (dating from 1935) with the Ministry of Natural Resources Quebec in order to enable exploration drilling to the northwest of existing drilling to validate extension of the mineralized package at depth (old tailings location). It is also recommended to do additional drilling to improve resource estimates in the open pit area lateral extension. It is also recommended to complete the drilling to the west, to the north and to the east on a 40 to 50 m grid of surface holes drilling southward at 55 degrees dip. A few infill holes where gap exists and 3 cross-sections of 3 holes on 100 m line to tests mineralization on the claims to the west. There are 3 target depths which merit additional drilling. One is near surface which we can define as 0-100, from 100 to 400 meters and deeper which is 400 to 1000 meters vertical depth, The deep drilling of 2012, the DUP holes have confirmed extension of gold mineralisation at 1Km vertical depth showing the system is still open. The author also wants to mention that the property has not been explored extensively by diamond drilling and some budget should be put on testing extensions when the economic conditions allows for that type of work.

The exploration work program & others – Step 1 – 2014/2015 is estimated as follow:

Exploration Budget on the Granada Project (CAN\$)

Trenching (exploration)	\$75,000
Drilling (definition, exploration (0-400m))	\$2,500,000
Geotech Drilling (try to increase pit slope)	\$75,000
Laboratory met testings	\$50,000
Supervision and Technical reports	\$150,000
Deep drilling program Phase 2 targeting mineralization depth (400-1000m)	\$5,000,000
<u>Estimated total cost</u>	<u>\$7,850,000</u>

15 Mineral Reserve Estimates

The reserves derived from the detailed pit design have been estimated in accordance with the definitions and guidelines adopted by the Canadian Institute of Mining, Metallurgy, and Petroleum (CIM Standards on Mineral Resources and Reserves). The reserves are based entirely on measured and indicated resources and were converted as probable and proven reserves respectively.

The mineral reserves (with dilution and ore loss) is therefore equal to 569,000 tonnes of ore at an average grade of 4.24 g/t Au using cut-off grades of 1.69 g/t and represents an operation of 3.0 years. The entire reserve comprises 77,500 ounces of gold (before processing recovery). Total waste, including rock, inferred resources and overburden, is 9.3 Mt; resulting in a waste to ore ratio of 16:3. The detailed mineral reserve estimate is shown in Table 15-1:

Table 15-1: Granada Project Reserves (presented as mill feed)

Material Type		Cut-off g/t Au	Material tonnes	Grade g/t Au	Au** ounces
Ore*	Proven Reserves	1.69	170,000	3.72	20,500
	Probable Reserves	1.69	399,000	4.46	57,000
	Total	1.69	569,000	4.24	77,500

* Presented as mill feed (with 25 % mining dilution and a 10% ore loss)

** Presented as mill feed (before processing recovery)

16 Mining Methods

The mining of Granada deposit will follow the standard practice of an open-pit operation with the conventional drill and blast, load and haul cycle, using a drill / truck / excavator mining fleet, and supported by a fleet of auxiliary equipment. The run-of-mine (RoM) will be drilled, blasted and loaded by hydraulic excavators and delivered by trucks to an ore stockpiling area. The ore will then be loaded onto transport trucks and delivered to the lamgold processing plant, approximately 43 km from the mine site. Waste rock material will be hauled to the waste disposal areas near the pits or backfilled into the mined pits.

It has been assumed that the mining of the Granada deposit will be carried out by a mining fleet that will be leased and maintained by the Owner. An alternative option would be to contract out all activities related to mining, but this was not incorporated into the PFS.

16.1 OVERALL PIT SLOPE ANGLE

SGS mandated GoldMinds to assist with the pit and waste dump slope design component of the Pre-Feasibility Study. The objectives of the study were to model and provide parameters for designs.

- Soil and rock characterization;
- Overburden slope configurations;
- Rock slope configurations;
- Recommendations concerning slope stability.

SGS/GoldMinds carried out preliminary site investigation field visits in 2013 especially for site location for an onsite mill scenario and a tailing ponds possible location. A geotechnical drilling program was prepared. As scenario was about to change to custom milling, the extensive geotechnical program was postponed. As the scenario has changed not as much room was required. Information gathered in the field has allowed selection of the sites with the most favourable parameters in terms of stability and the lowest impact on the environment and the community.

A short geotechnical drilling program will be required in order to increase the pit slope if client wishes to have steeper walls. This is in addition to complementary geotechnical drilling for the north end of the North dump to verify if installation of a geotechnical key will be required. Some portions have soil between outcrops and may require local fine tuning.

16.1.1 OVERBURDEN

Overburden in the pit area is mainly made of glacial till with sand and gravels. Of course a portion of the overburden in the sector of the study is made of older waste rock making a patio.

Overburden is relatively shallow compared to other projects in the Abitibi region.

In the waste dump sectors significant amount of outcrops are present. The first dump to be used is the most eastward and overburden thickness is less than a 1 meter. The top soil and base till with clayish content should be bulldozed and preserve for reclamation. As well as the first dump, the covers should be stripped for further use. This should basically bring most of the waste dump to sit directly on the bedrock or overburden less than 2 meters. As previously mentioned should a sector with greater overburden be encountered during site preparation, specific localised geotechnical drilling may be required to increase the stability by preparation of a Key at the bottom of the slope. For those not familiar with the geotechnical key in a waste dump; it is the extraction of the soil by trench and replacement by rock of coarse size to increase friction. The position of the Key is usually covered by a minimum of one bench of material to increase its shear resistance. The author has already used this technique to guarantee stability of dumps at Bedford and Marbleton Québec.

The observed overburden in the area of the project is not considered sensitive.

The contact between the bedrock and overburden is sharp, with the bedrock along the contact showing a slight weathering profile consistent with increased fracturing and slightly weaker material. The rock shows good rock mass quality. The main geological feature that will be seen along the pit walls at Granada is the bedding of the conglomerates which strikes east-west and dips northward (i.e., strike/dip = 260°/45°-65°) and is characterized by hydrothermal alteration around the quartz vein system. There are also some NNE-SSW faults and some minor faults. The Granada conglomeratic formation occurs south of the Cadillac Fault.

16.1.2 OVERBURDEN SLOPE CONFIGURATION

The pit slope recommendations for the overburden are:

- Maximum slope height of 10 m;
- Bench face (or batter) angles of 38°
- Bench heights of 5 with 2 meters berm with an overall slope of 31° should generally be suitable within the material observed at the areas of work.

The excavability, workability and trafficability of the overburden during the pit development and the stability of the overburden slopes are strongly dependent upon the location of the phreatic surface/groundwater level in each of the main soil units. Adequate drainage of overburden slopes, both during and after excavation, is necessary to minimize pore pressures in the slope face and maintain slope stability.

Recommendation concerning the overburden slope stability should be oriented at preparing drainage ditches which should be installed along the outside perimeter of the pit in order to collect and channel surface water away from the pit slopes;

16.1.3 ROCK SLOPE CONFIGURATION

The main consideration for the rock slope configurations within the planned Granada small pits within the fresh bedrock remain for rock slope failure mechanisms would be to structurally control mechanisms (kinematics), including planar, wedge and toppling. Review of similar conditions has been done in addition to validation of the existing slope that was achieved without failure in the old pit number one. The current configuration as shown in design sections in dry conditions brings the safety factor above 2 overall. This does not prevent local wedging events and the personal will have to monitor the pit slope for verification of the wall conditions.

16.1.4 PIT SLOPE PARAMETERS

The slope specifications and benching arrangements were provided by GoldMinds Geoservices Inc. Slope analysis by GoldMinds relies on RQD data analysis and mostly existing pit slope conditions which were proved stable at Granada. The slopes were provided as constant values for the entire pit (i.e. there were no sector divisions). The slopes and the definition of each technical term relating to benching configuration are shown in the Figure 16-1.

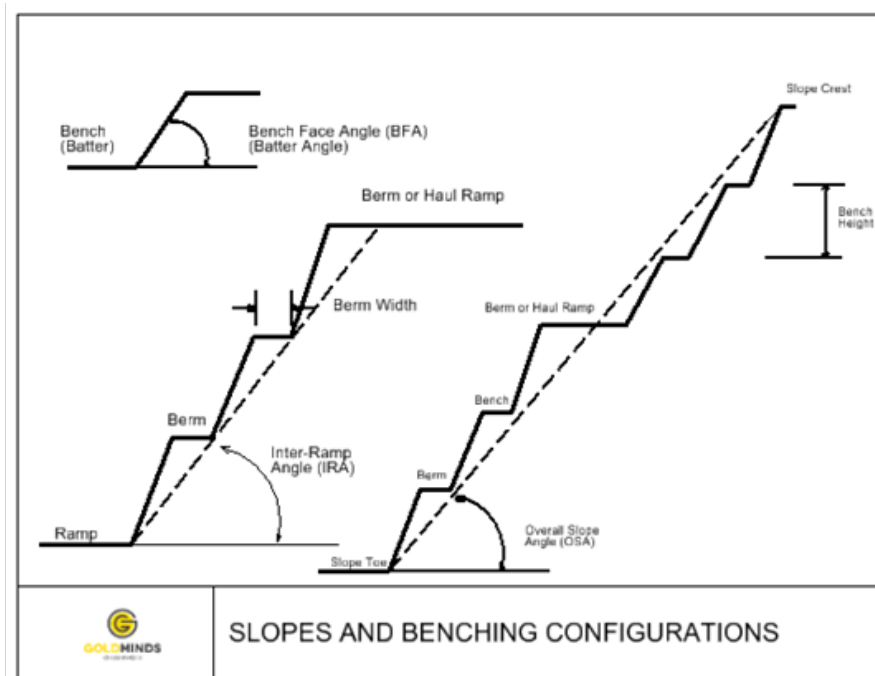

Figure 16-1: Definition of Slope and Benching Configuration

GoldMinds Geoservices provided recommendations for overburden slope of 30°, a bench face angle of 85°, inter-ramp angle of 55°, and a double-benching configuration (10m). The block height in the model is 5m; therefore the design assumption is that berms of 7.4m will appear at intervals of two block heights (10m bench height).

The recommended slopes are assuming dry conditions. Particular attention should be made to the dewatering of the pit, for each phase of excavation. In addition to follow-up on the behaviour of the NNE fault system which could generate wedges. Possibility to increase slope angle on the north wall, it will require additional drilling and oriented core at the scheduled face.

Regarding the pits which will mine over old workings of 1935, the detailed procedures will have to be put in place for the second year of operation since the first pit is into a never before mined sector. Basically once dewatering of the old pit (exception of old pit number one) investigation by CMS and laser scanning will be possible. The authors do not recommend the use of SONAR within drillhole for now as existing old workings could temporarily be accessed by Men in proper security conditions. Existing historical plans show that these openings should only be encountered at the bottom of the Western pit East of old pit number one. They should not affect significantly the mining operations as they are thin at 45 to 55 degrees but will require proper identification in 3D with procedures prior to operation in their vicinity.

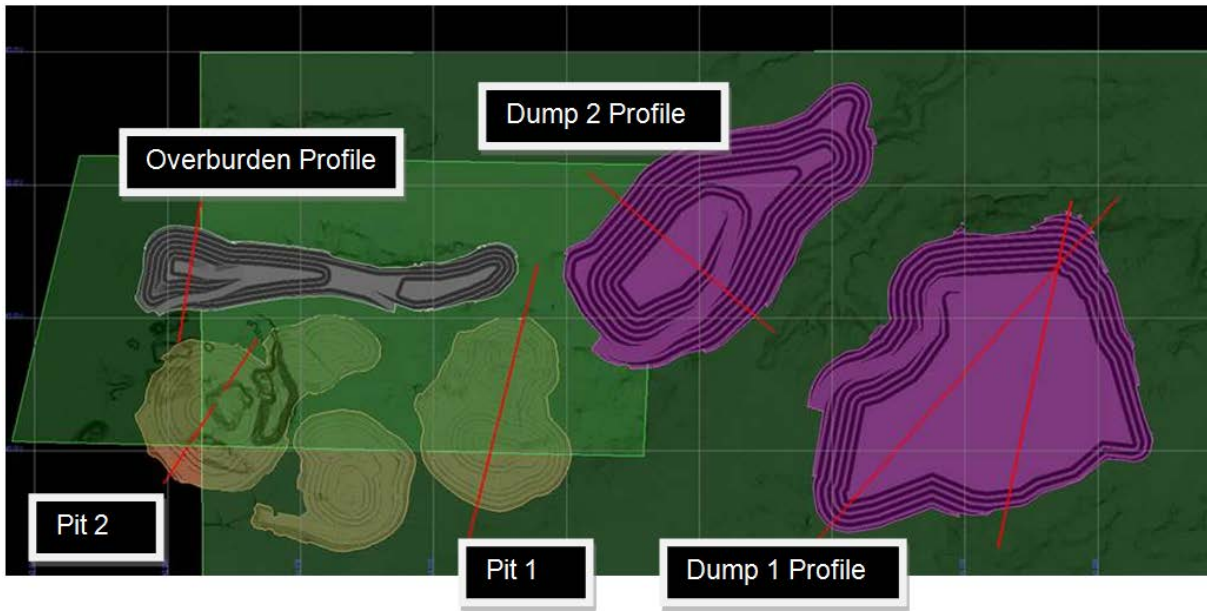

Figure 16-2: Plan view with position of Cross sections

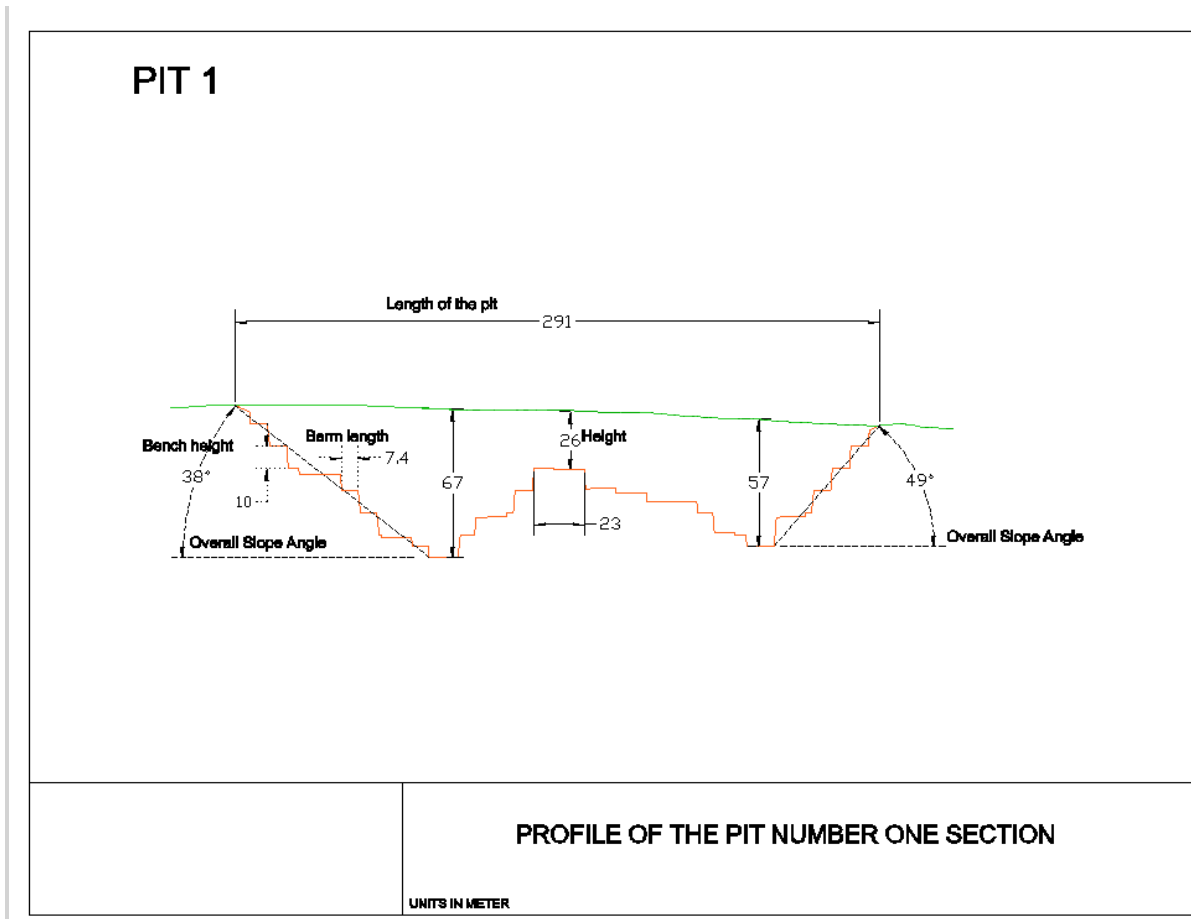

Figure 16-3: Typical profile of Pit number One

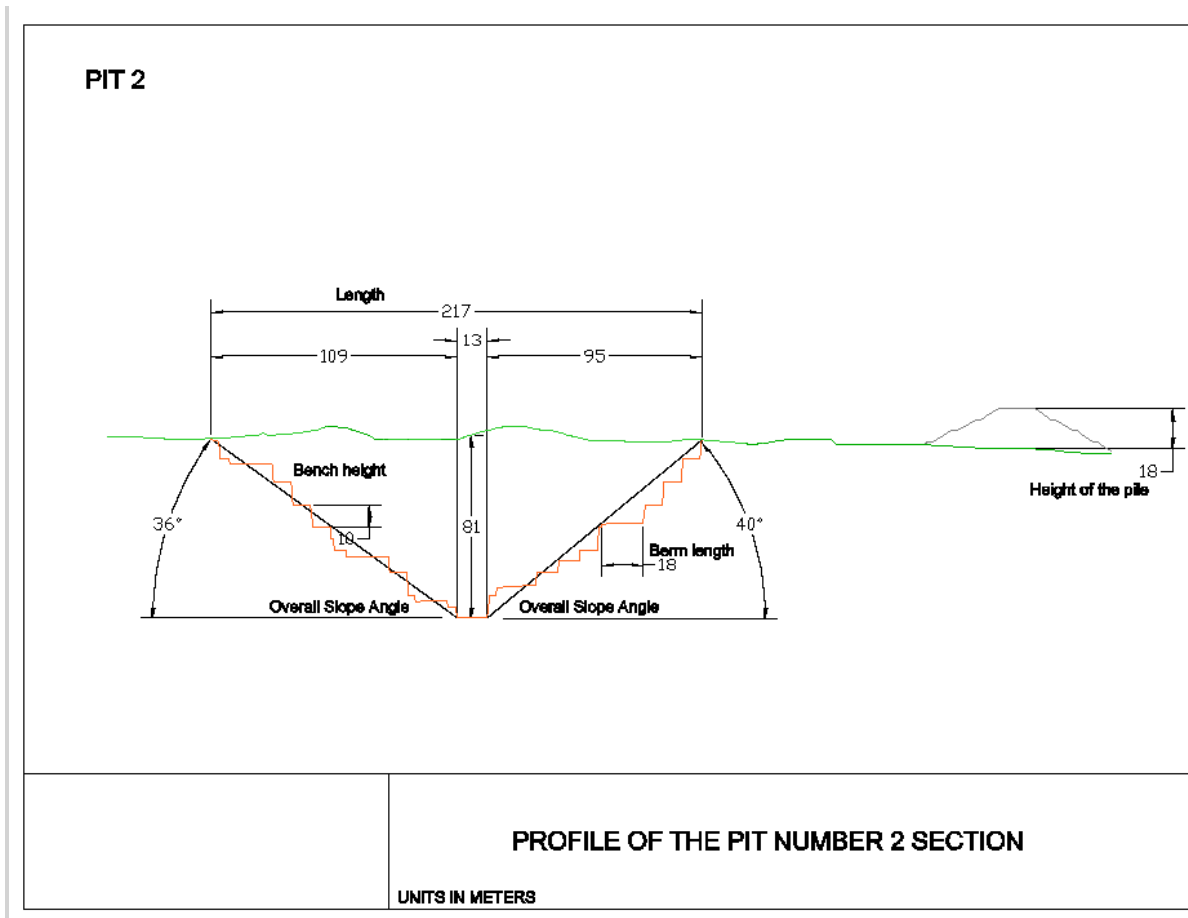

Figure 16-4: Typical profile of Pit number Two

16.2 PIT OPTIMIZATION PROCEDURE AND PARAMETERS

In order to develop an optimal engineered pit design for the Granada deposit, an optimized pit shell was first prepared using the Lerchs-Grossman 3D routine in Gems Whittle (“LG 3D”). The basic optimization principle of the algorithm operates on a net value calculation for each block in the model, in other words revenue from sales less total operating cost; mining, processing, and general and administration costs.

In accordance with the guidelines of the NI 43-101 and the Canadian Institute of Mine Metallurgy and Petroleum Definition Standards for Mineral Resources and Mineral Reserves, blocks classified in the Measured, Indicated and Inferred categories are allowed to drive the pit optimizer for a Preliminary Economic Assessment Study.

For the initial optimization, the required parameters were selected by SGS to evaluate the most economic open-pit profile. Although these parameters are not necessarily final, a reasonable degree of accuracy is required, since the analysis is an iterative process. The economic and operating parameters used in the initial optimization are given in the Table 16-1.

Table 16-1: Open pit Optimization Parameters

Items	Units	Value
Slope angle - Ovb	deg	30
Slope angle - Rock	deg	40
Mining cost - Ovb	Cdn\$/tonne	3.57
Mining cost - Waste	Cdn\$/tonne	5.01
Mining cost - Ore	Cdn\$/tonne	5.88
Mining recovery	%	90.00
Mining dilution	%	15.00
Processing cost + G&A	Cdn\$/t treated	51.00
Transport + Loading	Cdn\$/t treated	6.00
Ore mining increment	Cdn\$/t treated	0.87
Total Resource Based Cost	<i>Cdn\$/t treated</i>	57.87
Processing recovery	%	95.00
Gold price	US\$/oz troy	1,260
Exchange rate	Cdn\$/US\$	0.90
Gold price	Cdn\$/oz troy	1,400
Charges	Cdn\$/oz troy	3.00
Payable	%	99.935
Resulting gold price	Cdn\$/gram	44.89

Note: The economic and operational parameters used at the time of the pit optimization do not necessarily confirm those stated in the economic model

16.3 THEORETICAL PIT SHELL

Using the parameters presented above, the LG 3D pit optimizer was carried out to generate an optimum pit shell having the highest undiscounted cash flow. A three dimensional (3D) and plan view of the resulting LG 3D pit shells are shown in Figure 16-5. As can be seen in the Figure 16-5, the optimized pit shell of the Granada deposit is divided into few separated mining areas and is overlapping, in some locations, on the old open-pits.

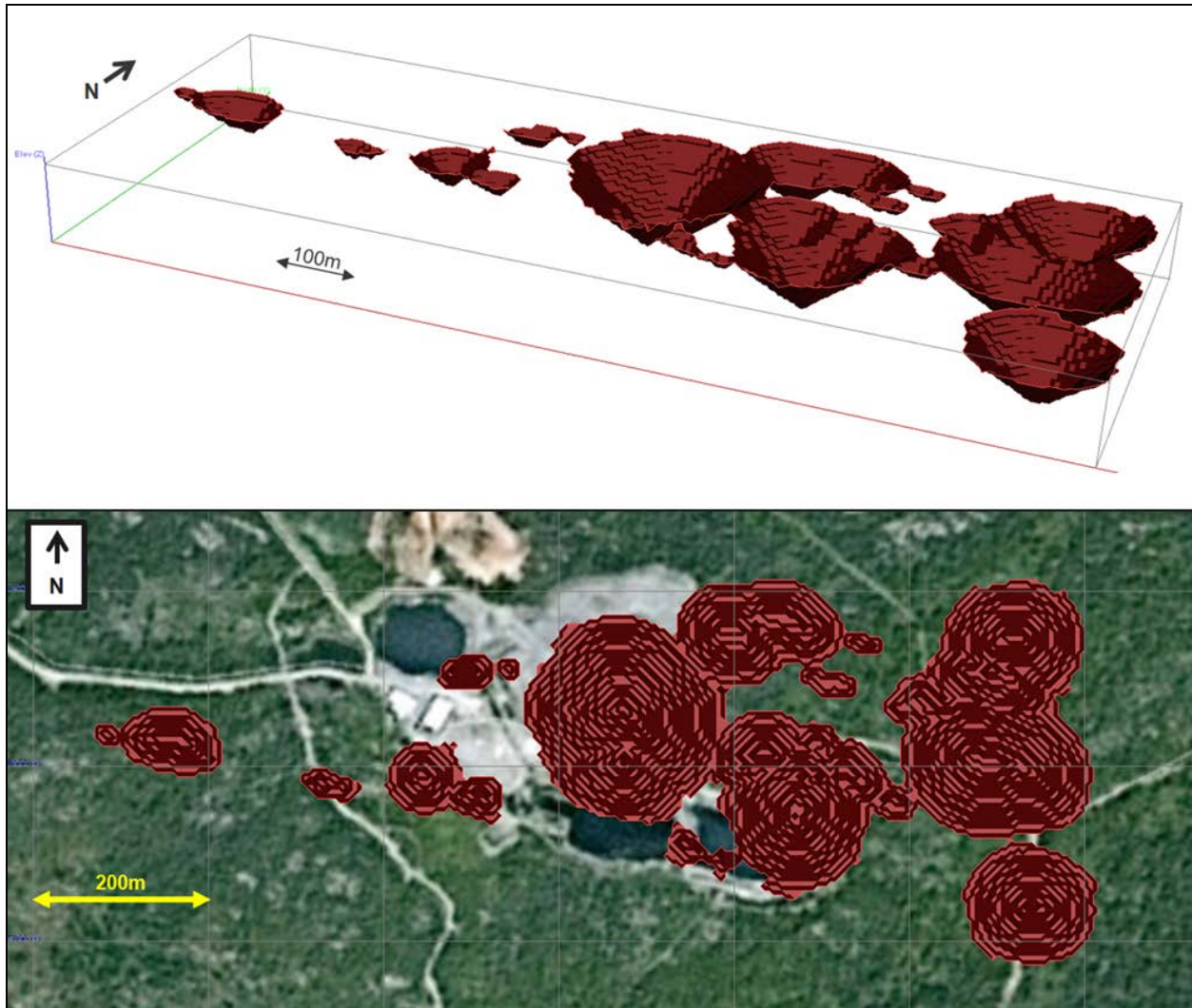

Figure 16-5: 3D and Plan view of the optimized shell

The theoretical pit shell resulting from the LG 3D optimization is only preliminary in nature and does not represent a practical design for mining, since it does not include an access ramp system or proper detailed pit slope and benching arrangement. The optimized pit shell will be used to serve as a guide for the engineered mine design, completed with the required operational haulage ramp, proper pit slope, and benching arrangement as presented in next section.

16.4 DETAILED MINE DESIGN

Using the base case shell as reference, an open-pit including a ramp and safety berms was designed to develop a more realistic mining scenario. The new designed pit will account for the additional waste material coming from the addition of a ramp to the base case shell. The design parameters used are defined as:

- Overall slope angle: 45°- 50° (depending of the ramps locations)
- Face angle: 85°
- Bench height: 10 m in waste and 5 m in ore
- Safety berm: 7.5 m width (1 safety berm at each 10 m vertically)

- Ramp grade: 12.0 % (single lane) and 10.0 % (two-lane)
- Ramp width: 13.5 m (single lane) and 18.3 m (two-lane)

The following figures (Figure 16-6 and Figure 16-7) showed a section view of the hauling ramp and the designed open-pit with his dimensions.

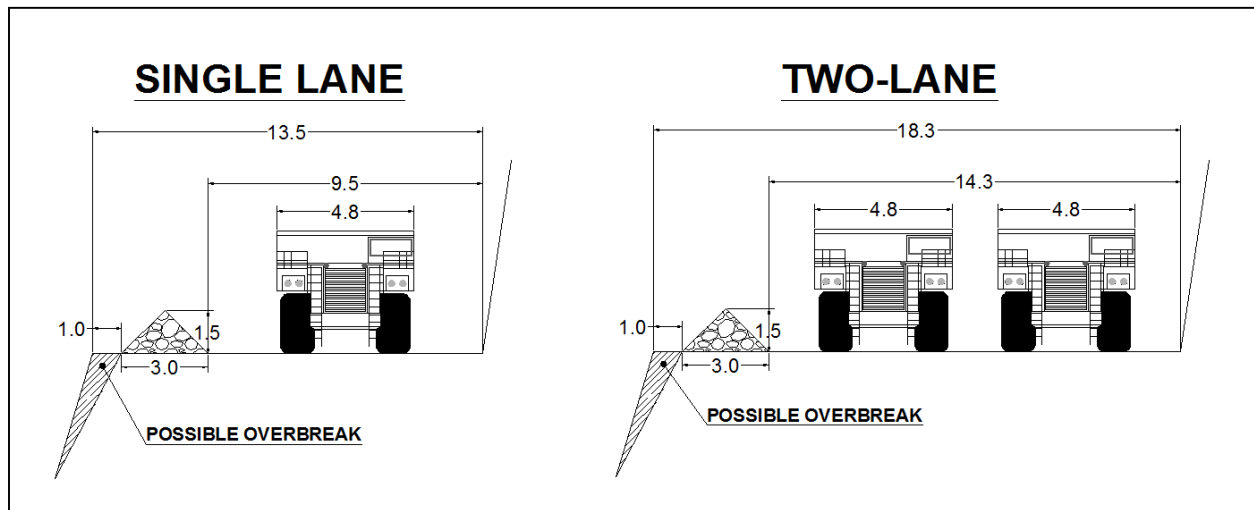

Figure 16-6: Section view of the in-pit ramp

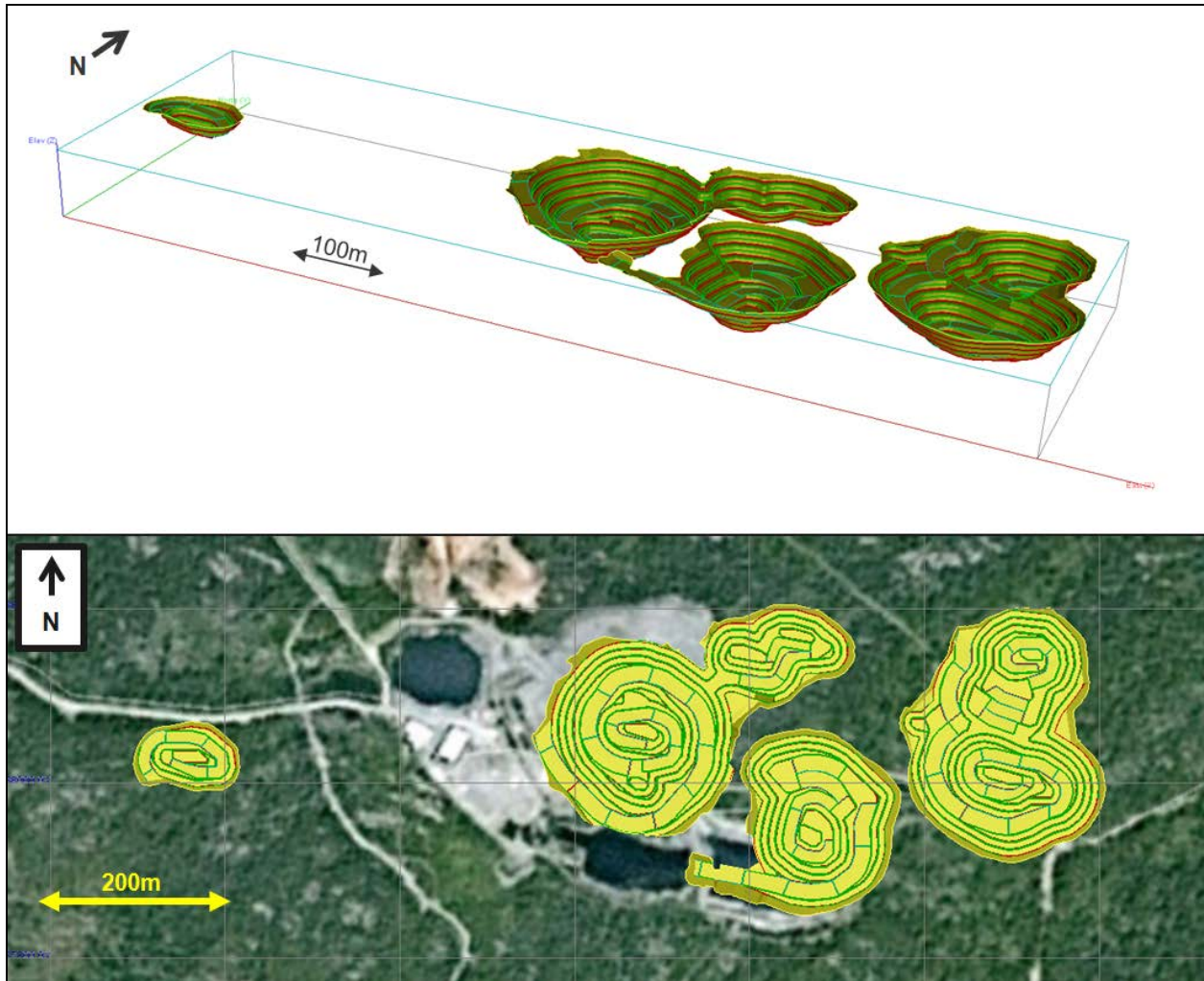

Figure 16-7: 3D and Plan view of the detailed pit

As it can be seen in Figure 16-7, four (4) pits were created. The numbers of isolated pits is lower than the optimization output. SGS decided to not consider some of them due to their high stripping ratio and their low profitability.

The in-pit haulage two-lane ramp, having a 10% slope, is designed at 18.3 m wide to accommodate two 35 tonne class mining trucks, with allocation for safety berms. This ramp will provide sufficient room for two-way traffic to maximize the truck cycle time and productivities. A single lane ramp of 13.5 m wide and having a 12.0 % slope will be used for the last benches in the pit bottom, where double lane traffic is not required. This is to minimize the overall stripping ratio of the pit. SGS tried to exit the ramps to the north sides of the pits to facilitate an easy and short access to the waste rock piles.

The dimensions of the four (4) pits are presented in the following Figures, as the in-pits resource blocks above a cut-off grade of 1.69 g/t Au.

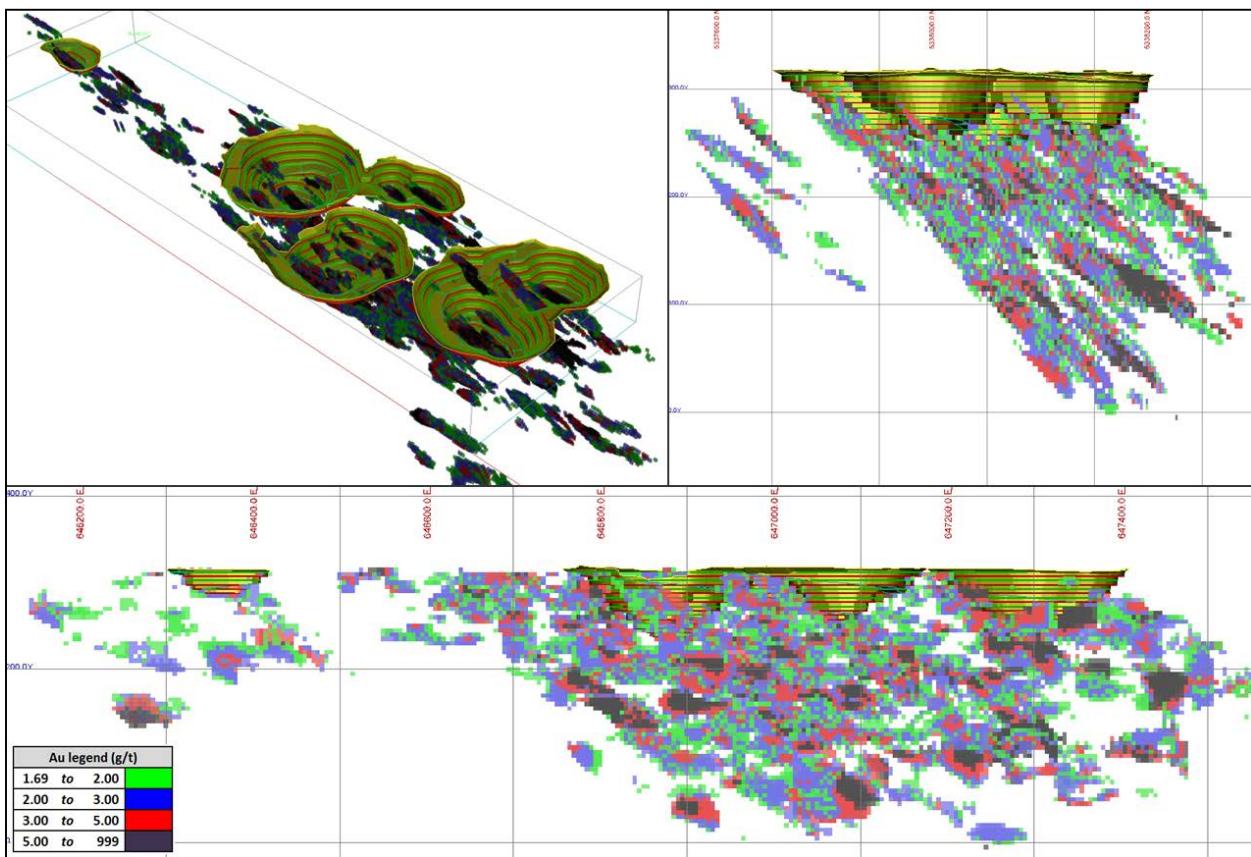
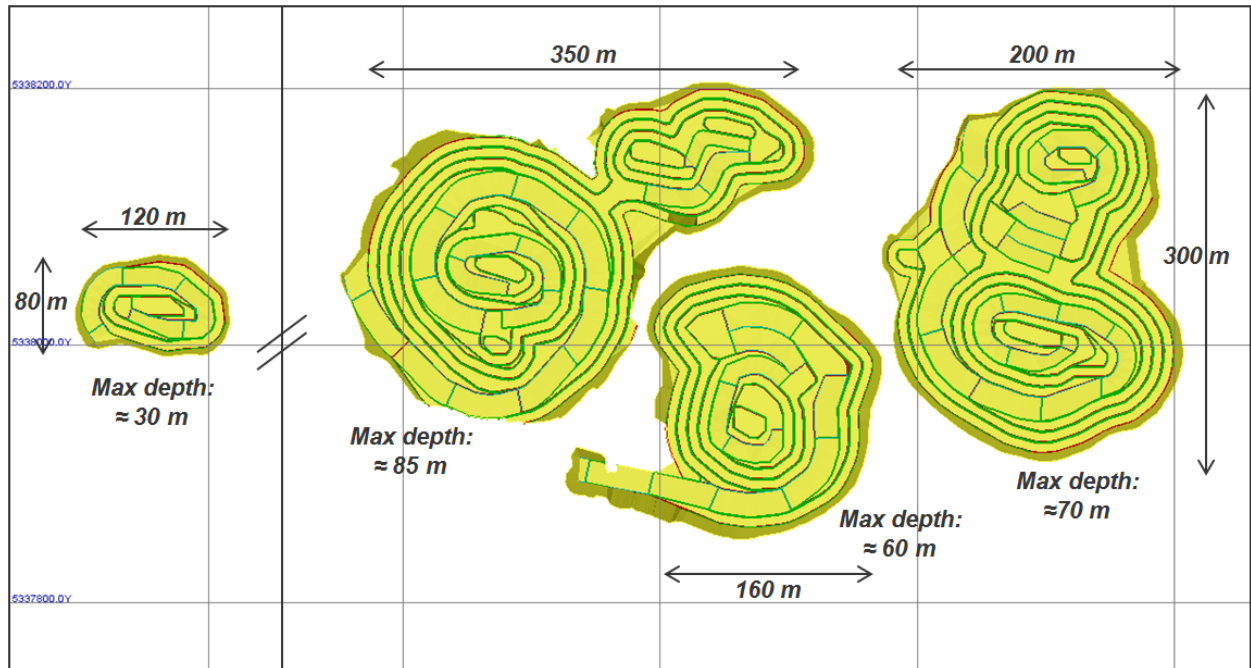

Figure 16-8: Various views of the detailed pit with block model

16.5 DILUTION AND ORE LOSS

Using the designed open-pits, SGS reviewed the estimation of the mining dilution and ore loss that was presented in section named Pit Optimization Procedure and Parameters.

SGS came to the conclusion that given the pits shapes, size and geometrical characteristics of the deposit, the mining dilution and ore loss factors have been assumed at 25.0 % at 0.0 g/t Au and 10.0 % respectively. These assumptions are based on a comparison of the characteristics of the deposit and the mining method with similar projects.

16.6 MARGINAL CUT-OFF GRADE

The marginal cut-off grade or milling cut-off grade (CoG) is used to classify the material inside the pit limits as in-pit reserve or waste. Since the material is located inside the pit, the marginal cut-off grade excludes the mining cost and corresponds to the grade required to cover the costs of processing, G&A, and other costs related to transport. The marginal cut-off is defined as:

$$\text{Resulting Marginal CoG} = \frac{\text{Total Resource Based Cost} \times (1 + \% \text{Mining Dilution})}{\text{Resulting Metal Price} \times \text{Processing Recovery}}$$

During the preparation of this PFS and with the consideration of the detailed open-pits, SGS reviewed the estimation of the total ore based cost that was presented in section named Pit Optimization Procedure and Parameters to an updated value of 57.75 \$/t (refer to section 21 for the details of the construction of this cost).

The resulting cut-off grade (CoG) is therefore equal to:

$$\text{Resulting Marginal CoG} = \frac{57.75 \text{ \$/t} \times (1 + 25 \%)}{44.89 \text{ \$/gram} \times 95 \%} = 1.69 \text{ g/t Au}$$

16.7 TONNES WITHIN PIT DESIGN

Based on the previously defined mining dilution, ore loss and marginal cut-off grade, the tonnage contained inside the pit design is presented in Table 16-2. For clarification purposes, the term pit design represents the summation of the 4 isolated pits presented previously.

Table 16-2: In-pit reserves

Material Type		Cut-off g/t Au	Material tonnes	Grade g/t Au	Au** ounces
Ore*	Proven Reserves	1.69	170,000	3.72	20,500
	Probable Reserves	1.69	399,000	4.46	57,000
	Total	1.69	569,000	4.24	77,500
Waste	Overburden		840,000		
	Waste rock		8,440,000		
In-pit Total	All		9,849,000		

* Presented as mill feed (with 25 % mining dilution and a 10% ore loss)

** Presented as mill feed (before processing recovery)

16.8 MINE DEVELOPMENT AND PRODUCTION SCHEDULE

A mine production schedule was prepared for the development and the operation of the Project. The mining production schedule for the open pit is based on a pre-stripping period of approximately 3 months. The results of the developed schedule are summarized in Table 16-3 and presented by next Figures (Figure 16-9, Figure 16-10, Figure 16-11 and Figure 16-12). Key findings include:

- Project life of 3 years, with an ore mining rate of approximately 550 tonnes per day;
- Mill feed over the Project life of 569,000 tonnes at 4.24 g/t Au;
- Gold production of 73,600 ounces.

Table 16-3: Mine Development and Production Data

		Year 0	Year 1	Year 2	Year 3	Total
Ore treated	tonnes	-	192,500	192,500	183,675	568,674
Grade	g/t	-	4.37	4.69	3.63	4.24
Processing recovery	%	-	95.00	95.00	95.00	95.00
Ounces produced	oz	-	25,669	27,556	20,361	73,585
Ore mined	tonnes	-	192,500	192,500	183,675	568,674
Overburden mined	tonnes	239,679	442,103	158,315		840,097
Waste mined	tonnes	-	2,571,864	3,449,868	2,418,110	8,439,843
Total mined	tonnes	239,679	3,206,467	3,800,683	2,601,785	9,848,614
Stripping ratio	t:t	-	15.7	18.7	13.2	16.32

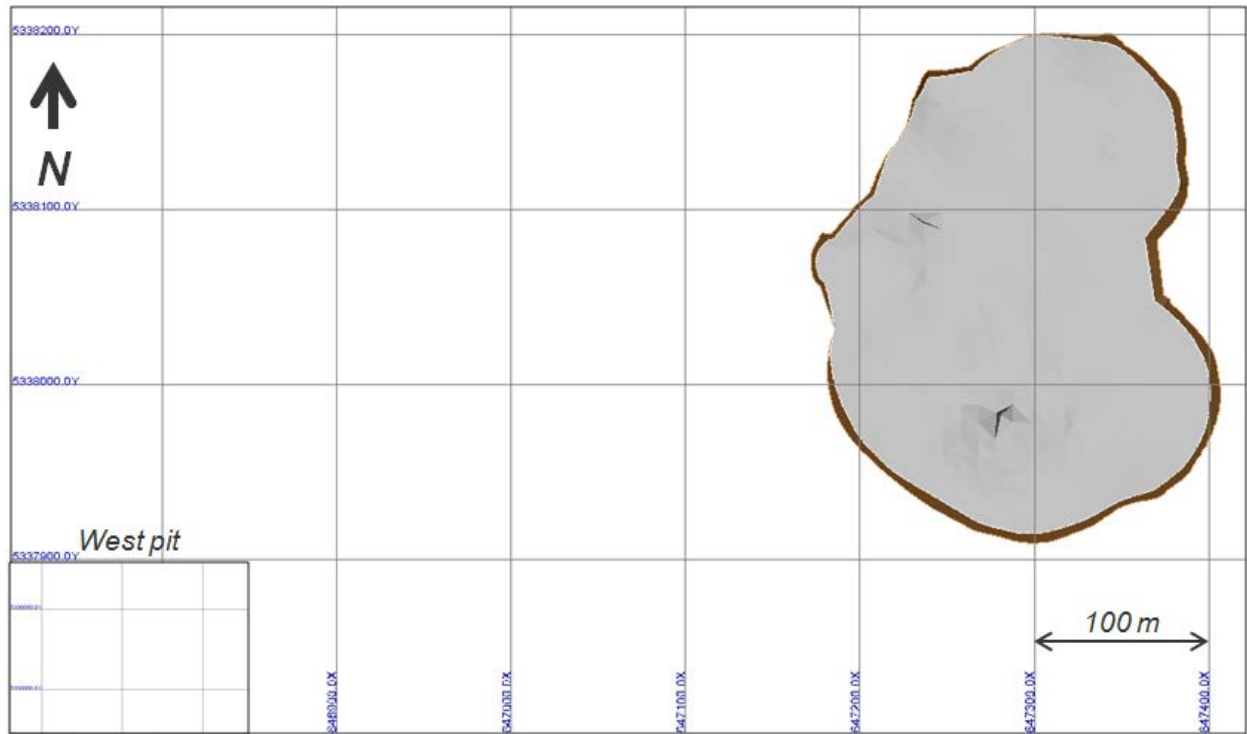

Figure 16-9: End of year 0

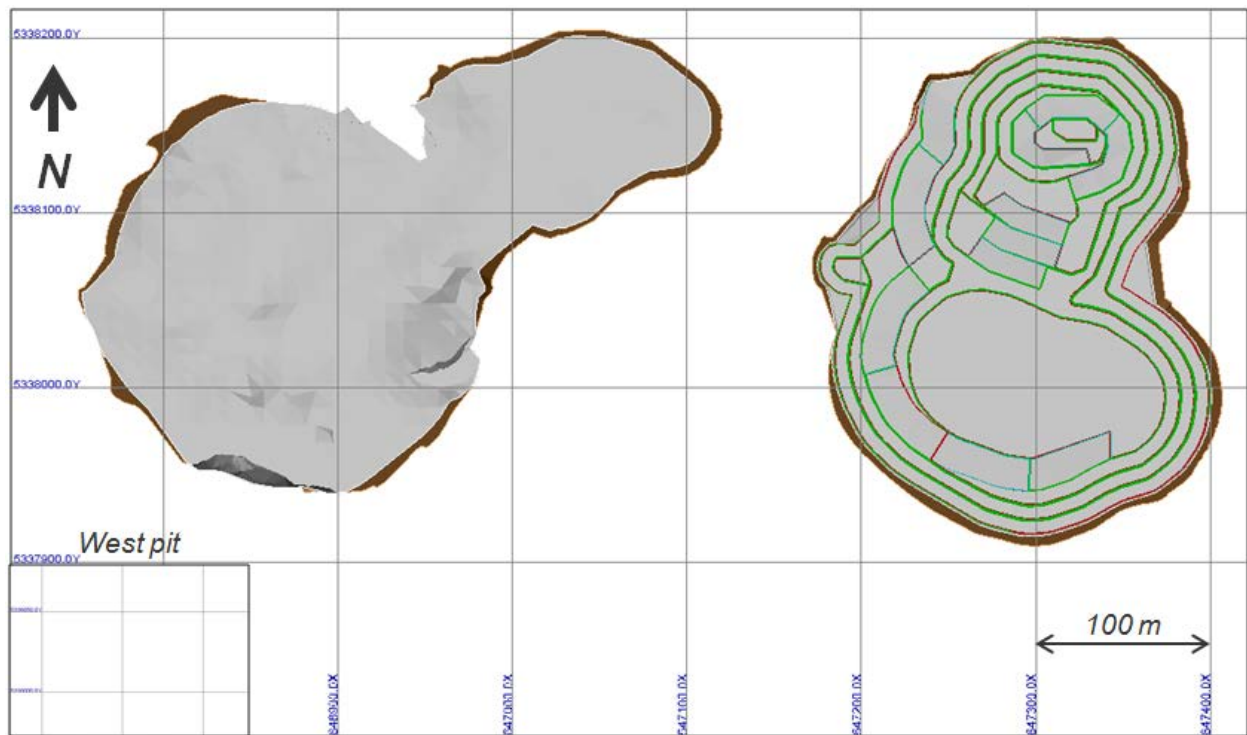

Figure 16-10: End of year 1

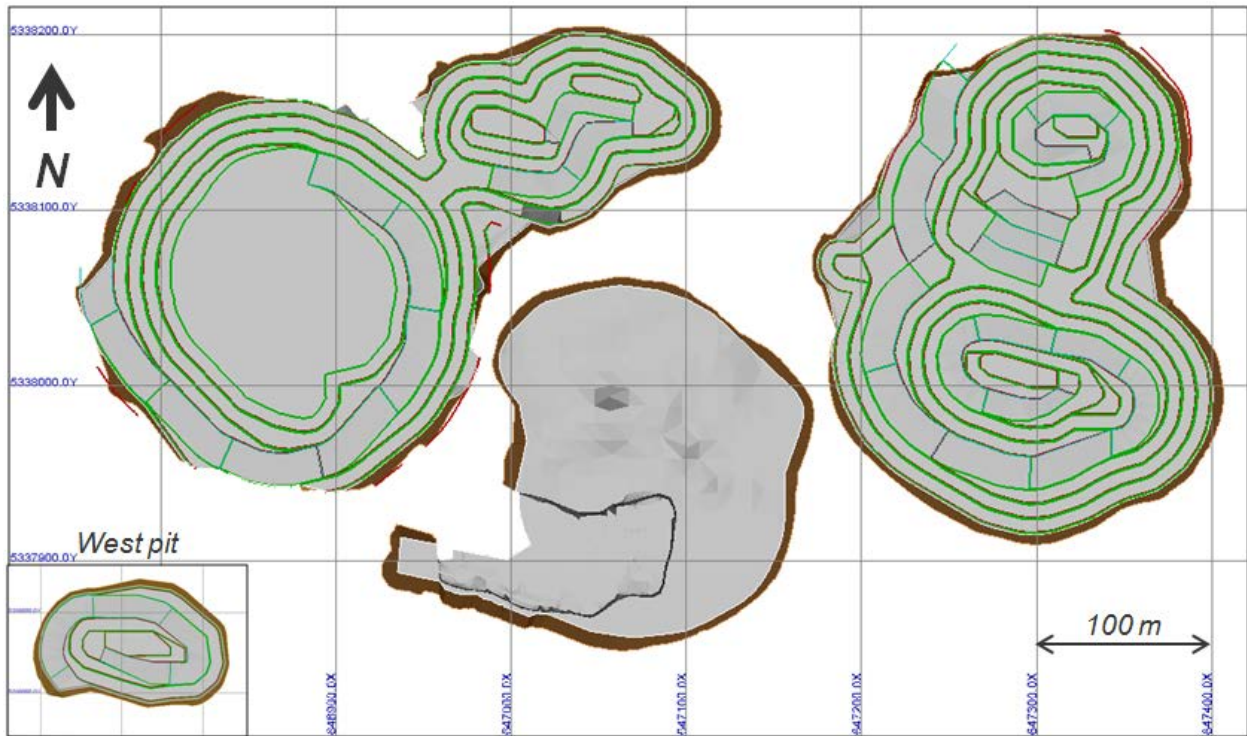

Figure 16-11: End of year 2



Figure 16-12: End of year 3

16.9 MINE OPERATIONS

The proposed schedule for the open-pit operations is based on two 8-hour shifts per day, 7 days a week and 350 days per year. The mining operations at Granada will use conventional mining methods, including drilling and blasting sequences, loading with hydraulic excavators and hauling with off-road mining trucks. The selection of two 8-hour shifts is based mainly on the fact that this schedule will avoid any possible disturbing of the neighborhood during the night.

16.9.1 DRILLING

Blast holes drilling will be performed by diesel drilling units. All holes will be drilled with a diameter of 5.0 inch (12.7 cm), on a 4.0 m x 4.0 m pattern. Due to the overall average low dip of the mineralized zones, between 35° to 50°, the working bench height is planned at 5.0 m. Table 16-4 is a summary of the parameters selected for the blast hole drilling.

Table 16-4: Drilling Parameters & Assumptions

Parameters	Units	Value
Holes Depth	<i>m</i>	6.00
Penetration Rate	<i>m/min</i>	0.55
Grade Control Sampling Time	<i>min</i>	2.00
Move and Align Time	<i>min</i>	2.00
Total Time per Hole	<i>min</i>	14.91
Holes per Hour	<i>holes</i>	4.02
Average Drilling Rate	<i>m/h</i>	24.15

The total number of drills required for the maximum production is estimated at one unit, as shown in the Table 16-5, for a daily tonnage varying from 7,500 to 10,500 tonnes per day.

Table 16-5: Drilling data

Parameters	Units	Year 1	Year 2	Year 3
Maximum Daily Tonnage (ore + waste)	<i>tonnes</i>	8,000	10,500	7,500
Burden	<i>m</i>	4.0	4.0	4.0
Spacing	<i>m</i>	4.0	4.0	4.0
Depth (Bench height)	<i>m</i>	5.0	5.0	5.0
Sub-drilling	<i>m</i>	1.0	1.0	1.0
Rock density (average)	<i>t/m³</i>	2.7	2.7	2.7
Tonnes per holes	<i>t/hole</i>	216.8	216.8	216.8
Tonnes per drilled meters	<i>t/m</i>	36.1	36.1	36.1
Required tonnes per day	<i>tpd</i>	8,000	10,500	7,500
Required meters per day	<i>mpd</i>	221.4	290.6	207.6
Required holes per day	<i>holes</i>	36.9	48.4	34.6
Average drilling rate	<i>m/h</i>	24.1	24.1	24.1
Required drilling time per day	<i>hours</i>	9.2	12.0	8.6
Number of drilling unit required*	<i>unit</i>	0.75	0.99	0.71
Number of drilling unit required (rounded)	<i>unit</i>	1.0	1.0	1.0

*Based on a 95% mechanical availability and 80% work efficiency

16.9.2 BLASTING

This operation will be under a subcontract with an explosive contractor (supplier) that will take control of all blasting operations, explosive and detonators supply and loading and connecting the blasts. The project will benefit from being close to major suppliers with blasting supplies and experience. The regular powder factor is estimated at 0.30 kg/tonne, both in ore and waste, using emulsion type explosive having a density of 1.28 g/cm³. Table 16-6 summarizes the parameters retained for the production estimations.

Table 16-6: Blasting parameters

Parameters	Units	Value
Tonnes per hole	<i>tonnes</i>	216.8
Hole depth	<i>m</i>	6.0
Collar	<i>m</i>	2.00
Active column	<i>m</i>	4.00
Hole diameter	<i>"</i>	5.0
Hole diameter	<i>cm</i>	12.7
Emulsion density	<i>g/cc</i>	1.28
Qty emulsion per hole	<i>kg</i>	65
Powder factor	<i>kg/tonne</i>	0.30

Emulsion-type explosive were selected due to his good water resistance and its better overall performance when compared to other explosives like the Amex products. Non electric detonators, like the Nonel type are recommended. Blasting results will determine if electronic detonators should be preferred.

16.9.3 FLEET REQUIREMENTS

Production will be accomplished using a fleet of 35 tonnes capacity haul trucks and hydraulic shovels with a 5 tonnes bucket capacity. This fleet combination should allow for 5-6 pass loading of trucks hauling mineralized material and waste for a loading time estimated at 3.5 minutes. The requirements for the primary mining equipment include; a fleet of drills haul trucks, shovels, and one supporting wheel loader, which are based on the haul distances, equipment availability, utilization, and overall productivity data. Availability profiles for major equipment have been estimated using SGS's database and internal operational experience.

The truck fleet consists of units having a payload capacity of 35 tonnes (Volvo A35 or equivalent). A maximum of seven (7) trucks will be necessary to support the mine productivity at year 2, along with the waste removal schedule (rock and overburden). Operating truck requirements were determined using the appropriate operating time parameters, fill factors, haulage distances and cycle times, and tonnes to be moved by material type. The truck fleet size was calculated using a mechanical availability of 90% and an efficiency of 85 %. The gross operating hours used for the operating truck calculation are based on a 2 x 8 hours shift work schedule and depend upon the variable mechanical availability.

The proposed hydraulic shovel fleet consists of 5 tonnes front-end configured units for loading the blasted ore, waste rock, and overburden. Annual shovel productivity was determined using the appropriate operating time parameters, fill factors, material properties, and bucket capacities. Two shovels will be required for the entire duration of the operation. In addition, one wheel loader will assist in the loading of ROM in cases where the main loading equipment is temporarily unavailable or when temporary additional loading production is required.

One operating drill is also required to satisfy production.

One tractor will be required in order to place material on the waste dumps and to assist in the open pits when required.

Additional support equipment will also be required such water truck, grader, etc.

For a complete list of all primary, secondary and auxiliary equipment, see Table 16-7.

Table 16-7: Mining fleet

Mining Equipment	Model (reference)	Quantity
Production drill	DrillACopco AC-ROC D55152	1
Excavator	Volvo 460	2
Excavator	CAT 336	1
Wheel loader	CAT 980H	1
Haul truck	Volvo A35 (35 tonnes)	4-7
Tractor	Cat D6 dozer	1
Water truck	To be selected (+/- 5,000 gal.)	1
Grader	Cat 12M Grader	1
Pick-ups	To be selected	5
Mechanical truck	To be selected	1

16.9.4 MANPOWER REQUIREMENTS

The manpower requirements for the mine are divided into two categories: hourly operations and staff personnel. A full list of the personnel over the life of the mine can be seen in the Table 16-8 shown below.

Table 16-8: Hourly and staff personnel

Category		Year -1	Year 1	Year 2	Year 3
Mine - Operations	Drilling	-	3	4	3
	Blasting	-	-	1	-
	Mucking	2	6	6	6
	Hauling	6	15	24	15
	Services	2	8	8	8
Mine - Supervision & Others	Mine superintendant	1	1	1	1
	Assistant shiftboss	1	1	1	1
	Mine clerk	1	1	1	1
	Mechanic	2	6	6	6
	Mine helper	-	1	1	1
Mine Engineering	Chief engineer	1	1	1	1
	Surveyor	1	1	1	1
	Mapping technician	-	1	1	1
Geology	Chief geologist	1	1	1	1
	Assistant geologist	1	1	1	1
	Technician	1	1	1	1
Administration	Mine manager	1	1	1	1
	Administrative assistant	1	1	1	1
	Accountant clerk	1	1	1	1
	Environmental technician	1	1	1	1
	Warehouse responsible	1	1	1	1
	Human resource	1	2	2	2
	Driver	-	1	1	1
Total		26	56	67	56

Notes:

The reason behind the small mechanical crew is due to proximity of the services available in Rouyn-Noranda. During peak periods, external mechanical would be requested to assist.

16.10 PIT DEWATERING

According to the Roche Ltd Consulting Group preliminary report, dated October 02, 2013, a constant pumping water flow rate of 1,240m³/day (228 US GPM) will maintain the future open pits dry. For the PFS estimation of dewatering costs and pump purchase a maximum water flow rate of 2,500m³/day was retained, which represents twice the estimated constant flow rate. In accordance to the Roche study, the Bruère River was chosen as the discharge area. This area is located at a distance of 1,600 m north east and about 35 m below the existing and future pits. To proceed with the safe dewatering of the production it is recommended to have a spare pump for every active pump.

It is assumed that the water lines and accessories used during the existing pits dewatering will be left in place for the future pits production. The dewatering is planned to be done with submersible type pumps only.

16.11 ORE LOADING AND TRANSPORT

As discussed previously, ore material will be put on the temporary stockpile (Pad capacity of 15,000 to 20,000 t) on-site for short period of time as the main ore stockpile should be located at IMG gold milling facility (Pad capacity between 60,000 to 70,000 t). A transport contractor will take care of transporting the run-of-mine ore to the selected processing plant by highway trucks (using 35 tonnes trucks). The distance is estimated at 46 km Pad to Pad and an estimated traveling time of one hour one direction. The detailed finale schedule is not completed yet. GBB with its consultants have contacted the School board and summer camp responsible of the town of Rouyn-Noranda to address traffic time concerns. The company do not intend to haul material during the night as well as there is limited to no traffic haulage during kids arrival and departure of the Granada school. Alternative routes have been studied and the presented path is the one which meets regulations to the provincial and municipal level. The path has been studied with the technical counsel of the town of Rouyn-Noranda.

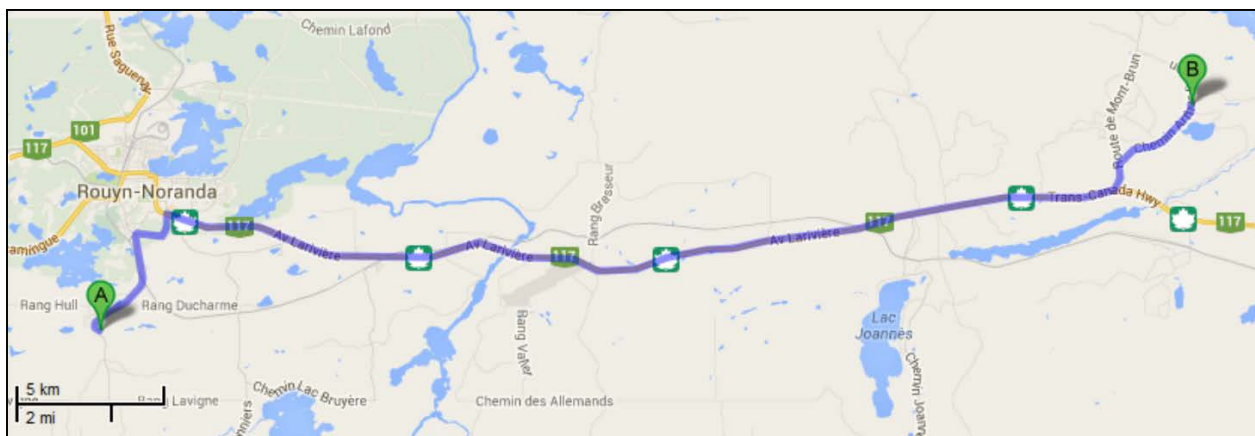

Figure 16-13: Ore transport from mine to processing plant

Moreover there are actually discussions with the town of Rouyn technical team on modification of a small portion of the identified route at Granada village. This change would be made to accommodate concerns of resident of the Granada village about long term haulage trucks in the village. After second public meeting GoldMinds for GBB has identified an alternative route where trucks could by-pass the village of Granada and avoid circulation near the school. This modified path is currently under evaluation and discussion with the town of Rouyn and would not require significant investment.

The project mining and haulage schedule which subject to signature of the final custom milling agreement and reception of the Certificate of Authorisation from the MDDELCC is shown in Figure 16-14.

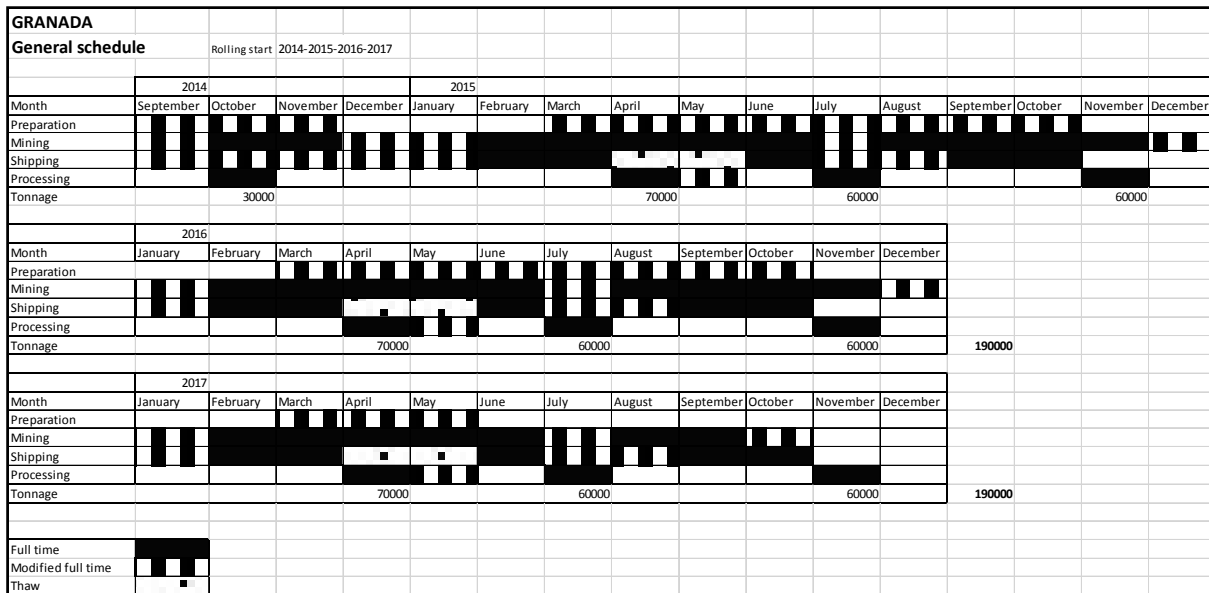

Figure 16-14: Project mining and haulage schedule

16.12 OLD UNDERGROUND EXCAVATIONS

It has been since 1930 that the Granada project is sporadically mined. Consequently, old underground excavations are present and need to be considered if mining is re-started.

The first pit is in a Greenfield zone where no underground mining has proceed. It is scheduled to proceed with 3D scanning of openings and survey once water level allows access to the openings. Old underground drift location have been put in plan but exact position are not considered exact for the mining operation and the company should complete a detailed survey once access is possible using laser scanner, surface survey with GPR to model openings.

Procedures will have to be put in place for the accurate survey of the openings before getting into their vicinity. As the mining width of the old time is relatively thin and no huge openings are present in documents, the procedure should be relatively simple and limited ore drop to the level should occur.

It is important to mention that as per existing information only a portion of the bottom of the pit to the west should cross small underground openings.

17 Recovery Method

17.1 GENERAL

At least for some time, all ore from the Gold Bullion project will be processed in batches at the Iamgold-Doyon mill (IMG) (Figure 17-1). The mill originally built in the 1970's was completely refurbished between 2011 and 2013 in order to efficiently process the Westwood ore.

The actual scenario for Gold Bullion (GBB) is to mine by open pit between 175,000 and 200,000 tonnes of ore per year at a rate of 550 tonnes per day and have the ore processed at IMG. The IMG mill has ample capacity to process some 2,420 tonnes of ore from the Westwood Mine every day. But for the first two years, due to mine development, the ore from the Westwood Mine will be processed at a rate of only 600,000 tpy or some 2,380 tpd, five days per week. Subsequently, the tonnage will eventually increase gradually to reach the annual nominal capacity of 850,000 tpy at the beginning of the fourth year. In the mean time the Gold Bullion ore will permit to close part of the gap between the Westwood Mine throughput and the IMG mill nominal capacity of 3,200 tpd.

The original scenario between GBB and IMG was in line with 50,000 tonne batches, every 63 to 64 days IMG would stop milling the Westwood ore for a period of 15 days and will process the GBB ore at a rate of 2400 tpd, 24 hours per day, 7 days per week. To ensure that the IMG mill never runs short of ore during the 15 days allotted to GBB, the mill will stop processing the Westwood ore only when at least 30,000 tonnes of the GBB ore will be stockpiled at Doyon and another 20,000 tonnes stockpiled at Granada.

As per recent discussion between GBB and IMG at the moment of completing this report, 3 periods to process the ore in batches are now identified. A minimum of 30,000 tonnes still exist, the new batches aimed at processing 60,000 to 70,000 tonnes batches in April, July & November. This to avoid any freezing muck issues in the ore bins. The general schedule is presented in previous section 16.2.

In order for GBB and IMG to settle for the gold and silver recovered from GBB's ore, in addition to the tonnage calculation, the normal daily mill sampling, the weighing and the analysing of the doré bars, the mill will be surveyed and gold inventory will be taken all over the mill at the beginning and end of each batches.

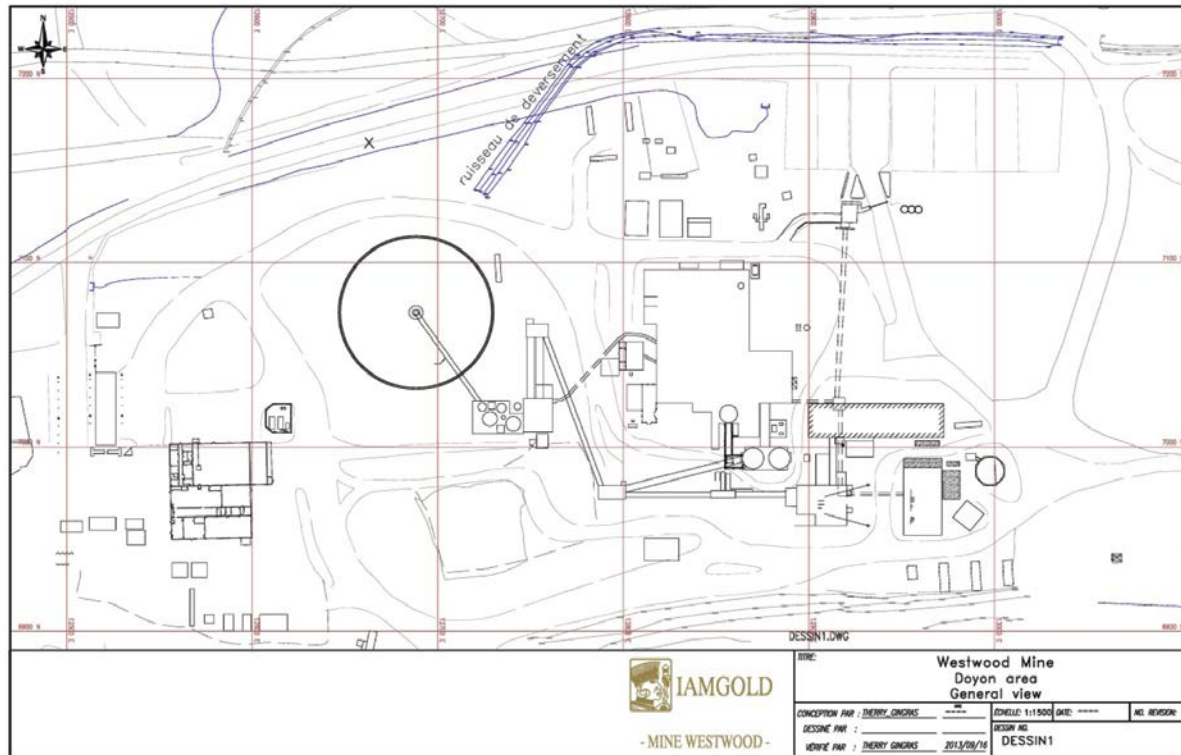

Figure 17-1: Doyon site – Surface plan

17.2 ORE HANDLING – CRUSHING – GRINDING - GRAVITY

The ore having an average grade of 4.24 g/t will be hauled by trucks on a distance of approximately 43 km from the Granada mine to IMG and discharged on a dedicated pad nearby the crusher house. When convenient, the ore will be dumped directly on the 27" aperture crusher hopper grizzly by the incoming trucks. If not, the ore will be retrieved from the pad and delivered to the surface crusher with a front end loader. Oversize will be left aside or break with the existing hydraulic rock breaker. Crushing is done with a 1.07 m x 1.22 m jaw crusher and the crushed ore is conveyed to the two 2,800 tonne mill ore bins.

Grinding of the Granada ore will be done using the 2,700 HP SAG mill in close circuit with a primary battery of 500 mm hydrocyclones. Cyclones overflow feeds a 1,000 HP ball mill in close circuit with a secondary battery of 600 mm hydrocyclones. Because of the smaller size of the Knelson concentrator (30"), it is possible that only a portion of the secondary hydrocyclones underflow will pass by the gravity separator to be followed by a Gemini shaking table. The other portion, or the whole gravity separator tailings, as the case may be, will report to the 1,000 HP ball mill. The gravity circuit concentrate will go directly to the refinery. Secondary cyclone overflow reports by gravity to the 27 m leaching thickener.

For the purpose of this report, it is assumed that the Granada ore grinding characteristics are similar to the Westwood and Doyon ores. The targeted grinding size is 80% passing 74 microns (200 mesh).

(Drawing GR 2014-01)² APPENDIX 2

² Mill flowsheets are included less for their exactitude but to give an idea of the mass and water balance.

17.3 CARBON IN LEACH – CARBON IN PULP

The existing leaching circuit remained the same as it was when Doyon was processing its own ore. The circuit has a 60-hour retention time at the mill nominal feed rate of 3,200 tpd. Since the Granada ore needs only 48 hours to get +95% gold dissolution, in order not to over cyanide and risking to reprecipitate the gold in the in the last leaching tanks, tanks 155 and 160 may be bypassed. The circuit will thus comprise 5 primary and 2 secondary CIL tanks followed by 5 CIP tanks. Loaded carbon is screened and reports to the loaded carbon tank. Leaching tails undergo the cyanide destruction circuit.

(Drawing GR 2014-02) APPENDIX 2

17.4 CARBON ELUTION – REFINING

The carbon elution – refining circuit comprises mainly a loaded carbon tank, an acid wash tank, a carbon strip vessel, a bank of electrowinning cells and an induction furnace. Stripped carbon is reactivated in a horizontal kiln, quenched and classified. Classifier oversize is ready to be reused while very fine carbon particles are filtered in a filter press and sent to the Xstrata Horne smelter.

(Drawing GR 2014-03) APPENDIX 2

17.5 CYANIDE DESTRUCTION – DESULFURIZATION - TAILINGS

The tailings from the CIP circuit will be treated in the mill SO₂-AIR cyanide destruction plant to eliminate the cyanide. The cyanide destruction circuit comprises mainly two 250 m³ reactors in parallel in which SO₂ is added probably on the form of sodium bisulphite. Air is injected to the reactors with a blower. If needed, some lime and copper sulfate could be added to the reactors.

If required by IMG, prior to be sent to the tailings ponds the mill tailings will be desulfurized. Main desulfurization machinery includes two 2.8 m x 3 m conditioners, one 20 m³ rougher unit cell and 2 banks of four DR-180 scavenger flotation cells. Concentrate will be pumped to the Westwood 20 m paste backfill thickener while the desulfurization tailings will report to the main tailings pond.

The flotation (desulfurization) tailings will be pumped to the tailings pond 3 West and allowed to settle. Supernatant water will then be pumped to the polishing pond 3 East. Clear water from the polishing pond will finally be pumped to the process water reservoir.

(Drawing GR2014 – 04) APPENDIX 2

17.6 GOLD RECOVERY

Based on previous metallurgical testing (See Chapter 13) it is probable that 50% of the gold will be recovered at the gravity circuit and out of the remaining 50%, another 90% will be recovered from the leaching of the gravity tailings for a total gold recovery of 95%.

17.7 GOLD PRODUCTION SETTLEMENT

Because it is not possible to avoid some ore mixing at the beginning and end of each batches, GBB an IMG will have title to and ownership of the doré bars on a pro rata basis based on the respective amounts of refined gold attributable to each of the companies.

18 Project Infrastructure

The Granada Project will require the construction of several components and facilities which will all be located at the mine site. The following section describes the major components of the required constructions and the general layout is shown in the Figure 18-1.

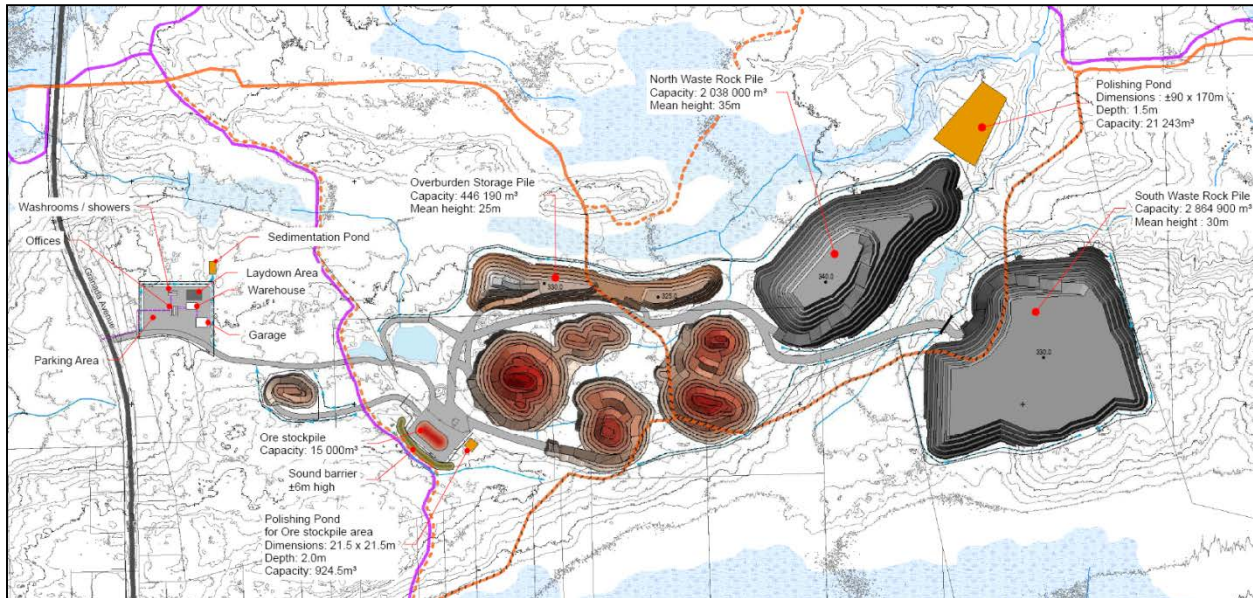

Figure 18-1: Aerial view of site layout of Granada project

18.1 PROCESSING FACILITIES

No processing facilities will be erected on site as all the ore material will be treated at an external plant. Please refer to section 17 for a complete presentation of this specific item.

18.2 OFFICES

Considering the short mine life, a series of office trailer, as shown in the Figure 18-2 below, will be used as offices. The advantage of using this kind of offices is that they are cheap to buy or they can be rented depending on the needs. Actually, two of these trailers are currently on the site and it is planned to acquire 3 others to accommodate the staff personal. In addition to the two actual trailers, a steel cladding and roofing building is currently (Figure 18-3) on site and is planned to be used for the sanitary facilities and mine dry, first aid facilities, small repair shop and secondary warehouse.



Figure 18-2: Types of offices trailers to be acquired



Figure 18-3: Existing on-site infrastructures

18.3 MECHANICAL GARAGE

A ±1,200 m² building will be used as mechanical garage (Figure 18-4). The building will a dome type structure composed of high tension galvanized steel frame and a reinforced polyethylene cover. The mechanical garage will be filled with standard mechanical tools and a lift truck will be used to manipulate heavy parts. A used oil recovery system will be built adjacent to the building. The garage will be constructed directly on compacted gravel covering a geo-textile membrane.



Figure 18-4: Example of a dome type mechanical garage

18.4 WAREHOUSE/LAYDOWN YARD

A ±1000 m² building will be used as main warehouse. The building will a dome type structure composed of high tension galvanized steel frame and a reinforced polyethylene cover. An outside area, adjacent to the warehouse building will be reserved to store large size consumables, such as drill rods, steel products, etc.

18.5 POWERLINE

A 280 m powerline extension will be required to connect the planned infrastructures to the actual power line following the Granada Avenue. This extension will remain basic with a requirement of approximately 5 wood poles and a small portable power center including transformers and output circuit of approximately 400 kW. The portable power center will be covered and will also be isolated with metallic fencing (Figure 18-5).



Figure 18-5: Example of a 500 KVA portable sub-station

18.6 EXPLOSIVES MAGAZINES

Two small explosive magazines will be required to store standard explosive accessories such as detonators and boosters. These magazines (Figure 18-6) will have to be strategically located and isolated with a berm in order to respect safety regulations. Bulk explosives will be transported by truck by an explosive contractor so there is no need for bulk storage.



Figure 18-6: Example of an explosive magazine

18.7 FUEL FARM

A 15,000 gallons fuel tank will be required on site in order to fuel the vehicles and the mining equipment. The fuel tank (Figure 18-7) will be annexed to a pumping station and an environment friendly arrangement will be built using a geo-textile membrane to contain any potential spill. The fuel tank will be fuelled from local distributors that will go on site upon request.



Figure 18-7: Example of a fuel farm arrangement

18.8 ON-SITE ROADS

An arrangement of gravel road will be built on site using waste rock coming from the mining exploitation. The roads will be built progressively depending of the mining sequence. The base of the roads will be composed of run-of-mine material and the top will covered with crushed rock. A total of approximately 1.5 km of road will be required. The width of these roads will be wide enough to accommodate 3 times the operating width of the biggest hauling equipment, so approximately 15 m (3 times 5 meters).

18.9 WASTE MATERIAL STOCKPILES

18.9.1 SLOPE PARAMETERS

The slope specifications and benching arrangements were provided by GoldMinds Geoservices Inc. Slope analysis by GoldMinds relies on presumed coarse muck size and mostly existing waste dump slope conditions which were proved stable at Granada at 45 degrees. The slopes were provided as constant values for the entire dumps (i.e. there were no sector divisions). For the foundation as previously mentioned above, most of the dumps should be sitting directly on the competent bedrock and/or overburden less than 2 meters. Waste dump stability should not be an issue at Granada. In fact overall slope configuration has been prepared not as optimizing the slope but more in reducing the slope to have a suitable slope for reclamation and long term stability.

The overburden dump is designed (Figure 18-8) as a heritage hill, but in reality most of the material will be used for reclamation purposes during the life of the project with progressive reclamation. Most of the pile will site on the Bedrock foundation or overburden less than 2 meters.

Overburden dump parameters:

- Berms: 2 meters
- Bench height: 5 meters
- Batter angle 38
- Overall angle maximum 31
- Maximum height 35 meters

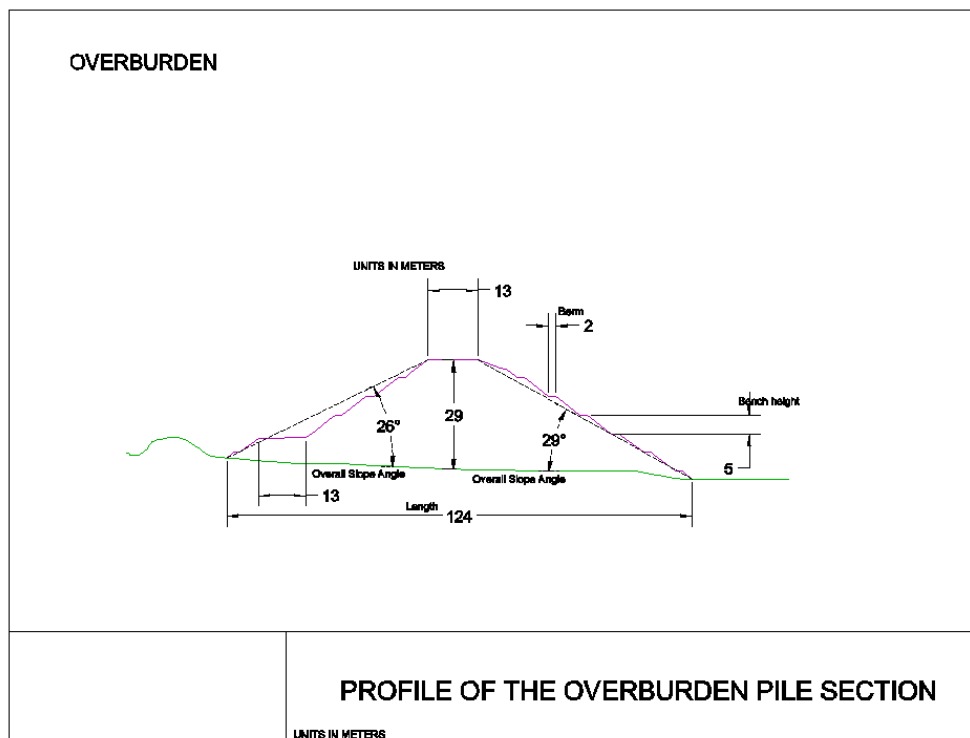

Figure 18-8: Overburden dump profile

Waste dump parameters:

- Berms: 5 meters
- Bench height: 5 meters
- Batter angle 38
- Overall angle 24
- Maximum height 45 meters

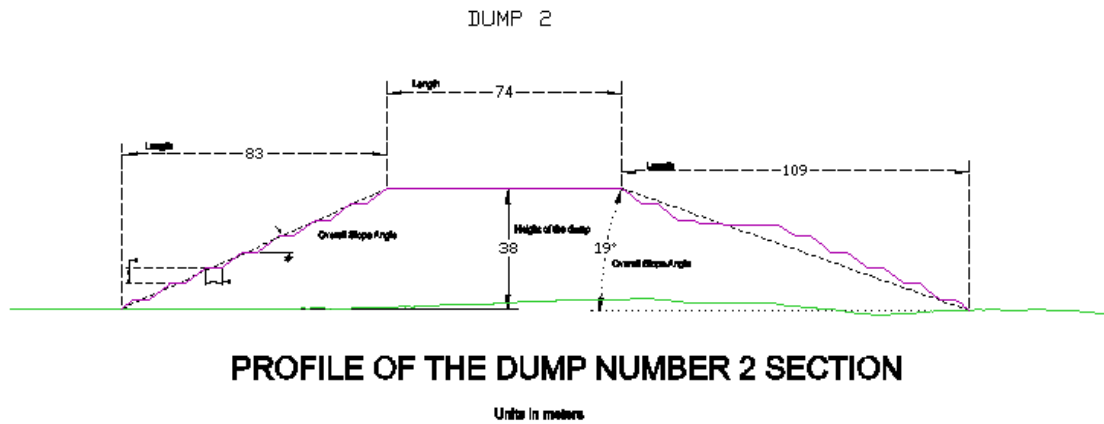
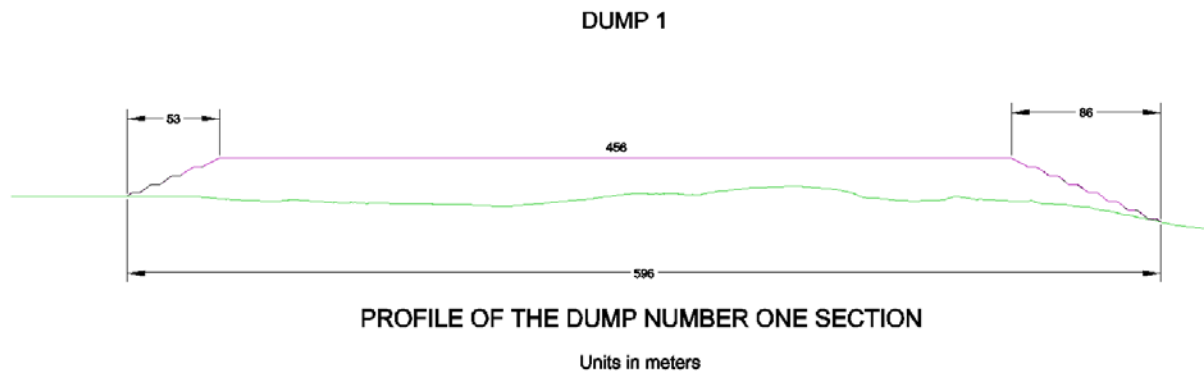

Figure 18-9: Waste Dump profiles number 1 and number 2

18.9.2 WASTE ROCK STOCKPILE

Two waste rock material stockpiles will be erected at the proximity of the open-pit. These stockpiles will be composed of rock material that does not contain enough mineralized material to be economically processed. The piles will be strategically located to minimize hauling distances, and thus the size of the mining fleet. The piles will be deservd by a 10 % access ramp having a width of 18.3 meters. The piles (refer to next Figure) will have the following configuration (Table 18-1 and Figure 18-1):

Table 18-1: Rock waste dumps (Stockpile) configuration

Characteristic	Unit	Stockpile 1	Stockpile 2
Overall slope	deg.	24.00	24.00
Face angle	deg.	38.00	38.00
Bench height	m	5.00	5.00
Berm width	m	5.00	5.00
Footprint area	m ²	172,000	91,000
Top area	m ²	109,000	12,000
Approximate dimensions	m ²	500 x 400	550 x 275
Average height	m	30.00	35.00
Maximum height	m	40.00	45.00
Capacity	m ³	2,900,000	2,030,000

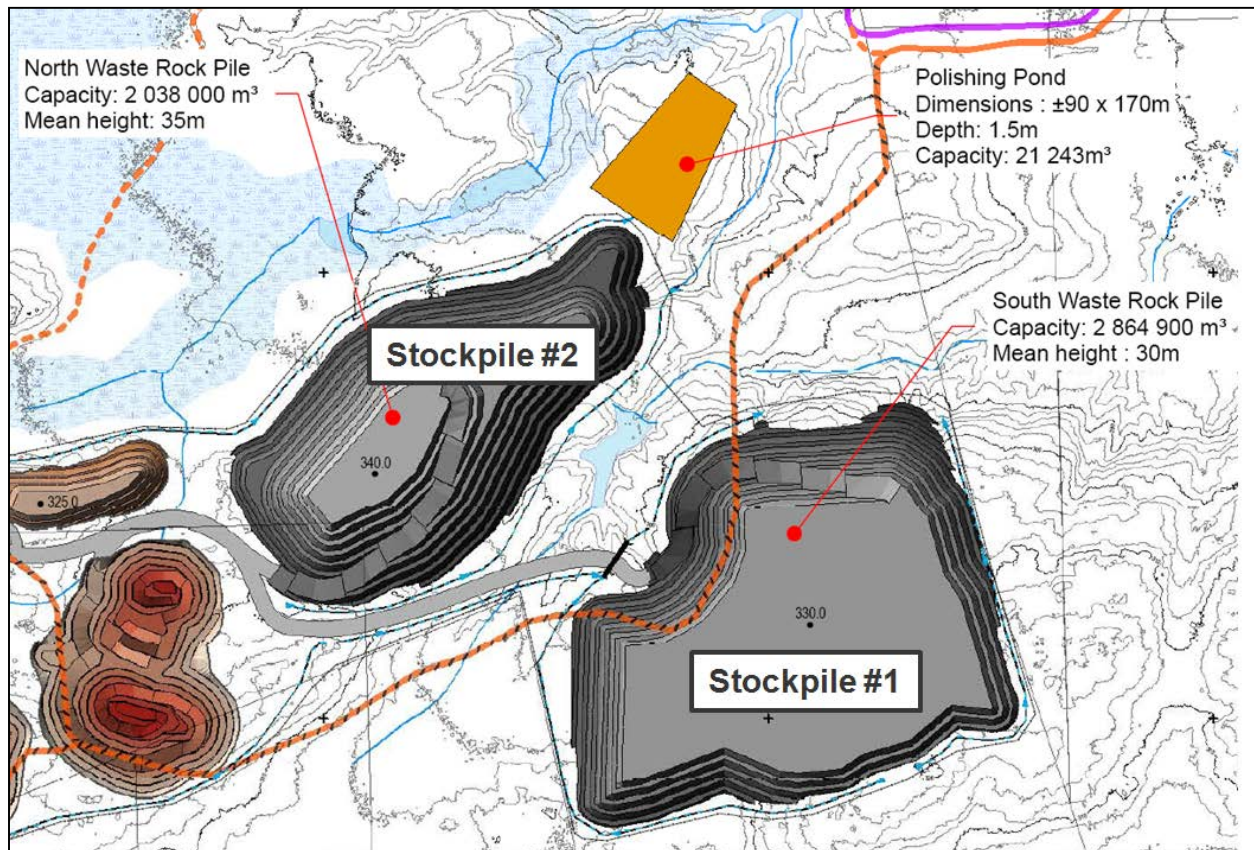

Figure 18-10: Proposed rock waste dumps locations

18.9.3 OVERBURDEN STOCKPILE

An overburden material stockpile will be erected at the North of the property. This stockpile will be primary composed of top soil material that will need to be removed in the first operational years in order to reach hard rock material containing mineralization. The pile will be strategically located to minimize hauling distances, and thus the size of the mining fleet. The pile will be designed with a 10 % access ramp having a width of 18.3 meters. The pile will have the following configuration shown in Table 18-2 and in Figure 18-11:

Table 18-2: Overburden dump configuration

Characteristic	Unit	Ovb
Overall slope	deg.	31.00
Face angle	deg.	38.00
Bench height	m	5.00
Berm width	m	2.00
Footprint area	m ²	46,000
Top area	m ²	9,000
Approximate dimensions	m ²	100 x 550
Average height	m	25.00
Maximum height	m	35.00
Capacity	m ³	450,000

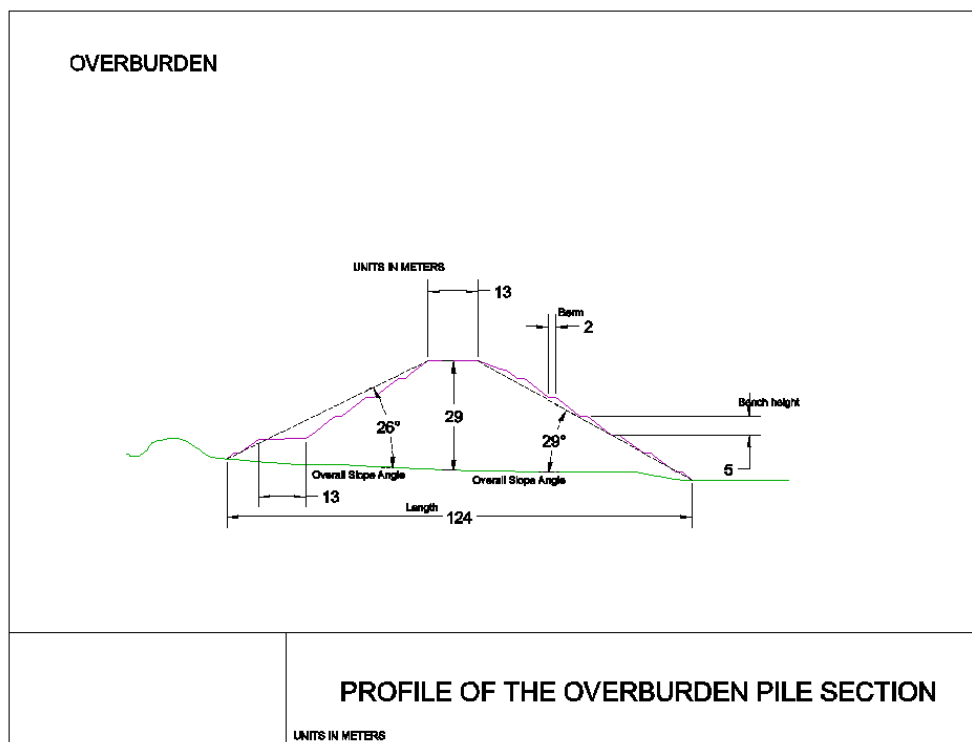

Figure 18-11: Typical section of overburden dump

18.9.4 SLOPE STABILITY ANALYSIS

The slope stability analysis has been done with reduced material properties in order to increase the level of the security factor for the long term at the beginning from the analysis of existing slope conditions at the site for the waste dump.

The analysis is based on a hill of 38 m in height with an overall slope angle presumed after reclamation of 25 degrees sitting on 1.8 meters of sand and gravel which is on bedrock. The top surface layer of organic reclamation material has not been included as non-significant for the slope stability at larger scale. The GoldMinds slope stability analysis has been performed with the software Slide developed by Rocscience.

The static analysis presents a Security Factor (SF) above 1.5 (see Figure 18-12). For the analysis with seismic activity and a saturated sand-gravel unit, the SF remains above 1.25 (see Figure 18-13). An additional forced failure with irregular path within the base with saturated overburden and light seismic activity shows a SF of 1.48 (Figure 18-14).

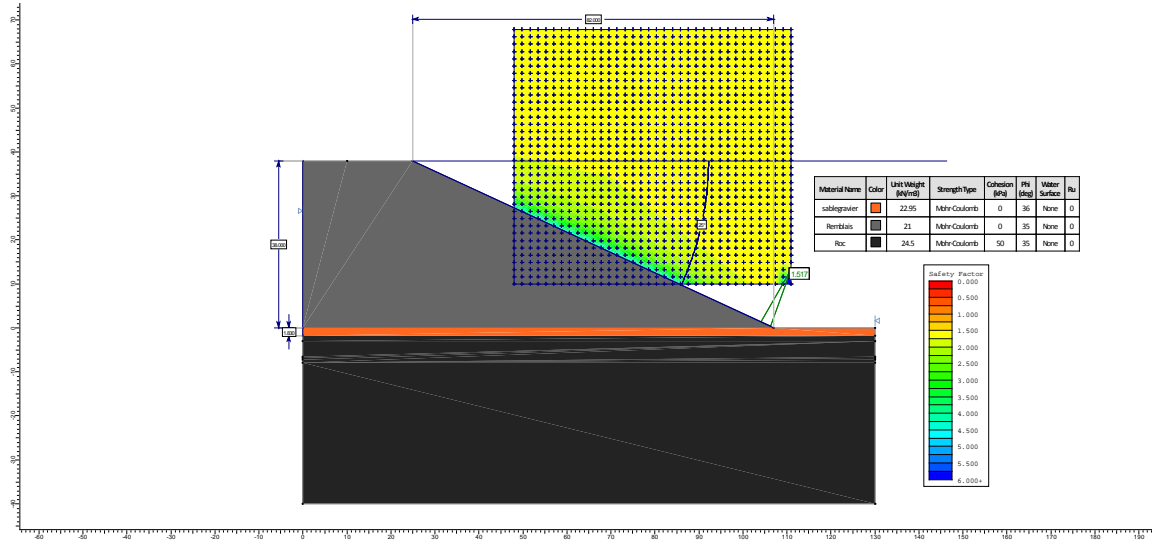

Figure 18-12: Static slope stability analysis

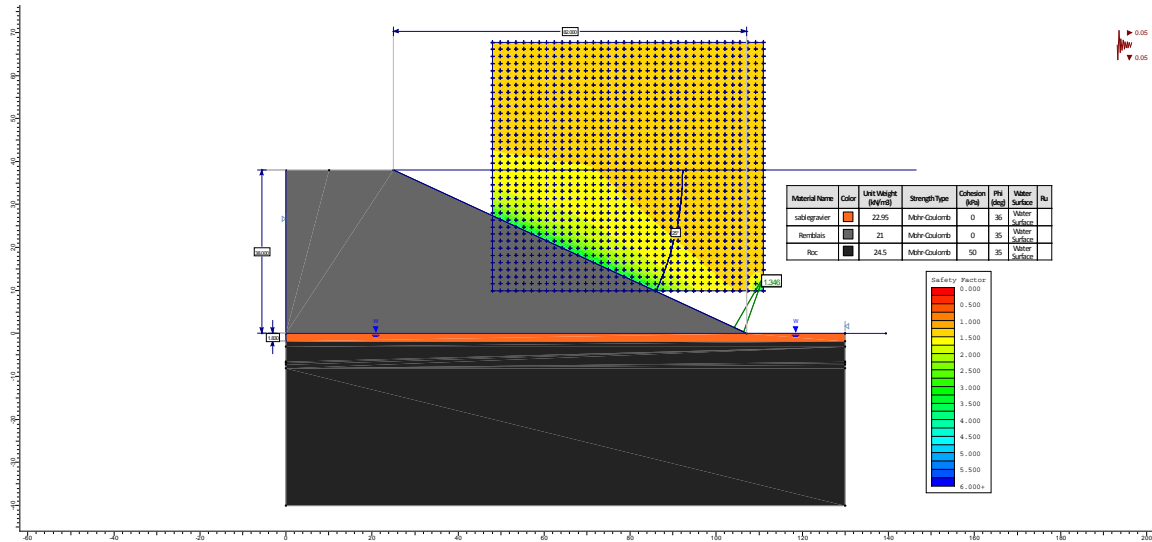

Figure 18-13: Slope stability analysis with seismic activity and saturated overburden

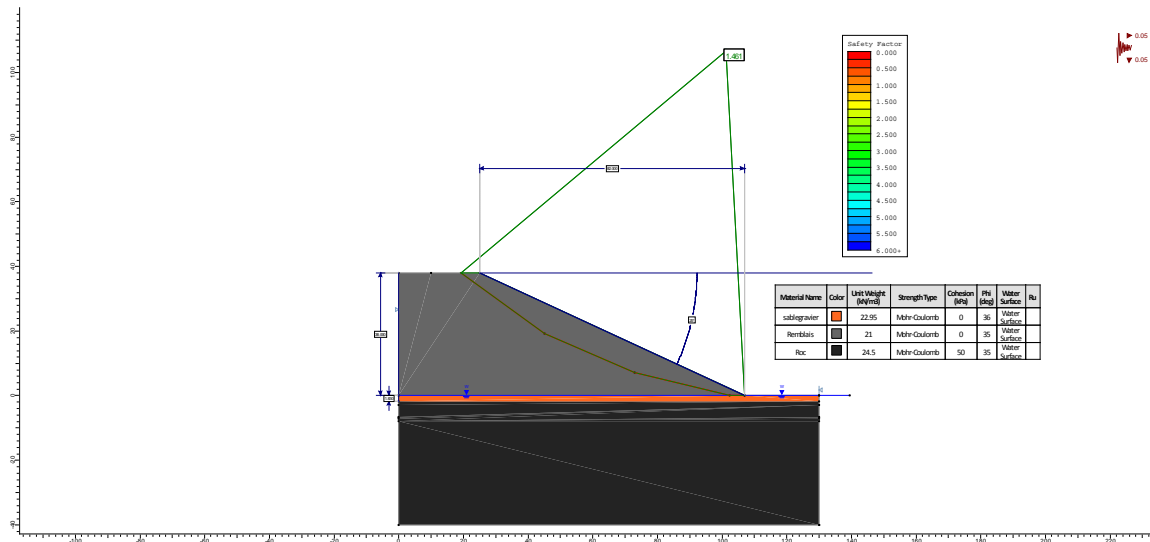

Figure 18-14: Slope stability analysis with seismic activity and saturated overburden in force failure plane

GoldMinds concludes that supplied designs for the dumps and pits are adequate in a context where surface water is controlled. Water pressure could reduce slope stability of the presented designs. It is unlikely that waste dumps will be submerged, however attention to pit walls during operation should take place and the operator should control and maintain low water pressure in the pit walls to secure long term stability.

18.10 ORE STOCKPILE PAD

An ore stockpile will be required in order to store the ore material prior to transport. Mining hauling trucks will dump the ore material to a specific location near the open-pit (the ore stockpile pad) and the transport contractor will load his highway trucks from there. The pad will be built with aggregate material covering a geo-textile membrane. The membrane will be required to contain the runoff water that will flow through the mineralized material. The area reserved for the ore stockpile will allow a quantity of approximately 15,000 tonnes stored, which is equivalent to 25 days of ore mining.

18.11 ACCESS ROAD AND PARKING

An upgrade of the actual access road will be done in order to accommodate any type of vehicles. The access road will be upgraded/built with aggregate and will have a standard width of approximately 12 meters. A parking lot will also be constructed with aggregate in order to accommodate approximately 40 vehicles. A second lane should be developed on the Granada Avenue in order to give time and room to resident to pass haulage trucks entering the Avenue on the northern direction.

18.12 WATER POND – POLISHING POND

The polishing pond has an initial capacity of approximately 21,000 cubic meters for a 1.5 meters depth, the design by GMG presents a design for approximately 40,000 cubic meters at 3 meters deep. It is located in the north east part of the project. Water pumped from the pits dewatering process and operation will travel by pipe into the basin.

The Figure 18-15 and Figure 18-16 present the preliminary design in plan view and typical profile of the dyke making the pond.

The exit design is to be completed prior to construction as a concrete sill with rock embankment (riprap) or entirely with rock embankment. The syphon approached is not considered for this design. The design for chemical addition if necessary is not included in the drawing as the system will be a solution provider based and he has not been selected yet.

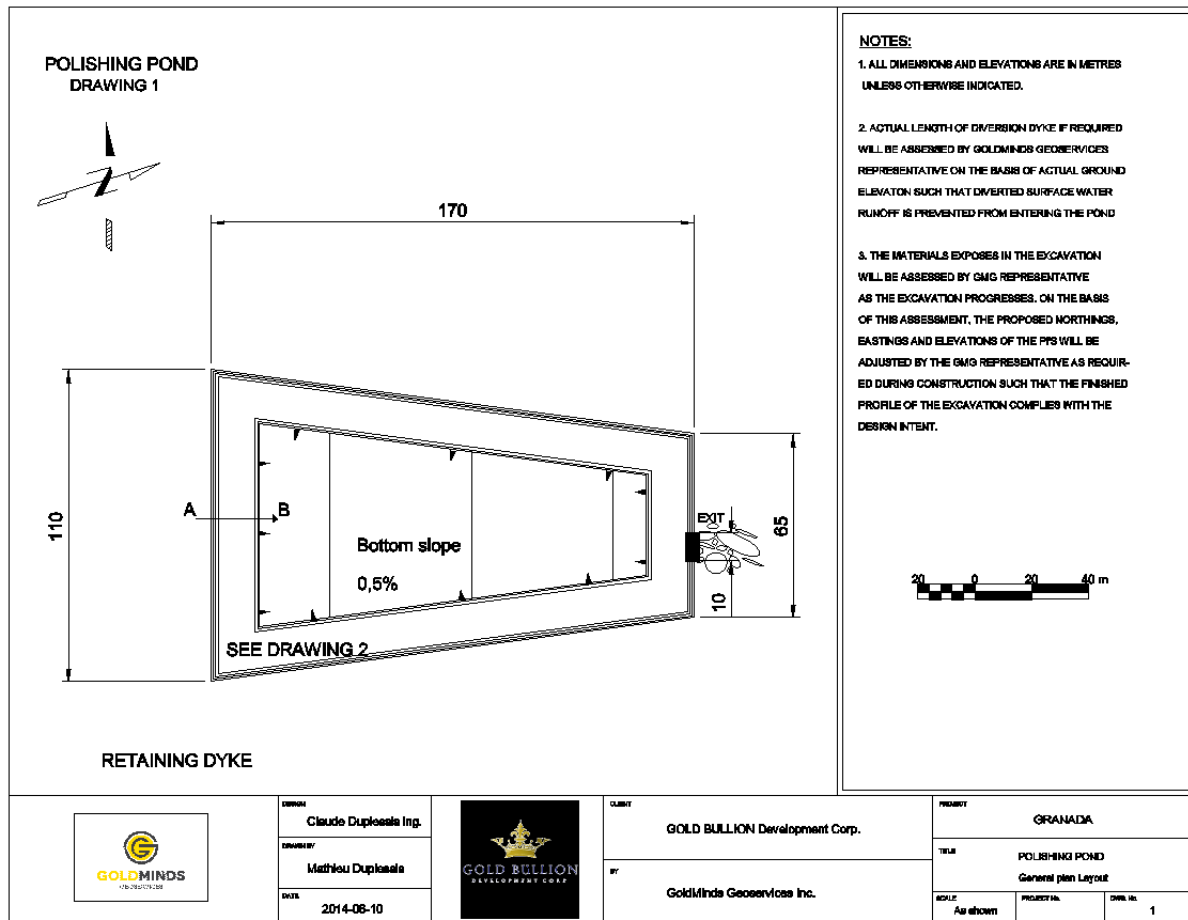

Figure 18-15: General plan layout of Polishing pond

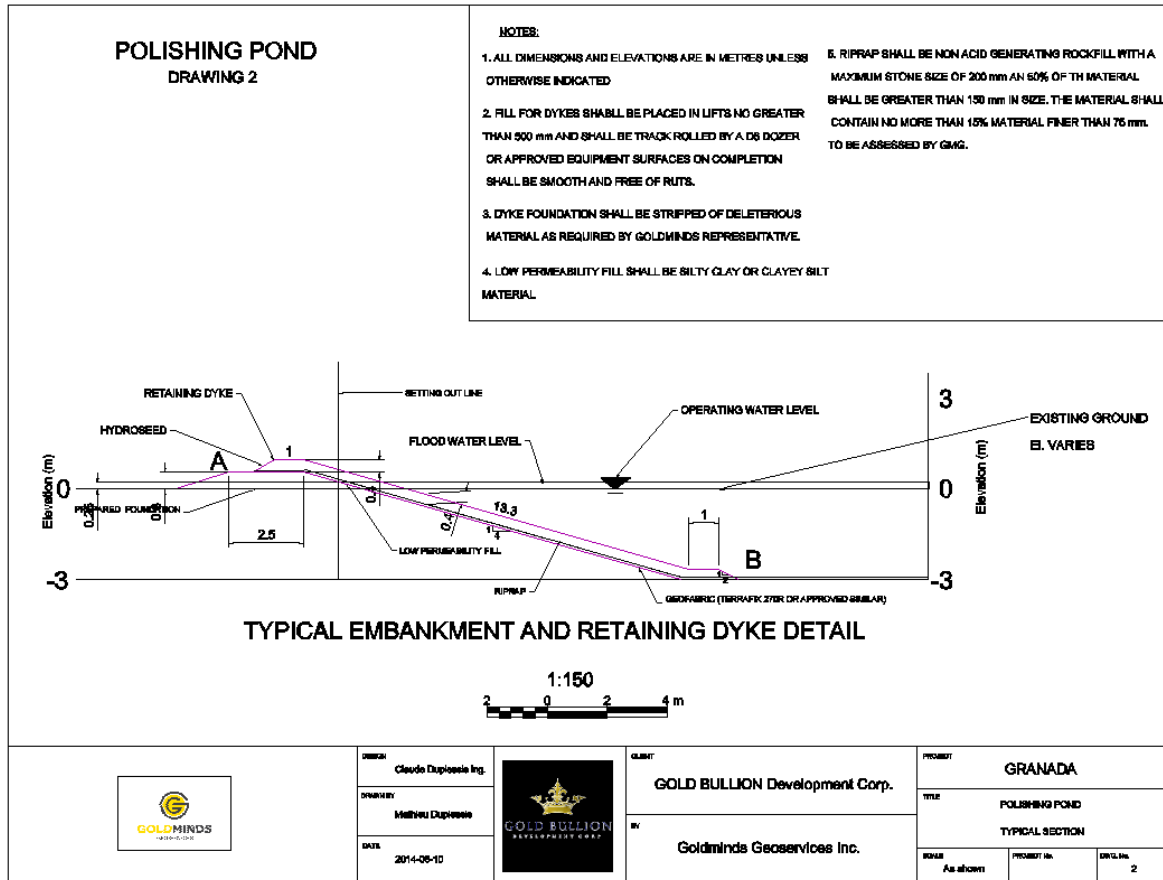

Figure 18-16: Typical section of Polishing pond

18.13 WATER SUPPLY

Drinking water will be used primarily for showers. Treatment system will be installed to treat groundwater to be pumped from a well.

19 Market Studies and Contracts

At this date, Gold Bullion does not have a contract with a refinery to treat (and pay for) its anticipated gold production from the Granada Project. However as per custom milling agreement for metal balance and gold refining, the production will be refined at the same place as lamgold Westwood production unless there is a change.

G gold market is categorized as an open-market and for the purpose of this study, SGS made the assumption that Gold Bullion will sell all its production to regular gold buyers. The 14 years trend in Figure 19-1 shows average gold price has significantly increased from the year 2000. After reaching stellar price per ounce in the 1800US\$/Oz the recent years price has stayed in the 1200 to 1400US\$/Oz range.

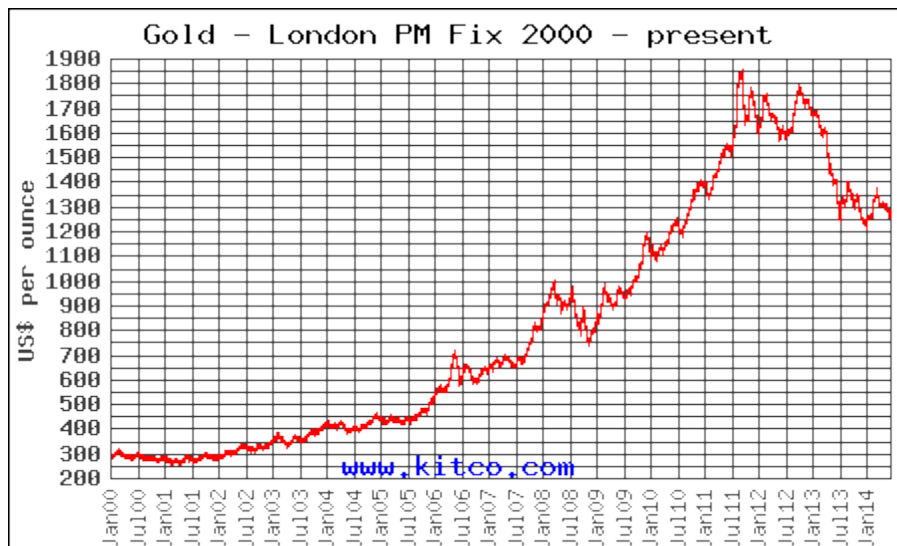

Figure 19-1: Gold price chart (2000-2014)

The gold metal bullions and bars can be sold on spot market or by contract. The author is not aware of any specific contract at the moment of completing this technical report. Historically the precious metals price retained in economical studies was the average spot prices of the last three years, which is made of 1572US\$/Oz for 2011, 1669US\$/Oz for 2012 and 1411US\$/Oz for 2013 complete years, for 2014 up to now average is 1289US \$/oz Au, as shown below in Figure 19-2, Figure 19-3, Figure 19-4, and Figure 19-5 from Kitco. The 3 years average 2011-2013 gives 1550 US\$/Oz. Adding the 2014 as a full year weight, would bring the average gold price to 1485 US\$/Oz.

Gold Bullion management has required SGS Geostat to present a robust rolling start and for this reason the gold price per ounce of 1260US\$/Oz was selected. As the mine is in Canada, exchange rate of 0.9 US to Can was used. The gold base price of the study is Can\$1400/Oz of Au.

The graph of the 2014 US\$ Gold price shows relative stability for the first half of the year as shown in Figure 19-6.



GOLD 2011 London PM Fix -USD												
	Jan	Feb	Mar	Apr	May	Jun	Jul	Aug	Sep	Oct	Nov	Dec
1		1331.50	1420.75	1418.00		1533.75	1483.00	1623.00	1821.00		1699.00	1752.00
2		1337.00	1435.50			1539.50		1637.75	1875.25		1743.00	1747.00
3		1328.00	1421.50		1540.25	1540.00		1669.25		1655.50	1758.00	
4	1388.50	1355.00	1427.00	1435.50	1541.00		1495.00	1679.50		1638.00	1749.00	
5	1368.00			1433.50	1511.00		1510.00	1658.75	1895.00	1617.00		1744.00
6	1368.50			1461.50	1486.50	1549.00	1527.25		1895.00	1635.00		1708.00
7	1367.00	1347.50	1437.50	1459.50		1545.00	1527.50		1810.00	1652.00	1782.00	1735.50
8		1363.50	1426.25	1469.50		1537.75	1541.50	1693.00	1855.00		1795.00	1715.00
9		1365.00	1431.00		1502.00	1537.75		1736.00	1851.50		1784.00	1709.00
10	1368.25	1353.25	1413.25		1513.50	1529.25		1772.00		1661.00	1756.00	
11	1374.00	1364.00	1411.50	1468.00	1508.00		1555.50	1760.00		1663.00	1773.00	
12	1378.75			1450.50	1489.50		1550.50	1736.00	1834.00	1682.00		1659.50
13	1381.50			1457.50	1505.75	1526.25	1579.00		1820.00	1656.00		1672.50
14	1367.00	1365.00	1422.25	1465.75		1516.00	1590.50		1818.50	1678.00	1776.00	1603.00
15		1372.75	1400.50	1476.75		1529.75	1587.00	1739.00	1782.00		1785.00	1574.00
16		1371.25	1402.00		1500.75	1523.25		1782.50	1794.00		1756.00	1594.00
17	1360.50	1379.00	1403.75		1478.50	1537.50		1790.00		1682.00	1742.50	
18	1369.50	1383.50	1420.00	1493.00	1496.50		1599.00	1824.00		1631.00	1719.00	
19	1372.00			1490.50	1493.00		1601.00	1848.00	1794.00	1652.50		1598.00
20	1345.50			1501.00	1490.75	1544.00	1586.00		1799.00	1620.00		1613.50
21	1343.50	1403.00	1432.00	1504.00		1544.75	1601.00		1793.00	1642.50	1702.00	1608.00
22		1401.00	1426.00			1552.50	1602.00	1877.50	1722.00		1699.00	1606.50
23		1409.25	1439.50		1510.50	1523.00		1876.00	1689.00		1681.00	
24	1343.00	1411.50	1447.00		1527.00	1514.75		1770.00		1652.00	1692.50	
25	1324.00	1402.50	1436.00		1526.25		1613.50	1729.00		1656.00	1688.50	
26	1328.00			1497.50	1518.50		1612.75	1788.00	1598.00	1715.00		
27	1334.50			1511.00	1533.00	1498.00	1625.00		1659.00	1718.00		
28	1319.00	1411.00	1417.00	1535.50		1499.00	1613.50		1643.00	1741.00	1714.00	1571.00
29			1417.50			1504.25	1628.50		1613.00		1717.00	1531.00
30			1425.50			1505.50		1825.00	1620.00		1746.00	
31	1327.00		1439.00		1536.50			1813.50		1722.00		
Avg	1356.40	1372.72	1424.01	1473.81	1510.44	1528.66	1572.81	1755.81	1771.88	1665.21	1738.98	1652.31
High	1388.50	1411.50	1447.00	1535.50	1541.00	1552.50	1628.50	1877.50	1895.00	1741.00	1795.00	1752.00
Low	1319.00	1328.00	1400.50	1418.00	1478.50	1498.00	1483.00	1623.00	1598.00	1617.00	1681.00	1531.00
Cumulative Avg			1571.52									

Figure 19-2: Graph and data of last three year gold price (2011)

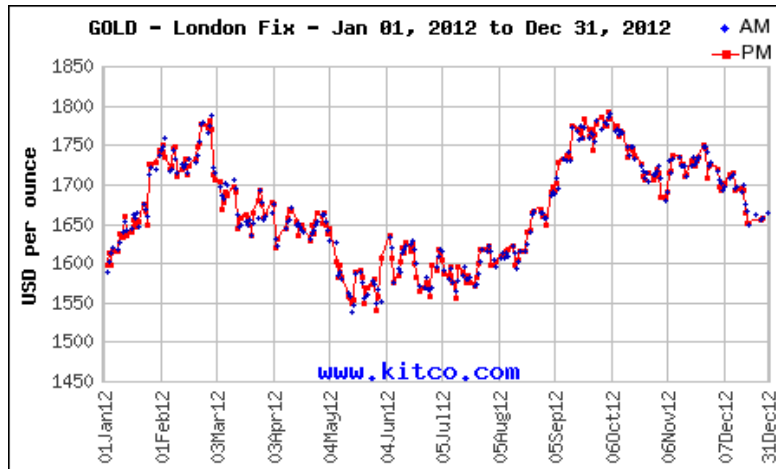

GOLD 2012 London PM Fix -USD www.kitco.com

	Jan	Feb	Mar	Apr	May	Jun	Jul	Aug	Sep	Oct	Nov	Dec
1		1740.00	1714.00		1664.00	1606.00		1599.00		1787.00	1716.25	
2		1751.00	1707.00	1677.50	1648.00		1592.00	1597.00		1775.50	1685.00	
3	1598.00	1734.00		1676.25	1637.75		1617.50	1602.00	1691.50	1775.25		1720.00
4	1613.00			1621.00	1643.75		1613.50		1697.00	1791.75		1697.75
5	1599.00		1705.00	1631.00			1604.00		1690.00	1784.00	1683.50	1694.00
6	1616.50	1719.00	1669.00			1635.00	1587.00	1610.00	1701.00		1691.00	1694.25
7		1724.00	1677.50			1606.00		1611.00	1728.00		1715.25	1701.50
8		1746.00	1690.00		1602.50	1576.50		1613.25		1773.50	1717.00	
9	1615.00	1748.00	1687.50		1582.50		1585.00	1615.00		1774.00	1738.25	
10	1637.00	1711.50		1644.00	1598.50		1595.25	1618.50	1732.00	1761.25		1712.50
11	1634.50			1658.00	1583.00	1584.00	1577.00		1736.75	1769.00		1710.00
12	1661.00		1697.50	1668.50		1603.50	1556.25		1737.00	1766.75	1735.25	1716.25
13	1635.50	1720.00	1690.00	1666.50		1619.50	1595.50	1622.50	1733.25		1726.25	1692.75
14		1722.00	1644.25		1558.50	1613.50		1597.75	1775.50		1725.75	1696.25
15		1733.00	1648.00		1556.50	1627.25		1601.75		1736.00	1710.00	
16	1641.00	1713.00	1658.00	1653.00	1548.50		1589.75	1604.50		1746.50	1713.50	
17	1656.00	1723.00		1635.50	1554.00		1585.25	1614.75	1770.00	1749.00		1695.75
18	1647.00			1644.00	1589.50	1615.50	1575.25		1769.50	1743.00		1694.00
19	1655.00		1661.50	1650.00		1625.50	1584.00		1766.75	1737.00	1730.50	1665.00
20	1653.00	1733.00	1656.75	1641.50		1601.00	1576.25	1615.00	1758.50		1732.25	1650.50
21		1748.00	1649.25		1592.50	1582.00		1639.50	1784.50		1724.00	1651.50
22		1752.00	1635.50		1582.50	1565.50		1642.00		1726.75	1731.00	
23	1675.50	1777.00	1664.00	1629.00	1549.00		1572.25	1665.25		1711.00	1734.50	
24	1665.50	1777.50		1649.50	1568.50		1583.25	1667.00	1762.50	1706.50		
25	1650.00			1637.75	1569.50	1570.00	1601.00		1771.50	1715.50		
26	1727.00		1680.25	1653.50		1576.00	1618.00		1744.75	1716.00	1750.50	
27	1726.00	1772.00	1692.00	1663.50		1573.50	1618.25		1763.00		1746.25	1655.50
28		1781.00	1676.00		1574.60	1558.50		1668.00	1776.00		1708.00	1657.50
29		1770.00	1657.50		1579.50	1598.50		1660.00		1707.00	1725.00	
30	1729.00		1662.50	1651.25	1540.00		1617.75	1660.50		1710.00	1726.00	
31	1744.00				1558.00		1622.00	1648.50		1719.00		
Avg	1656.12	1742.62	1673.77	1650.07	1585.50	1596.70	1593.91	1626.03	1744.45	1747.01	1721.14	1688.53
High	1744.00	1781.00	1714.00	1677.50	1664.00	1635.00	1622.00	1668.00	1784.50	1791.75	1750.50	1720.00
Low	1598.00	1711.50	1635.50	1621.00	1540.00	1558.50	1556.25	1597.00	1690.00	1706.50	1683.50	1650.50
Cumulative Avg			1668.98									

Figure 19-3: Graph and data of last three year gold price (2012)



GOLD 2013 London PM Fix -USD												www.kitco.com
	Jan	Feb	Mar	Apr	May	Jun	Jul	Aug	Sep	Oct	Nov	Dec
1		1669.00	1582.25		1454.75		1242.75	1315.00		1290.75	1306.75	
2	1693.75			1583.50	1469.25		1252.50	1309.25	1392.25	1306.25		1229.50
3	1679.50			1574.75	1469.25	1402.50	1250.00		1399.50	1316.00		1217.25
4	1648.00	1666.00	1574.25	1546.50		1399.50	1251.75		1390.00	1309.75	1320.50	1227.50
5		1673.50	1579.75	1568.00		1404.00	1212.75	1304.75	1385.00		1307.25	1222.50
6		1674.25	1574.00			1400.00		1280.50	1387.00		1319.00	1233.00
7	1645.25	1668.00	1579.50		1444.25	1386.00		1282.50		1323.50	1307.25	
8	1656.00	1668.25	1581.75	1575.00	1468.00		1235.25	1298.25		1329.50	1285.50	
9	1657.75			1577.25	1465.50		1255.50	1309.00	1390.00	1304.00		1237.00
10	1675.00			1575.00	1426.50	1383.25	1256.00		1358.25	1298.50		1266.25
11	1657.50	1652.00	1579.00	1565.00		1374.25	1285.00		1363.75	1265.50	1282.50	1260.75
12		1647.50	1594.00	1535.50		1382.75	1279.75	1341.00	1328.00		1281.25	1225.25
13		1645.00	1589.25		1430.75	1385.00		1328.50	1318.50		1272.50	1232.00
14	1666.50	1646.00	1586.00		1433.75	1391.25		1326.50		1285.50	1286.00	
15	1680.50	1612.25	1595.50	1395.00	1410.00		1284.75	1329.75		1270.50	1287.25	
16	1676.25			1380.00	1381.00		1291.50	1369.25	1324.00	1273.50		1234.75
17	1675.00			1392.00	1368.75	1384.75	1297.25		1312.25	1319.25		1231.75
18	1688.50	1610.75	1603.75	1393.75		1366.75	1283.25		1301.00	1316.50	1283.50	1230.50
19		1607.75	1610.75	1405.50		1372.75	1295.75	1365.00	1365.50		1275.75	1196.00
20		1588.50	1607.50		1354.75	1292.50		1372.50	1349.25		1257.00	1195.25
21	1687.50	1577.00	1613.75		1360.75	1295.25		1363.00		1317.50	1240.00	
22	1690.50	1576.50	1607.75	1424.50	1408.50		1327.00	1375.50		1333.00	1246.25	
23	1690.25			1408.00	1380.50		1333.50	1377.50	1323.00	1331.25		1199.00
24	1671.00			1428.50	1390.25	1286.75	1335.00		1314.25	1344.75		
25	1660.00	1586.25	1599.25	1451.00		1279.00	1326.00		1322.75	1347.75	1243.00	
26		1590.50	1598.00	1471.50		1236.25	1331.00		1333.00		1247.50	
27		1604.25	1603.00			1232.75		1419.25	1341.00		1245.00	1214.50
28	1656.50	1588.50	1598.25		1376.50	1192.00		1419.50		1361.00	1245.50	
29	1663.50			1467.50	1382.50		1329.75	1407.75		1349.25	1253.00	
30	1677.50			1469.00	1413.50		1324.15	1394.75	1326.50	1354.75		1204.50
31	1664.75				1394.50		1314.50			1324.00		
Avg	1670.95	1627.59	1592.86	1485.08	1413.50	1342.36	1286.72	1347.10	1348.80	1316.18	1275.82	1225.40
High	1693.75	1674.25	1613.75	1583.50	1469.25	1404.00	1335.00	1419.50	1399.50	1361.00	1320.50	1266.25
Low	1645.25	1576.50	1574.00	1380.00	1354.75	1192.00	1212.75	1280.50	1301.00	1265.50	1240.00	1195.25
Cumulative Avg			1411.23									

Figure 19-4: Graph and data of last three year gold price (2013)

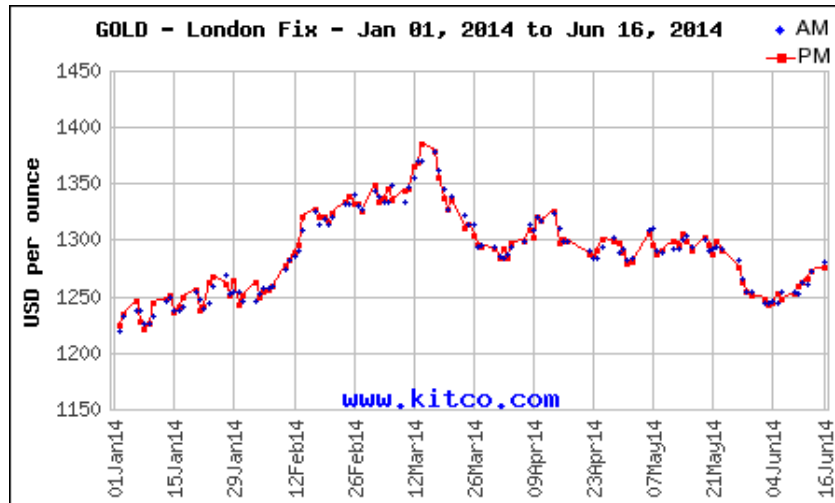

GOLD 2014 London PM Fix -USD												
	Jan	Feb	Mar	Apr	May	Jun	Jul	Aug	Sep	Oct	Nov	Dec
1				1283.75	1278.50							
2	1225.00			1292.00	1281.25	1247.25						
3	1234.50	1262.00	1349.50	1284.00		1242.75						
4		1250.25	1334.75	1297.25		1245.25						
5		1254.50	1337.00			1252.50						
6	1246.25	1256.50	1345.25		1306.25	1247.50						
7	1227.50	1259.25	1335.25	1299.00	1296.00							
8	1221.00			1309.50	1287.00							
9	1226.00			1301.75	1291.25	1253.50						
10	1244.25	1277.00	1344.00	1320.50		1259.50						
11		1282.00	1346.25	1318.00		1262.00						
12		1289.50	1366.00		1298.75	1265.75						
13	1248.00	1296.00	1368.75		1296.50	1273.00						
14	1251.50	1320.00	1385.00	1325.75	1305.25							
15	1236.00			1298.00	1299.00							
16	1241.50			1301.50	1291.50	1276.25						
17	1250.00	1327.50	1378.50	1299.00		1267.50						
18		1320.75	1355.75									
19		1320.50	1338.00		1302.00							
20	1255.75	1316.25	1327.00		1295.50							
21	1238.00	1323.25	1336.00		1287.25							
22	1241.00			1286.75	1298.50							
23	1263.00			1285.25	1291.50							
24	1267.00	1334.75	1310.75	1291.50								
25		1339.00	1313.50	1301.25								
26		1331.75	1304.00									
27	1260.50	1332.25	1296.00		1275.50							
28	1251.25	1326.50	1294.75	1299.00	1263.50							
29	1264.00			1297.75	1255.00							
30	1242.50			1288.50	1250.50							
31	1251.00		1291.75									
Avg	1244.80	1300.97	1336.08	1299.00	1287.53	1257.73						
High	1267.00	1339.00	1385.00	1325.75	1306.25	1276.25						
Low	1221.00	1250.25	1291.75	1283.75	1250.50	1242.75						
Cumulative Avg			1289.44									

Figure 19-5: Graph and data of last three year gold price (2014)

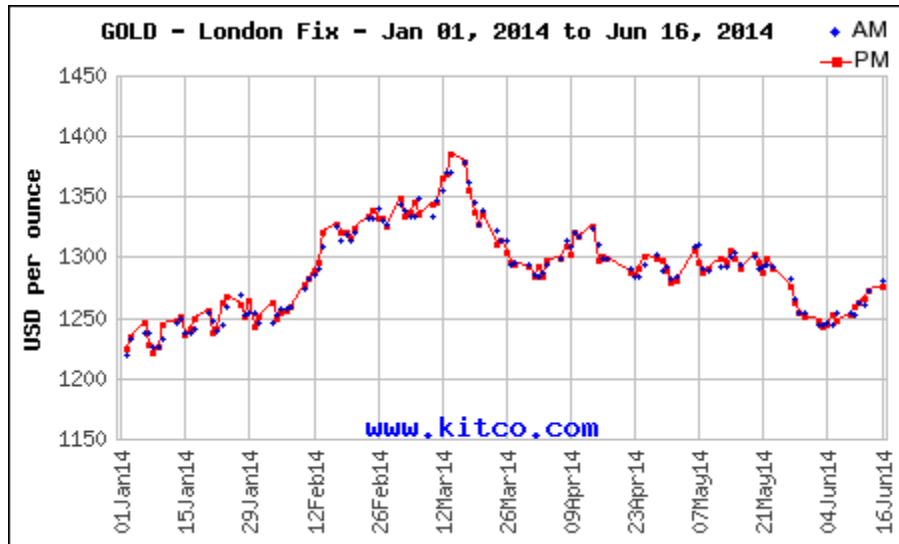

Figure 19-6: Graph of the 2014 US\$ Gold price

20 Environmental Studies, Permitting and Social or Community Impact

20.1 JURISDICTIONS AND APPLICABLE LAWS AND REGULATIONS

The legal framework for the construction and operation of the projected facilities is a combination of provincial, national, and municipal policies, regulations and guidelines. The design and the environmental management of the project facilities and activities must be done in accordance with this legal framework.

20.1.1 PROVINCIAL FRAMEWORK

20.1.1.1 Recent Modifications to the Mining Act

The Quebec Mining Act has been substantially amended and modernized by Bill 70, which the Quebec National Assembly adopted on December 9, 2013. This fourth attempt to update Quebec's mining legislation follows on the heels of the defeat of Bill 43 and that of Bills 79 and 14 in previous legislative sessions. Within the specific context of the Granada Gold Project, the following amendments are relevant:

- Provisions specific to aboriginal communities and referring to an aboriginal community consultation policy specific to the mining sector (obligation to consult aboriginal communities and requires the Minister to consult aboriginal communities separately if the circumstances so warrant).
- On each anniversary date of a mining lease or mining concession, the lessee or grantee will have to send the Minister a report showing the quantity of ore extracted during the previous year, its value, the duties paid under the Mining Tax Act during that period and the overall contributions paid.
- Mining leases to be issued will require the prior approval of a rehabilitation and restoration plan and the issue of a certificate of authorization under the Environment Quality Act, unless the time needed to obtain a certificate is unreasonable.

On July 23, 2013, the Government of Quebec first passes amendments to the Regulation respecting mineral substances other than petroleum, natural gas and brine in order to set new rules concerning the financial guarantees required for the restoration of mining sites. Among other things, those result in an increase of the financial guarantee from 70% to 100% of the projected costs for the work required under the rehabilitation and restoration plan. The guarantee must cover not only restoration costs associated with the accumulation areas, but all costs for the entire mine site and associated infrastructures. It must be paid in three annual instalments. The first instalment corresponds to 50% of the total amount of the guarantee and must be paid within 90 days following the receipt of the approval of the plan. The second and third instalments each represent 25% of the guarantee and must be paid in full by the first and second anniversary date.

Lastly, Bill 70 amends the Regulation respecting environmental impact assessment and review in order to require an environmental impact assessment for all metalliferous ore processing plant construction projects, all metalliferous mine opening and operation projects where the processing or production capacity of the plant or the mine is 2,000 metric tons or more per day.

20.1.1.2 Québec Procedure relating to the Environmental Assessment of the Project

Section 31.1 of the Environment Quality Act (EQA) states that “No person may undertake any construction, work, activity or operation, or carry out work according to a plan or program, in the cases provided for by regulation of the Government without following the environmental impact assessment and review procedure and obtaining an authorization certificate from the Government.”

Moreover, section 2 of the Regulation respecting Environmental Impact Assessment and Review provides the list of projects subject to the environmental impact assessment and review procedure, namely:

“(n.8) the construction of an ore processing plant for metalliferous ore or asbestos ore, where the processing capacity of the plant is 2,000 metric tons or more per day, except in the case of rare earth deposits;

(p) the opening and operation of a metals mine or an asbestos mine that has a production capacity of 2,000 metric tons or more per day, except in the case of rare earth deposits;

Thus, since the Granada Gold Project will have a processing capacity of 550 metric tons per day, it is not subject to the provincial environmental impact assessment and review procedure.

20.1.1.3 Certificates of Authorization (CA)

General Mining Certificate

In order to carry out the Granada Gold Project, one or more certificates of authorization (CAs) will be required from the MDDELCC under Section 22 of the EQA. A form to which are attached the documents and information set out in sections 7 and 8 of the Regulation respecting the Application of the Environment Quality Act is included with a C of A application. For mining activities, C of A applications must also comply with the Directive 019 requirements.

Authorization for Water Supply Intakes and Devices for the Treatment of Potable Water and Disposal of Wastewater

An authorization under Section 32 of the EQA is needed for the treatment of potable water (including for toilets and showers) and the treatment of wastewaters. Forms must be completed and signed by the project engineer, and the required documents must be attached to them. The required documents are administrative documents and a technical document to be signed by the project engineer. The application for an authorization must be submitted to the MDDELCC regional branch.

20.1.1.4 Approval

Approval for the Location of the Waste Dumps

Under Section 241 of the Mining Act, “Every person responsible for the management of a concentration plant, refinery or smelter shall, before commencing activities, have the site intended as a storage yard for tailings approved by the Minister. The same applies to every holder of a mining right, owner of mineral substances or operator who intends to establish a mine tailings site”.

It should be noted that by definition “tailings” means rejected mineral substances, sludge and water, except the final effluent, from extraction operations and ore treatment, and slag from pyrometallurgy operations. Therefore, the location of the waste dumps on a mining right must be approved.

20.1.1.5 Permits

Forest Management Permit for Mining Activities

Under Section 73 of the Sustainable Forest Development Act holders of mining rights can obtain forest management permits relating to mining activities in order to exercise their rights under the Mining Act. This permit holder is allowed to cut timber on the land covered by its mining rights for the construction of buildings or any other operations necessary for its mining activities, in compliance with the Sustainable Forest Development Act and its regulations. The applicant must have already obtained the right to operate the site for mining purposes, a right which is granted by the Mines Division of the MRN. Prior to proceeding with its timber cutting operations, the holders of mining rights must submit a written request to the MRN forest management unit in order to obtain a permit for its mining operations. The request can be

for the clearing of a site for mining activities, the exploratory boring of a gravel bed or the clearing of a gravel or sand pit.

Due to the design of the Granada project, no commercial forest will be removed.

High-Risk Petroleum Equipment Operating Permit

Under Section 120 of the Safety Code, “The owner of a petroleum equipment installation that includes at least one component that is high-risk petroleum equipment must obtain a permit for the use of all the high-risk petroleum equipment situated at the same address, until the equipment is removed from its respective place of use”.

A “high-risk” petroleum equipment as defined in Section 8.01 of the Construction Code is having one of the following characteristics:

- For aboveground storage systems:
 - Capacity of 2 500 or more litres, used to store gasoline;
 - Capacity of 10 000 or more litres, used to store diesel;
 - Capacity of 10 000 or more litres, used to store heating oil and heavy fuel oil except for equipment used for heating a residential single-family dwelling;
- Storage tanks used to store gasoline, diesel, heating oil and heavy fuel oil for profit, regardless of their capacity.

The “Application for a Permit for the Use of a High-Risk Petroleum Equipment” form must be completed and submitted to the Régie du bâtiment. This application must include all of the information and documents identified in Section 121 of the Safety Code. A permit is valid for 24 months. The issuing and renewal of a high-risk petroleum equipment permit are subject to compliance and performance monitoring under the provisions of the Construction Code and the Safety Code.

Explosives Permit

Under the Act respecting Explosives, no person shall possess, store, sell or transport any explosives unless he is holding a permit for such purpose. There will be no explosive storage in the Granada project.

20.1.1.6 Leases

Mining Lease

Under Section 100 of the Mining Act, “no person may mine mineral substances, except surface mineral substances, petroleum, natural gas and brine, unless he has previously obtained a mining lease from the Minister or a mining concession under any former Act relating to mines.”

GBB already have the mining leases for the Granada project except for the small open-pit located west of the actual leases.

Non-Exclusive Lease for the Mining of Surface Mineral Substances

The mining of sand and gravel located outside of mining leases requires a non-exclusive lease for the mining of surface mineral substances, under Section 140 of the Mining Act. The applicant must make a request for a non-exclusive lease by completing the “Application for Non-Exclusive Lease (BNE) for Mining Surface Mineral Substances” form and providing the documents identified in Section 3 of the form.

Lease for the Occupation of the Domain of the State

Under Section 239 of the Mining Act, “the holder of mining rights or the owner of mineral substances may, in accordance with the Act respecting the lands in the domain of the State (Chapter T-8.1), obtain that public lands be transferred or leased to him to establish a storage site for tailings, or a site for mills, shops or facilities necessary for mining activities”. Several components of the Granada Project (waste dumps,

overburden dump, polishing pond) might be located outside of the lands covered by the mining lease. Since a portion of the project is located on public lands, the land in question will need to be leased under Section 47 of the Act respecting the Lands in the Domain of the State.

20.1.1.7 Rehabilitation and Mine Closure Plan

Section 232.1 of the Mining Act states that:

The following persons must submit a rehabilitation and restoration plan to the Minister for approval and carry out the work provided for in the plan:

- (1) every holder of mining rights who engages in exploration work determined by regulation or agrees that such work be carried out on the land subject to his mining rights;
- (2) every operator who engages in mining operations determined by regulation in respect of mineral substances listed in the regulations;
- (3) every person who operates a concentration plant in respect of such substances;
- (4) every person who engages in mining operations determined by regulation in respect of tailings.

The obligation shall subsist until the work is completed or until a certificate is issued by the Minister under section 232.10.

As stated in Section 101, “the [mining] lease cannot be granted before the rehabilitation and restoration plan is approved in accordance with this Act, and the certificate of authorization mentioned in section 22, 31.5, 164 or 201 of the Environment Quality Act (chapter Q-2) has been issued.”

Hence, a rehabilitation plan will have to be prepared as part of the project and approved by the MRN. The rehabilitation and restoration plan should be elaborated in accordance with the provincial Guidelines for Preparing a Mining Site Rehabilitation Plan and General Mining Site Rehabilitation Requirements (1997) which provides to the proponents the rehabilitation requirements. This study accounts for costs of all works needed for the rehabilitation of a mining site following the Regulation respecting Mineral Substances other than Petroleum, Natural Gas and Brine.

20.1.2 FEDERAL FRAMEWORK

20.1.2.1 Canadian Environmental Assessment Act

The Canadian Environmental Assessment Act (CEAA 2012) was introduced on July 6th, 2012. Consequently, projects are now examined according to the requirements of this new law. Thus, under the CEAA 2012, an environmental assessment focuses on potential adverse environmental effects that are within federal jurisdiction, including:

- Fish and fish habitat;
- Other aquatic species;
- Migratory birds;
- Federal lands;
- Impacts that will or could potentially cross provincial or international boundaries;
- Impacts on Aboriginal peoples, such as land use and traditional resources;
- Impacts that are directly linked or necessarily incidental to any federal decisions about a project.

An environmental assessment will consider a comprehensive set of factors that include any cumulative effect, mitigation measure and comment received from the public.

Regulations Designating Physical Activities determines the specific activities which constitutes designated projects that may require an environmental assessment by the Canadian Environmental Assessment

Agency (hereinafter the CEA Agency) or by the Canadian Nuclear Safety Commission or the National Energy Board. It should be noted that this Regulation was officially amended on October 24, 2013 (Regulation amending the Regulations Designating Physical Activities). The schedule specifies the designated projects that may require an environmental assessment under the responsibility of the CEA Agency (Sections 1 to 30), the Canadian Nuclear Safety Commission (Sections 31 to 38) or the National Energy Board (Sections 39 to 45). With regards to the Granada Project, it has been determined that the following designated activities are to be considered:

“16. The construction, operation, decommissioning and abandonment of a new [...] (c) rare earth element mine or gold mine, other than a placer mine, with an ore production capacity of 600 t/day or more.”

However, considering the above information, recent experience with the CEAA 2012 and the proposed process capacity (550 metric tons per day), the Granada Project is not a designated project and it will not consequently have to go through the Canadian environmental assessment process.

20.1.2.2 Authorization to Alter Fish Habitat

Section 35 of the Fisheries Act specifies that:

- (1) No person shall carry on any work, undertaking or activity that results in the harmful alteration or disruption, or the destruction, of fish habitat.
- (2) A person may carry on a work, undertaking or activity without contravening subsection (1) if:
 - (a) the work, undertaking or activity is a prescribed work, undertaking or activity, or is carried on in or around prescribed Canadian fisheries waters, and the work, undertaking or activity is carried on in accordance with the prescribed conditions;
 - (b) the carrying on of the work, undertaking or activity is authorized by the Minister and the work, undertaking or activity is carried on in accordance with the conditions established by the Minister;
 - (c) the carrying on of the work, undertaking or activity is authorized by a prescribed person or entity and the work, undertaking or activity is carried on in accordance with the prescribed conditions;
 - (d) the harmful alteration or disruption, or the destruction, of fish habitat is produced as a result of doing anything that is authorized, otherwise permitted or required under this Act; or
 - (e) the work, undertaking or activity is carried on in accordance with the regulations.

When a project includes a known risk of affecting fish and fish habitat, such a project must be submitted to Fisheries and Oceans Canada (DFO) for its review.

However, Granada project design was done in a way that no fish habitats will be directly impacted by the implementation of any accumulation areas.

Licence for Explosives Factories and Magazines

Under Section 7(1) a) of the Explosives Act, a licence issued by the Minister of Natural Resources Canada is required for the operation of explosives plants and magazines in Canada.

However, there will be no explosives plant on site.

20.2 ORE AND WASTE ROCK ENVIRONMENTAL CHARACTERIZATION

20.2.1 METHODOLOGY

- Three (3) ore samples and eight (8) waste rock samples were selected by Gold Bullion Corp's geologists for geochemical characterization. The following geochemical tests have been performed on all samples for the environmental characterization of the mining material:
- Metal contents were determined by partial digestion using aqua regia followed by measurements of metals, according to Method MA. 200 – Mét. 1.2 and Method MA. 200 Hg 1.1 for mercury;
- US EPA Synthetic Precipitation Leaching Procedure (SPLP 1312) leaching tests were performed to simulate the effects of acid rain, according to Method MA.100-Lix.com.1.0 and measurement of metals in leachates according to CEAEQ Method MA. 200 – Mét. 1.2 and Method MA. 200 Hg 1.1 for mercury;
- Neutralization Potential (NP) according to Modified Sobek ABA Method and Acidification Potential (AP) by ASTM Method D-2492-02.

SPLP test was favored to the US EPA Toxicity Characteristic Leaching Procedure (TCLP 1311) leaching test since it is known to be more representative of future climatic conditions expected over mining residues. Furthermore, TCLP test is known to underestimate the arsenic leaching potential, which is an important issue to consider in the project since the ore contains arsenopyrite.

20.2.2 RESULTS

20.2.2.1 Ore

Metal Content (environmentally available): The most important metals encountered in the three ore samples tested were: iron, calcium, aluminum, magnesium and manganese (Table 20-1). Other metals were measured at median concentrations lower than 100 mg/kg.

Concentrations exceeding the A criteria of the Quebec's Soil Protection and Rehabilitation of Contaminated Sites Policy (SPRCSP) were measured in at least one sample for arsenic (3), copper (1), nickel (1), silver (1) and selenium (1). For most of the parameters, with the exception of arsenic, median and average values are below the A criteria. Average arsenic content is 1 400 mg/kg, which exceeds significantly the A criteria (5 mg/kg).

Acid Generating Potential: Sulfides content in the three samples varied from 0.12 to 2.17% with an average of 1.03%, which is above the 0.3% criteria of Directive 019 (Table 20-2). Individually, two samples present NP/AP ratio (3.1 and 3.2) slightly above Directive 019 criteria (3.0). However, average neutralizing potential (NP) is 58.5 mgCaCO₃/t, whereas mean acid generation potential (AP) is 32.1 mgCaCO₃/t. Therefore the NP/AP ratio of all samples was 1.82, which is below the Directive 019 criteria.

Furthermore, cyanide testing was performed in 2013 at URSTM laboratory on a ore composite sample. Sulfides content was 1.23 % with an AP of 38.4 mgCaCO₃/t and a NP of 65.2 mgCaCO₃/t (NP/AP ratio = 1.7). These results were similar to the results of individual samples.

Leaching Potential: Most of the metals analyzed indicated concentrations below SPRCSP criteria for the protection of groundwaters (Table 20-3). Only one sample displayed an aluminum concentration (1.1 mg/l) exceeding the associated criteria (0.75 mg/l). However, the average aluminum concentration (0.66 mg/l) of the three samples is below the criteria. Although arsenic content is typically high in the ore, the low concentrations measured during testing (0.043 mg/l, 0.11 mg/l and 0.13 mg/l) suggested that this element should not leach into groundwaters and surface waters.

Table 20-1: Environmentally Available Contents (partial digestion) – Ore

Parameter	Unit	Soil Protection and Contaminated Sites Rehabilitation Policy			Ore - Total content			Average ²
		Criterion A ¹	Criterion B	Criterion C	GR-11-214	GR-11-388	GR-11-353	
Phosphore								
Total phosphorus	mg/kg	-	-	-	710	23	1,300	678
Metals and metalloids								
Aluminium (Al)	mg/kg	-	-	-	6,600	390	570	2,520
Antimony (Sb)	mg/kg	-	-	-	<2	<2	<2	<2
Silver (Ag)	mg/kg	0.5	20	40	<0.5	<0.5	3.2	1.2
Arsenic (As)	mg/kg	5	30	50	1,200	1,300	1,700	1,400
Baryum (Ba)	mg/kg	200	500	2000	35	<5	7	15
Beryllium (Be)	mg/kg	-	-	-	<0.5	<0.5	<0.5	<0.5
Bismuth (Bi)	mg/kg	-	-	-	<7	<7	<7	<7
Boron (B)	mg/kg	-	-	-	<5	<5	<5	<5
Cadmium (Cd)	mg/kg	1.5	5	20	<0.5	<0.5	<0.5	<0.5
Calcium (Ca)	mg/kg	-	-	-	19,000	3,600	23,000	15,200
Chromium (Cr)	mg/kg	85	250	800	34	<2	<2	34
Cobalt (Co)	mg/kg	20	50	300	18	3	15	12
Copper (Cu)	mg/kg	50	100	500	58	5	24	29
Tin (Sn)	mg/kg	5	50	300	<4	<4	<4	<4
Iron (Fe)	mg/kg	-	-	-	34,000	4,100	34,000	24,033
Lithium (Li)	mg/kg	-	-	-	<10	<10	<10	<10
Magnesium (Mg)	mg/kg	-	-	-	12,000	810	7,800	6,870
Manganese (Mn)	mg/kg	1000	1000	2200	710	97	680	496
Molybdenum (Mo)	mg/kg	6	10	40	1	<1	3	1.5
Nickel (Ni)	mg/kg	50	100	500	69	5	13	29
Lead (Pb)	mg/kg	50	500	1000	<5	<5	9	3.2
Potassium (K)	mg/kg	-	-	-	3,800	<40	270	1,363
Selenium (Se)	mg/kg	0.5	3	10	<1	<1	1	0.7
Silicon (Si)	mg/kg	-	-	-	500	120	300	307
Sodium (Na)	mg/kg	-	-	-	<40	<40	<40	<40
Strontium (Sr)	mg/kg	-	-	-	390	25	460	292
Tellurium (Te)	mg/kg	-	-	-	<20	<20	<20	<20
Thallium (Tl)	mg/kg	-	-	-	<2	<2	<2	<2
Titanium (Ti)	mg/kg	-	-	-	480	<5	10	164
Vanadium (V)	mg/kg	-	-	-	15	<5	<5	6.7
Zinc (Zn)	mg/kg	120	500	1500	44	<10	12	20

Result Result greater than criterion A

Result Result greater than criterion B

Result Result greater than criterion C

¹ Background levels for inorganic substances (criterion A) for the Supérieur Geological Province according to the Soil Protection and Contaminated Sites Rehabilitation Policy.

² To calculate the average values, results lower than analytical detection limit were regarded as being equal to half thereof. Thus, this average should be considered with caution.

Table 20-2: Acid Mine Drainage Potential - Ore

Parameter	Unit	Directive 019 Criteria	Samples			Average
			GR-11-214	GR-11-388	GR-11-353	
Sulfur content	%	>0,3	1.67	0.23	3.21	1.70
Sulfate content	%	–	0.87	0.11	1.04	0.67
Sulfides content	%	–	0.79	0.12	2.17	1.03
Potential to generate acid (PA)	kg CaCO ₃ /t	–	24.7	3.8	67.8	32.10
Potential neutralizing (PN)	kg CaCO ₃ /t	–	77.8	12.3	85.3	58.47
Potential net (PN-PA)	kg CaCO ₃ /t	<20	53.1	8.5	17.5	26.37
Ratio PN/PA	unit	<3	3.1	3.2	1.3	2.53

Table 20-3: Leaching Potential - SPLP leaching Procedure 1312 - Ore

Parameter	Unit	Detection limit	Seepage into surface water or infiltration into sewers Criteria ¹	Samples			Average ²
				GR-11-214	GR-11-388	GR-11-353	
Total Phosphorus	mg/l	0.1	0.03 ^m	<0.1	<0.1	<0.1	<0.1
Metals and metalloids							
Aluminium (Al)	mg/l	0.03	0.75 ^f	0.72	0.17	1.1	0.66
Antimony (Sb)	mg/l	0.006	1.1	<0.006	<0.006	0.013	0.006
Silver (Ag)	mg/l	0.0003	0.00062 ^g	<0.0003	<0.0003	<0.0003	<0.0003
Arsenic (As)	mg/l	0.002	0.34 ^h	0.13	0.043	0.11	0.094
Baryum (Ba)	mg/l	0.005	0.6 ^g	<0.005	<0.005	0.009	0.005
Beryllium (Be)	mg/l	0.002	0.00373 ^g	<0.002	<0.002	<0.002	<0.002
Bismuth (Bi)	mg/l	0.05	-	<0.05	<0.05	<0.05	<0.05
Boron (B)	mg/l	0.05	28	<0.05	<0.05	<0.05	<0.05
Cadmium (Cd)	mg/l	0.001	0.0011 ^g	<0.001	<0.001	<0.001	<0.001
Calcium (Ca)	mg/l	0.5	-	6.9	7.9	6.9	7.2
Chromium (Cr)	mg/l	0.007	-	<0.007	<0.007	<0.007	<0.007
Cobalt (Co)	mg/l	0.01	0.37	<0.01	<0.01	<0.01	<0.01
Copper (Cu)	mg/l	0.003	0.0073 ^g	<0.003	<0.003	<0.003	<0.003
Tin (Sn)	mg/l	0.05	-	<0.05	<0.05	<0.05	<0.05
Iron (Fe)	mg/l	0.1	3.4 ⁱ	<0.1	<0.1	0.4	0.2
Lithium (Li)	mg/l	0.1	0.91	<0.1	<0.1	<0.1	<0.1
Magnesium (Mg)	mg/l	0.2	-	2.3	0.3	2.4	1.7
Manganese (Mn)	mg/l	0.003	2.3 ^g	0.004	0.006	0.015	0.008
Molybdenum (Mo)	mg/l	0.01	29	<0.01	<0.01	<0.01	<0.01
Nickel (Ni)	mg/l	0.006	0.26 ^g	<0.006	<0.006	<0.006	<0.006
Lead (Pb)	mg/l	0.001	0.034 ^g	<0.001	<0.001	<0.001	<0.001
Potassium (K)	mg/l	0.2	-	5.4	0.9	5.3	3.9
Selenium (Se)	mg/l	0.001	0.062 ^k	<0.001	<0.001	<0.001	<0.001
Silicon (Si)	mg/l	0.1	-	1.4	2.2	2.0	1.9
Sodium (Na)	mg/l	0.2	-	<0.2	<0.2	<0.2	<0.2
Strontium (Sr)	mg/l	0.05	40	0.08	<0.05	0.08	0.06
Tellurium (Te)	mg/l	0.01	-	<0.01	<0.01	<0.01	<0.01
Thallium (Tl)	mg/l	0.01	0.047	<0.01	<0.01	<0.01	<0.01
Titanium (Ti)	mg/l	0.05	-	<0.05	<0.05	<0.05	<0.05
Vanadium (V)	mg/l	0.01	0.11	<0.01	<0.01	<0.01	<0.01
Zinc (Zn)	mg/l	0.005	0.067 ^g	<0.005	<0.005	<0.005	<0.005

Result Result above the groundwater seepage criterion but the total content of this sample is lower than the criterion A (see Table 1a)

Result Result is greater than the groundwater seepage criterion but there is no criterion A for this parameter

Result Result is greater than the groundwater seepage criterion and the total content of the sample is higher than criterion A

¹ According to the Soil Protection and Contaminated Sites Rehabilitation Policy, criteria grid applicable to cases of groundwater contamination.

² To calculate the average/median values, results lower than analytical detection limit were regarded as being equal to half thereof. Thus, this average should be considered with caution.

20.2.2.2 Waste Rock

Metal Content (environmentally available): The most important metals encountered in the eight waste rock samples tested were: iron, aluminum, manganese and titanium (Table 20-4). Other metals were measured at median concentrations lower than 100 mg/kg.

Concentrations exceeding the A criteria of the Quebec’s Soil Protection and Rehabilitation of Contaminated Sites Policy (SPRCSP) were measured in at least one sample for arsenic (8), cadmium (1), cobalt (2), copper (2), molybdenum (1) and zinc (1). For most of the parameters, with the exception of

arsenic, median and average values are below the A criteria. Average and median arsenic contents were 95 mg/kg and 15 mg/l, respectively, which exceed A criteria (5 mg/kg).

Acid Generating Potential: The average sulfides content in the samples was low (0.40%) (

Table 20-5). The average neutralizing potential (NP) estimated (57.1 mgCaCO₃/t) was significantly higher than the average acidification potential (AP) estimated (12.6 mgCaCO₃/t). The average NP/AP ratio was about 4.55, which is above the ratio recommended in Directive 019 (3.0). Only one of eight samples exhibited an acid generating potential as per Directive 019 criteria. These results validated the MDDELCC decision to authorize the actual operation of a waste rocks quarry on the site for construction materials purpose.

Leaching Potential: Several metals indicated concentrations above SPRCSP criteria for the protection of groundwaters, i.e.: aluminum (7 of 8 samples), silver (1 of 8) and iron (1 of 8) (Table 20-6). For most of the parameters, with the exception of aluminum, median and average values were below the corresponding criteria.

Average and median aluminum content were 1.7 mg/l and 1.2 mg/l, respectively (criteria is 0.75 mg/l). However, it is assumed that aluminum leaching would not be expected in the course of kinetic testing and real storage conditions, since is recognized that static tests overestimate leaching potential.

Furthermore, it is worth reminding that during a TCLP testing performed on 2 waste rock samples for a previous request of authorization for waste rock beneficiation, leachate concentrations in arsenic were 0.030 and 0.049 mg/L.

Table 20-4: Environmentally Available Contents (partial digestion) - Waste Rock

Parameter	Soil Protection and Contaminated Sites Rehabilitation Policy			Waste rock - Total content								Median
	Criterion A ¹	Criterion B	Criterion C	1041383	1099494	1180508	1181860	201879	209130	209132	209553	
Métaux et métalloïdes												
Aluminium (Al)	-	-	-	4,500	7,200	8,900	7,900	4,800	5,600	7,100	8,300	7,150
Silver (Ag)	0.5	20	40	<0,5	<0,5	<0,5	<0,5	<0,5	<0,5	<0,5	<0,5	<0,5
Arsenic (As)	5	30	50	21	33	13	14	650	6	10	16	15
Beryllium (Be)	-	-	-	2.2	0.2	0.2	0.2	0.5	0.1	0.2	0.2	0.2
Cadmium (Cd)	0.9	5	20	0.3	<0,1	<0,1	<0,1	1.1	<0,1	<0,1	<0,1	0.7
Chromium (Cr)	85	250	800	13	48	67	67	13	52	60	69	56
Cobalt (Co)	20	50	300	7	20	18	21	6	11	15	24	17
Coper (Cu)	50	100	500	29	48	20	60	10	33	35	51	34
Iron (Fe)	-	-	-	20,000	29,000	25,000	26,000	16,000	15,000	18,000	25,000	22,500
Manganese (Mn)	1,000	1,000	2,200	980	780	760	340	520	420	230	500	510
Molybdenum (Mo)	6	10	40	6.2	1.6	2.6	2.1	2.9	2.0	1.0	1.8	2.1
Nickel (Ni)	50	100	500	7.1	49	41	40	4.6	27	33	37	35
Lead (Pb)	40	500	1,000	8	5	2	1	12	4	6	5	5
Selenium (Se)	3	3	10	2.1	0.8	1.4	1.1	1.0	1.0	0.6	1.4	1.1
Titanium (Ti)	-	-	-	740	420	78	170	350	410	690	450	415
Zinc (Zn)	120	500	1,500	78	35	29	23	230	20	29	32	31

- Result** Result greater than criterion A
- Result** Result greater than criterion B
- Result** Result greater than criterion C

¹ Background levels for inorganic substances (criterion A) for the Supérieur Geological Province according to the Soil Protection and Contaminated Sites Rehabilitation Policy.

Table 20-5: Acid Mine Drainage Potential - Waste Rock

Paramètre	Unit	Detection limit	Directive 019 Criteria	Sample								Average
				1041383	1099494	1180508	1181860	201879	209130	209132	209553	
Sulfur content	%	0,02	>0,3	0,83	0,60	0,57	1,01	0,46	0,34	0,32	0,64	0,60
Sulfate content	%	0,01		0,24	0,13	0,17	0,27	0,30	0,15	0,13	0,16	0,19
Sulfides content	%	0,02		0,59	0,47	0,40	0,74	0,16	0,19	0,19	0,48	0,40
Potential to generate acid (PA)	kg CaCO ₃ /t	0,3		18,4	14,7	12,5	23,1	5,0	5,9	5,9	15,0	12,6
Potential neutralizing (PN)	kg CaCO ₃ /t	0,1		75,0	80,5	85,5	23,3	60,3	52,0	19,8	60,5	57,1
Potential net (PN-PA)	kg CaCO ₃ /t	0,1	<20	56,6	65,8	73,0	0,2	55,3	46,1	13,9	45,5	44,6
Ratio PN/PA	unité		<3	4,1	5,5	6,8	1,0	12,1	8,8	3,4	4,0	4,55

Table 20-6 : Leaching Potential - SPLP Leaching Procedure 1312 - Waste Rock

Parameter	Unit	Seepage into surface water or infiltration into sewers Criteria ¹	Sample								Median
			1041383	1099494	1180508	1181860	201879	209130	209132	209553	
Basic parameters											
pH of extraction fluid	-	^a	7.9	7.8	3.5	7.7	8.0	7.9	7.9	7.9	7.9
Metals and metalloids											
Aluminium (Al)	mg/l	0.75 ^f	0.67	1.1	2.0	1.4	1.1	4.9	1.2	1.2	1.2
Silver (Ag)	mg/l	0.00062 ^g	0.0005	<0.0003	0.0009	<0.0003	0.0003	0.0006	0.0003	0.0003	0.0003
Arsenic (As)	mg/l	0.34 ^h	0.026	0.013	0.006	0.005	0.210	0.010	0.013	0.006	0.012
Beryllium (Be)	mg/l	0.0037 ^g	<0.002	<0.002	<0.002	<0.002	<0.002	<0.002	<0.002	<0.002	<0.002
Cadmium (Cd)	mg/l	0.0011 ^g	<0.001	<0.001	<0.001	<0.001	<0.001	<0.001	<0.001	<0.001	<0.001
Chromium (Cr)	mg/l	-	<0.007	<0.007	<0.007	<0.007	<0.007	0.026	<0.007	<0.007	<0.007
Cobalt (Co)	mg/l	0.37	<0.01	<0.01	<0.01	<0.01	<0.01	<0.01	<0.01	<0.01	<0.01
Copper (Cu)	mg/l	0.0073 ^g	<0.003	<0.003	<0.003	<0.003	<0.003	<0.003	<0.003	<0.003	<0.003
Iron (Fe)	mg/l	3.4 ⁱ	<0.1	0.2	1.6	0.3	0.1	6.3	0.3	0.1	0.25
Manganese (Mn)	mg/l	2.3 ^g	0.005	0.005	0.043	0.005	0.004	0.13	0.004	<0.003	0.005
Molybdenum (Mo)	mg/l	29	<0.01	<0.01	<0.01	<0.01	<0.01	<0.01	<0.01	<0.01	<0.01
Nickel (Ni)	mg/l	0.26 ^g	<0.006	<0.006	<0.006	<0.006	<0.006	0.012	<0.006	<0.006	<0.006
Lead (Pb)	mg/l	0.034 ^g	<0.001	<0.001	<0.001	<0.001	<0.001	0.004	<0.001	<0.001	<0.001
Selenium (Se)	mg/l	0.062 ^k	<0.001	<0.001	<0.001	<0.001	0.001	0.001	<0.001	<0.001	<0.001
Titanium (Ti)	mg/l	-	<0.05	<0.05	<0.05	<0.05	<0.05	0.24	<0.05	<0.05	<0.05
Zinc (Zn)	mg/l	0.067 ^g	<0.005	<0.005	<0.005	<0.005	<0.005	0.01	<0.005	<0.005	<0.005

Result Result above the groundwater seepage criterion but the total content of this sample is lower than the criterion A (see Table 1a)

Result Result is greater than the groundwater seepage criterion but there is no criterion A for this parameter

Result Result is greater than the groundwater seepage criterion and the total content of the sample is higher than criterion A

¹ According to the Soil Protection and Contaminated Sites Rehabilitation Policy, criteria grid applicable to cases of groundwater contamination. The notes of these criteria are presented in Appendix 3.1.

² To calculate the average/median values, results lower than analytical detection limit were regarded as being equal to half thereof. Thus, this average should be considered with caution.

20.2.2.3 Ore and waste rock management

According to the classification of mining waste of the Directive 019, waste rock is «low risk» and ore is «acid generating».

Therefore, no special measures for the protection of groundwaters and surface waters (except control of suspended solids) are required for percolation waters from the waste dumps.

A geomembrane liner will be installed at the temporary ore stockpile area in order to collect percolation waters and treat them if necessary to respect Directive 019 requirements for effluent before discharge in the environment.

20.3 ENVIRONMENTAL BASELINE STUDIES

The Project area considered as part of this study extends 8 km by 8 km and is centered on the projected mine site.

Description of the bio-physical and socio-economic components of the study area environment was described based on information collected from various sources:

1. Field surveys;
2. Aerial photographs and/or satellite images, maps, and geomatics tools;
3. Information gathered from various governmental agencies;
4. Studies from the scientific and technical literature.

20.3.1 SOCIO-ECONOMIC COMPONENTS

The project is located in the Abitibi-Témiscamingue Administrative Region (08), more specifically in the Granada District of the town of Rouyn-Noranda. The city, which is an important center for the Quebec mining industry, has a population of just over 41,000 people.

In recent years, the economic situation in the region has fluctuated, alternating between slowdowns and recoveries. Since 2010, the region has returned to growth with employment and unemployment rates improving significantly compared to the Province. Historically, and still today, Rouyn-Noranda's economic activity is based on the industrial sector, dominated by the mining industry as well as medium and small businesses servicing the mines.

According to the zoning plan of Rouyn-Noranda, the project is located partly in an "exploitation of resources" (ER-2) area and partly in an "industrial" area (I-2). The "mining" use is compatible with the current zoning, insofar as the city is informed in advance of any mining development project.

There are about twenty houses in a radius of one kilometer from the Granada property. Residents use wells to meet their water needs. On Rang Lavigne, there are about 30 houses within a radius of 2 km around the pits; these residents also use private wells for their drinking water supply. In addition to the residential areas, there are a few public infrastructures such as a church, a cemetery and a primary school northwest of the proposed site. According to Rouyn-Noranda's Master Plan, the Granada district has a good potential for residential, recreational (e.g. bike path) and industrial developments.

The La Bruère River and its surroundings are used both by hunters and anglers. The Centre de plein air de Granada, offering hiking, snowshoeing, cross-country and nordic skiing is located more or less 1 km south of the mine site at the junction of the Granada avenue and Rang Lavigne. Furthermore, during winter, several snowmobile and ATV trails are used in the vicinity of the project site. During the summer months, ATV uses the same route as in winter, but only east of Granada Avenue.

No known sector or archaeological site is located near the proposed mine site.

20.3.2 PHYSICAL COMPONENTS

20.3.2.1 Hydrology and Hydrogeology

Locally, surface waters flow towards Beauchastel and Bruyère Lakes. A small portion of the flow drains to the North towards Pelletier Lake. A few streams of various sizes are flowing in the area, notably the Beauchastel and Pelletier Rivers. The nearest stream to the project site is the Bruère River, which flows towards Bruyère Lake. The project site is located in the headwaters of the Bruère River.

Typically, the geological units encountered in the study area display limited hydraulic properties. Indeed, these rocks have a low «primary» porosity related to the characteristics of their rock matrix, which inhibits their capacity to store large volumes of water and to facilitate groundwater flow. The hydraulic properties of these types of rock are associated with a «secondary» type porosity, generated by fractures and faults in the rock mass. The density and connectivity of the fracture network will control groundwater flow, and allow locally the storage of significant volumes of water. The occurrence of the Cadillac Fault located in the vicinity of the project area may influence locally the fracture network.

20.3.2.2 Groundwater Quality

There were no monitoring wells specifically installed for the project. However, groundwater samples were first collected in four (4) mineral exploration boreholes in June 2013 in order to obtain a preliminary assessment of the groundwater quality.

All groundwater samples showed concentrations below the effluent criteria of the MDDELCC Directive 019, and the aquatic life protecting acute toxicity criteria, with the exception of one sample that displayed a copper content (0.0145 mg/l) slightly above the acute toxicity criteria for the protection of aquatic life (0.0146 mg/l). Concentrations exceeding drinking-water criteria were detected in all samples for manganese; and in one sample for iron and arsenic. However, iron and manganese are only aesthetical parameters.

Two (2) other boreholes were sampled in September 2013 and May 2014. All samples displayed concentrations in dissolved manganese above MDDELCC drinking water criteria. One sample also exhibited arsenic content above the drinking water criteria; and one sample a silver content (0.0019 mg/l) exceeding the acute toxicity criteria (0.00062 mg/l).

Lastly, groundwater from most of the private wells in the project area was sampled in March 2014, and results were sent to owners. Results indicated numerous arsenic concentrations, and a few lead concentrations exceeding the drinking water criteria. Arsenic concentration pattern agrees with the known contaminated area. High lead concentrations measured in some samples are assumed to be associated with house plumbing.

20.3.2.3 Surface Water Quality

Six (6) surface water sampling sites were established along the most important streams in the project area. Samples were collected in accordance with applicable provincial and federal guidelines. Water quality was examined according to Canadian recommendations for water quality/aquatic life protection and surface water quality criteria from the MDDELCC.

Surface waters are relatively turbid, mildly acidic and have high buffering capacities. Hardness is highly variable: from very soft waters to hard waters. Surface waters are characteristics of shallow aquatic environments rich in organic matter.

Concentrations of metals measured in the surface water samples were variable. Aluminium, arsenic, copper, cadmium, chromium, iron, manganese and zinc were detected in several samples at levels exceeding MDDELCC criteria and CCME recommendation on surface water quality for the protection of aquatic life.

Petroleum hydrocarbon contamination was detected in two samples. The hydrocarbon content of 0.2 and 0.1 mg/l exceeded the chronic toxicity criteria for the protection of aquatic life (0.010 mg/l).

20.3.2.4 Sediment Quality

Sediment samples were collected at the same six (6) sampling sites used for water quality assessment. Results have been compared to freshwater sediment quality criteria from Environment Canada and MDDELCC.

Typically, the sediment samples collected consisted mainly of silt (57.2 to 72.1 %), clay (16.5 to 30.4 %) and sand (6.7 to 12.4 %). The most abundant metals in the sediments were iron and magnesium. Metal concentrations were above freshwater sediment quality criteria in one or more sampling sites for: chromium (6 samples); arsenic, cadmium, copper, lead and zinc (4 samples); nickel and mercury (1 sample). One sample contained 238 mg/kg of petroleum hydrocarbon.

20.3.2.5 Existing Open-Pit Water Quality

Water from the existing open pits was sampled in March 2013. Three (3) samples were collected in each pit. Overall, results were similar for each distinct pit. All results indicated concentrations below the Directive 019 effluent criteria.

Typically, water pH was slightly alkaline (± 7.8), and hardness was high (127 mg CaCO₃/l to 263 mg CaCO₃/l). Average arsenic content was 0.044 mg/l, which is significantly smaller than the aquatic life protection criteria (acute toxicity) (0.34 mg/l), but higher than the drinking water criteria. Finally, biotesting performed in May 2014 on pit water samples indicated no toxicity for the rainbow trout and *Daphnia magna*.

According to the results, only total suspended solids (TSS) must be controlled prior to discharge in surface waters during the dewatering phase.

20.3.3 BIOLOGICAL COMPONENTS

20.3.3.1 Terrestrial Habitats and Wetlands

The Project is located within the balsam fir / white birch stand domain. This bioclimatic domain is located just south of the spruce-moss forest domain and is part of the continuous boreal forest sub-zone. Within the Abitibi-Témiscamingue region, balsam fir / white birch stands covers about half of the area following information provided by the Québec Department of Forest, Wildlife and Parks in its Regional Portrait (MRNF, 2006)³. Such type of stands is of course dominated by balsam firs and white birches, but the presence of white spruces, black spruces, jack pines, trembling aspens and tamaracks can easily be observed. Commonly, balsam fir and white birch stands, in which occur white spruces, are associated with mesic environments while poorly drained sites are dominated by the spruce-moss forest, in which also grow tamaracks, or by wetlands. Well-drained sites host mostly jack pines and balsam fir stands.

Based on local ecoforestry maps produced by the MFFP using aerial photos, the Project area is dominated by mixed forests (about 50%), mostly dominated by deciduous species such as trembling aspens (40%). The second most abundant type of stands is mixed regenerating forest (about 10%). Otherwise, white birch, black spruce and balsam fir stands are observed. Already disturbed areas cover almost 8% of the Project area.

Wetlands do cover about 6 % of the total Project area. Those are alder forests (shrub swamps), peatlands and floodplains (about 2% each). The ecological value of those wetlands was evaluated by Genivar (2012) as part of the Rouyn-Noranda Wetland Management Plan. That analysis was completed in line with the guidelines established by MDDELCC which considers both biotic and abiotic aspects. Most wetlands identified as part of that study within the Project area are of medium ecological value.

20.3.3.2 Terrestrial and Aquatic Wildlife

Mammals

³ MRNF (*Ministère des Ressources naturelles et de la Faune*). 2006. Portrait territorial – Abitibi-Témiscamingue. 88 p. [Online] <http://www.mrn.gouv.qc.ca/abitibi-temiscamingue/region/portrait.jsp>

Relatively speaking, the Abitibi-Témiscamingue region is known for its diversified wildlife with four (4) large mammal, thirty-two (32) small mammal and twenty (20) fur-bearing mammal species present or potentially present at the regional scale. The most abundant among those are the white-tailed deer, moose, black bear, snowshoe hare, American porcupine, American beaver, American red squirrel, Canada lynx, river otter, American marten, fisher, muskrat, and American mink.

Within the vicinity of the Project area, hunting and trapping data for the 2000-2012 period provided by the MFFP have confirmed the presence of black bears and white-tailed deer. According to the OBVT (2011) ⁴, the white-tailed deer is at its northern limit of distribution in the Rouyn-Noranda area. A muskrat habitat, considered as a legally designated wildlife habitat following the Act respecting the conservation and development of wildlife, is located at the limit of the Project area, near Bruyère Lake.

Amphibians and Reptiles

Considering the relatively harsh climate typical of the region, amphibians and reptiles are poorly diversified in the area. According to the OBVT (2011), blue-spotted salamander, green frog and leopard frog are present in the area.

Avifauna

More than 280 bird species are known to be present in the Abitibi-Témiscamingue region, among which 20 are considered as rare (OBVT, 2011). Several of those species are aquatic (ex. waterfowl species such as the common loon). The Témiscamingue watershed, within which Rouyn-Noranda is located, is included in the tundra swan and sandhill crane migratory corridors (OBVT, 2011). Other bird species include forest birds (ex. warblers, sparrows, grouses) and prey birds (ex. bald eagle).

Three waterfowl gathering areas, considered as a legally designated wildlife habitat following the Act respecting the conservation and development of wildlife, are located at the borders of the Project area: one at Pelletier Lake; another at Hollen Creek; and a final one at Bruyère Lake. A wetland managed by Ducks Unlimited Canada is also located at the northern border of the Project area, the Stadacona pond.

Fisheries and Fish Habitats

Since the Abitibi-Témiscamingue region hosts a large amount of lakes, rivers and creeks, the freshwater aquatic wildlife is relatively diversified. A total of 49 species are known to be present in the region's lakes and rivers (OBVT, 2011), among which the most abundant are: walleye, sauger, lake trout, brook trout, catfish, and northern pike (MRNF, 2006).

The most important rivers and lakes present in the Project area are the Pelletier and Bruyère lakes and the La Bruère and Beauchastel rivers. Other rivers (mostly creeks) and lakes are also present, but are of smaller size (ex. Gamble, Françoise and Ted lakes; Demers and Cousineau creeks).

Fisheries assessments were completed by the MFFP within the Beauchastel and La Bruère rivers as well as in Gamble Lake. No trout species were captured as part of those works. Species fished as part of those assessments are: white sucker, channel darter, logperch, trout-perch, catfish, and mottled sculpin. Except for the channel darter, those species are all typical at the regional level.

20.3.3.3 Special-Status Species

Based on data provided by the Centre de données sur le patrimoine naturel du Québec (CDPNQ), no special-status plant species are known to occur in the Project area. With regards to special-status wildlife

⁴ OBVT (Organisme de bassin versant du Témiscamingue). 2011. Portrait du bassin versant du Témiscamingue. Version 2010, mise à jour décembre 2011. Plan directeur de l'eau (PDE) du bassin versant du Témiscamingue. 220 p.

species, the CDPNQ databank identified two provincially-designated bat species (red and hoary bats) in the Pelletier Lake vicinity, about 3.5 km north-west of the projected mine site.

Based on information provided by the MFFP in its Regional Portrait (MRNF, 2006), a woodland caribou herd, a special-status species designated at both provincial and federal levels, is present in the vicinity of Val-d'Or, near the Decelles Reservoir (OBVT, 2011), about 100 km east of the Project area. It is important to note that the MFFP and the CDPNQ have not confirmed the presence of woodland caribou in the Project area when specifically asked about it. In fact, the Abitibi region is considered by the MFFP to be at the southern limit of distribution of this species in the province of Québec.

The bald eagle, a bird species designated as vulnerable at the provincial level, is also known to occur in the Pelletier Lake area, about 3.5 km north-west of the projected mine site.

Finally, the channel darter is designated as threatened at the federal level. In Canada, the channel darter's occurrence is uncommon, but fragmented populations exist in several areas of Ontario and Quebec. In Quebec, the species is found in the St. Lawrence River and also in tributaries of four hydrographic regions, among which the Ottawa River hydrographic region which includes the Rouyn-Noranda region.

20.3.3.4 Protected Areas

As previously mentioned, legally-designated wildlife habitats are located at the borders of the Project area, i.e. three waterfowl gathering areas and one muskrat habitat. Those two areas are protected under the Regulation respecting wildlife habitats. No other protected areas (ex. national parks, ecological reserve, exceptional forest ecosystem, etc.) are located in the Project area or its immediate vicinity.

20.4 MINING SITE REHABILITATION CONCEPTS

The rehabilitation and restoration plan concept is summarized as follows:

- Waste rock piles will be covered with a layer of top soil/overburden and revegetated when feasible.
- Haul roads surface will be scarified and revegetated.
- No building will be left in place. Whenever possible, buildings will be sold with the equipment they contain, completely or partially. During dismantling works, beneficiation/recycling of construction material will be maximized. Remaining waste will be disposed of in an appropriate site.
- All equipment and machinery will be disposed of or recycled off-site.
- The drinking water supply and domestic wastewater treatment facilities will be dismantled.
- Infrastructure relating to electricity supply and distribution will be dismantled with the exception of Hydro-Québec requirements.
- Once the mining activities cease, the pit will gradually fill up to its equilibrium level with rainfall and groundwater.
- Fences will be installed around the open-pits for security purpose
- Whenever possible, the surface water drainage pattern will be re-established to a condition similar to the original hydrological system.
- Waste material from demolition activities will be decontaminated when required, recycled when cost-effective or buried in an appropriate site.
- Facilities containing petroleum products, chemicals, solid waste, hazardous waste, and/or contaminated soil or materials will be dismantled and managed according to regulatory requirements.
- All hazardous waste will be managed according to existing laws and regulations and will be transported off site.

- As per to Directive 019 for the mining industry, a Monitoring Program will have to be implemented during the mine operation to account for all the requirements specified in that Directive, especially with regards to noise levels, vibrations, surface and ground waters.
- The physical stability of the waste rock piles will need to be assessed, and signs of erosion will be noted. This monitoring will be conducted on an annual basis for a minimum of five years following mine closure.
- Monitoring of the water quality (surface and groundwater) will continue for a minimum of five years after the completion of the restoration work.
- The agronomic monitoring program is designed to assess the effectiveness of the re-vegetation which will be done as part of mining rehabilitation efforts. To document the success of the re-vegetation efforts over the waste dumps areas, an agronomic monitoring will be undertaken following the establishment of a vegetative cover on the areas subject to the progressive restoration program. This monitoring will be conducted annually for three years following the revegetation efforts. Reseeding will be carried out, as required, in areas where re-vegetation is found unsatisfactory.

20.5 RELATIONS WITH STAKEHOLDERS

GBB has carried out consultations with:

- Authorities of City of Rouyn-Noranda, including the mayor;
- Representatives of the Rouyn-Noranda Snowmobile Association;
- Representatives of the Rouyn-Noranda School Board;
- Representatives of the Rouyn-Noranda Recreation Service.

Public presentations of the project have been held on February 26, 2014 and May 21, 2014. Participation of residents living in the area of the project has been important.

Finally, an information letter has been sent to the Timiskaming First Nation Council in Notre-Dame-du-Nord, 80 km south-west of Rouyn-Noranda.

21 Capital and Operating Costs

21.1 CAPITAL COSTS

The total capital expenditures cost (CAPEX) is estimated at an overall accuracy of $\pm 25\%$, which is the standard for a pre-feasibility study. The CAPEX was defined by SGS using in-house database, seller bids and the Mine & Mill Equipment Costs Estimator's Guide: Capital & Operating Costs (2012) annexed to 2014. The total required investment is estimated at 6.70 M\$. Please refer to the Table 21-1 for the CAPEX breakdown.

Table 21-1: CAPEX Summary

Item	Cost
Working capital (3 months guarantee)	\$ 3,500,000
Pre-production salaries	\$ 600,000
Overburden stripping	\$ 601,595
Initial capital (infras and other)	\$ 1,993,750
Total	\$ 6,695,345

This capital requirement does not include:

- Costs to obtain permits;
- Any provision for changes in exchange rates;
- GST/QST;
- Project financing and interest charges;
- Price/cost escalation during construction;
- Import duties and custom fees;
- Sunk cost;
- Exploration activities;
- Severance cost for employees at the cessation of operations;
- Any additional costs (but can partly be absorbed in contingency allowance).

21.1.1 WORKING CAPITAL

Considering that the processing plant that will treat the Granada ore will do so by batch, (ie. at each 3 months approximately), SGS considered a cost related to the working capital of 3.5 M\$ that will cover all mining activities for the first 3 months period.

21.1.2 PRE-PRODUCTION SALARIES

SGS considered that the operator will need a part of his staff prior the start of the mining operation and obviously prior its first gold payment. For this reason, SGS considered a provision of 0.60 M\$ that will cover the salaries of the key personal for a 6 month period in order to bring the project into production.

21.1.3 OVERBURDEN STRIPPING

SGS assumed that all the overburden covering the first isolated pit to be mined will be removed prior the operation. For this reason and as it often the case in a mining project, the overburden stripping is considered as capital expenditure. The cost of such a work is calculated at 0.60 M\$.

21.1.4 INITIAL CAPITAL

As presented in Table 21-2, the initial capital required is estimated at 2.00 M\$ and includes a contingency of 25.0%. This cost, detailed in the following Table 21-2, was developed from quotations received from

Supplier cost estimation guides and from experience and personal contacts within the mining industry; other sources of information are from an internal database on similar projects.

Table 21-2: Initial Capital

Camp	
<i>Sanitary facilities, installation and supervision</i>	\$ 100,000
<i>Furniture, paint and accessories</i>	\$ 15,000
Offices and Hardware	
<i>Trailers, installation and supervision</i>	\$ 150,000
<i>Offices goods</i>	\$ 15,000
<i>Computers + accessories</i>	\$ 20,000
<i>Softwares + training</i>	\$ 50,000
<i>Printers</i>	\$ 5,000
<i>Network + installation</i>	\$ 10,000
<i>Surveying equipment</i>	\$ 80,000
Pits dewatering	
<i>Application for C.A.</i>	\$ 20,000
<i>Dewatering project</i>	\$ 150,000
Mining equipment	
<i>Pick-ups trucks and accessories</i>	\$ 280,000
Infrastructures	
<i>Mechanical garage, used oil recuperation system and lift truck</i>	\$ 200,000
<i>Safety signs</i>	\$ 5,000
<i>Fuel tank set-up + concrete slab</i>	\$ 20,000
<i>Water sedimentation pond + water drainage</i>	\$ 75,000
<i>Ore stockpile, membrane and water drainage</i>	\$ 75,000
<i>Waste dumps site preparation</i>	\$ 60,000
Others	
<i>Approximately 1,200 meters of drilling</i>	\$ 150,000
<i>Rehabilitation of the pits and site preparation (ex. roads, etc.)</i>	\$ 65,000
Studies	
<i>Geotech drilling</i>	\$ 50,000
Sub-total	\$ 1,595,000
Contingency (25%)	\$ 398,750
Total cost	\$ 1,993,750

21.2 SUSTAINING CAPITAL COSTS

Each mining operation has to inject a certain yearly amount of investment, defined as sustaining capital costs, in order to keep its operation up and running, to respect regulations, etc. At the inverse of the

CAPEX, these cost are occurring after the start of the operation. SGS estimates this sustaining capital costs to 2.90 M\$ divided in 3 main items; financial guarantee for site rehabilitation, overburden stripping, and others. The Table 21-3 shows the estimated cost per year of operation.

Table 21-3: Estimates cost per year of operation

Year	1	2	3	Total
Financial guarantee for site rehabilitation	\$ 620,313	\$ 310,156	\$ 310,156	\$ 1,240,625
Overburden stripping	\$ 839,825	\$ 667,223	\$ -	\$ 1,507,047
Others (provision)	\$ 50,000	\$ 50,000	\$ 50,000	\$ 150,000
Total	\$ 1,510,137	\$ 1,027,379	\$ 360,156	\$ 2,897,672

21.2.1 REHABILITATION AND MINE CLOSURE CAPITAL COSTS

The cost for site rehabilitation and mine closure was developed by SGS and Roche. These costs shown in the Table 21-4 are mainly related to the permanent closure of the stockpiles and dismantling of site infrastructure. This cost has been calculated to 1.24 M\$.

Table 21-4: Cost for site rehabilitation and mine closure

Item	unit	Value
Reclamation cost	\$/m2	1.75
Reclamation cost (based on 500m x 500m)	\$	437,500
Overburden rehandling	\$/m3	4.75
Overburden capping (based 500m x 500m x 0.40m)	\$	475,000
Bumpers/fences to isolate the pits	\$	50,000
Characterization study (Phase 1-2-3) of contaminated soil	\$	50,000
Dismantling infrastructure	\$	-
10% provision for engineering	\$	91,250
Monitoring waste dump piles and water quality		36,875
Contingence	\$	100,000
Total	\$	1,240,625

It was assumed that the buildings will be sold at the end of the mine life and that the revenues will cover the cost of dismantling. Also, it is planned to make the progressive re-vegetation/rehabilitation and it is for this reason that the reclamation cost only is related to a 500m by 500m area.

For the purpose of this Study and to be in line with the actual regulation, it was assumed that this 1.24 M\$ would be spread over the 3 first years of operation as 50%, 25% and 25% respectively.

21.2.2 OVERBURDEN STRIPPING AND OTHERS

As the first year of overburden stripping was incorporated as a capital cost, SGS assumed that the remaining overburden will be treated the same, so it was considered as a sustaining capital cost.

An additional provision of 50,000 \$ per year was allowed for in the case of any unplanned expense.

21.3 OPERATIONAL COSTS

The total capital expenditures cost (CAPEX) is estimated at an overall accuracy of $\pm 25\%$, which is the standard for a pre-feasibility study. The CAPEX was defined by SGS using in-house database, seller bids and the Mine & Mill Equipment Costs Estimator's Guide: Capital & Operating Costs (2012) annexed to 2014.

The operating costs do not include:

- Any provision for inflation;
- Any provision for changes in exchange rates;
- GST/QST;
- Corporate administration and head offices costs; and
- Exploration activities.

21.3.1 MINING COST – HARD ROCK (WASTE AND ORE)

Mine operating costs were calculated using a list of equipment and manpower prepared by SGS. Mining operating costs include the leasing costs for the main mining equipments, the equipment operating cost, the salaries, the cost for blasting and other services. The equipment cost and blasting cost are based on Supplier's budgeted price and a fuel price of C\$1.30 per litre of fuel. Average salaries are based upon a discussion between SGS and Gold Bullion Development Corporation and include an average of 30% fringe benefits. Equipment unit operating and maintenance costs were developed from quotations received from Supplier cost estimation guides and from experience and personal contacts within the mining industry; other sources of information are from an internal database on similar projects. The global hard rock mining costs are summarized in the Table 21-5.

Table 21-5: Mining Cost Subdivision

Item	unit	Cost	
		Waste	Ore
Drilling	\$/t	0.40	0.79
Blasting	\$/t	0.64	1.29
Mucking	\$/t	0.49	0.49
Hauling	\$/t	1.27	1.27
Services	\$/t	0.59	0.59
Staff/others	\$/t	0.16	0.16
Total	\$	3.55	4.59

The construction of these is available at request.

21.3.2 MINING COST – OVERBURDEN

SGS assumed that the cost of mining the overburden material would be the same as waste mining but without the cost for drilling and blasting. Based in this assumption, SGS calculated the overburden mining cost at 2.51 \$ per tonne mined.

21.3.3 ORE LOADING

This task is planned to be performed by the transport contractor. Ore material will be mined from the pits and stored on-site prior transport to the processing plant. Based on contractors bids, SGS assumed an

ore loading cost of 1.25 \$ per tonne of ore. This cost includes the loading equipment operational cost as the operator salaries.

21.3.4 ORE TRANSPORT

This task is planned to be performed by the transport contractor. Ore material will be transported from the mine site to the processing plant, located approximately at 43 km, by highway trucks. Based on contractors bids, SGS assumed an ore transport cost of 4.75 \$ per tonne of ore. This cost is considered as all-inclusive.

21.3.5 ORE CRUSHING

From discussions with transport contractor, the highway trucks that will be transporting the ore material could transport blasted material of a certain size, (ie. There is no need to crush prior loading). However, it is planned that some rocks will be oversize. These rocks will be stockpiled separately and an excavator will break them using a hammer. A provision of 0.25 \$ per tonne of ore was assumed for this item.

21.3.6 ORE PROCESSING

As it was presented in Section 17, the cost of processing per tonne of ore including G & A is 51\$/tonne. For the purpose of this PFS, this cost is considered as all-inclusive.

According to requests from the Gold Bullion and lamgold, the processing cost should not be clearly stated in this report. However, SGS considered this cost in the economic analysis of the project.

21.3.7 GENERAL AND ADMINISTRATION (G&A)

The total G&A cost was calculated on a cost per tonne of ore through the life of the mine(included with the disclosed processing cost). This cost includes the salaries of the staff personal as well as other general expenses required to maintain the operating up and running. The following Tables (Table 21-6 and Table 21-7) present the construction of this cost.

Table 21-6: Staff Salaries

Description	Qty.	Salaries \$/year	Benefits 30%	Total \$/year	\$/tonne processed
Mine Engineering					
Chief engineer	1	\$ 120,000	\$ 36,000	\$ 156,000	\$ 0.78
Surveyor	1	\$ 75,000	\$ 22,500	\$ 97,500	\$ 0.49
Mapping technician	1	\$ 65,000	\$ 19,500	\$ 84,500	\$ 0.42
Geology					
Chief geologist	1	\$ 120,000	\$ 36,000	\$ 156,000	\$ 0.78
Assistant geologist	1	\$ 85,000	\$ 25,500	\$ 110,500	\$ 0.55
Technician	1	\$ 75,000	\$ 22,500	\$ 97,500	\$ 0.49
Administration					
Mine manager	1	\$ 130,000	\$ 39,000	\$ 169,000	\$ 0.85
Administrative assistant	1	\$ 65,000	\$ 19,500	\$ 84,500	\$ 0.42
Accountant clerk	1	\$ 50,000	\$ 15,000	\$ 65,000	\$ 0.33
Environmental technician	1	\$ 65,000	\$ 19,500	\$ 84,500	\$ 0.42
Warehouse responsible	1	\$ 75,000	\$ 22,500	\$ 97,500	\$ 0.49
Human resource	2	\$ 50,000	\$ 15,000	\$ 130,000	\$ 0.65
Driver	1	\$ 40,000	\$ 12,000	\$ 52,000	\$ 0.26
Sub-total	14	\$ 1,015,000	\$ 304,500	\$ 1,384,500	\$ 6.94
Contingencies - 10%				\$ 138,450	\$ 0.69
Total				\$ 1,522,950	\$ 7.63

Table 21-7: General costs

Items	\$/year	\$/tonne processed
Infrastructures maintenance/investment	\$ 40,000	\$ 0.20
Ongoing studies	\$ 75,000	\$ 0.38
Investment in local community	\$ 50,000	\$ 0.25
Electronic hardware	\$ 15,000	\$ 0.08
Software fees	\$ 10,000	\$ 0.05
Office supply, phone, internet, etc.	\$ 15,000	\$ 0.08
Informatical support (I.T.)	\$ 10,000	\$ 0.05
Insurances	\$ 10,000	\$ 0.05
Local taxes	\$ 15,000	\$ 0.08
Pick-ups operation	\$ 90,000	\$ 0.45
Offices cleaning	\$ 60,000	\$ 0.30
Ore assay + grade control	\$ 200,000	\$ 1.00
Ore selectivity	\$ 20,000	\$ 0.10
Sub-total	\$ 610,000	\$ 3.06
Contingencies - 10%	\$ 61,000	\$ 0.31
Total	\$ 671,000	\$ 3.36

21.3.8 NET SMELTER RETURN

As described in the previous sections, a 3.0 % net smelter return is applicable on gold sales.

22 Economic Analysis

22.1 PRINCIPAL ASSUMPTIONS

SGS made a numbers of assumptions in order to develop the Granada Project financial model:

- price of gold at \$1,400.00 CDN per ounce troy;
- 3.0% NSR is attributable to a third party;
- processing rate of 192,500 tonnes per year (equivalent to approximately of 550 tonnes per day);
- constant exchange rate of \$0.90 (CDN\$:US\$);
- discount rate of 5.00 %;
- sunk costs and owner’s costs are not included in the model;
- 3 years of mining operation;
- initial capital cost will be spend before the first year of production (year -1 in the model);

22.2 CASH FLOW FORECASTS

A summary of the base case results is given in the Table 22-1 and Table 22-2 while the detailed cash flow statement related to the base case scenario is presented after.

Table 22-1: Summary of the base case results

Item		Unit	Value
Total revenues		\$	102,700,000
Total operating costs		\$	65,100,000
Pre-production capital costs		\$	6,700,000
Sustaining capital costs		\$	2,900,000
Royalties paid		\$	3,100,000
Pre-tax	Undiscounted benefits	\$	28,400,000
	NPV discounted at 6.00 %	\$	24,700,000
	Internal rate of return	%	169.4%
	Payback period	months	0.6
After-tax	Undiscounted benefits	\$	22,700,000
	NPV discounted at 6.00 %	\$	19,500,000
	Internal rate of return	%	136.0%
	Payback period	months	0.8

Table 22-2: Detailed cash flow statement related to the base case scenario

			Year 0	Year 1	Year 2	Year 3	Total
Material Mined	Ore treated	tonnes		192,500	192,500	183,675	568,674
	Grade	g/t		4.37	4.69	3.63	4.24
	Processing recovery	%		95.00	95.00	95.00	95.00
	Ounces produced	oz		25,669	27,556	20,361	73,585
	Ore mined	tonnes		192,500	192,500	183,675	568,674
	Overburden mined	tonnes	239,679	442,103	158,315		840,097
	Waste mined	tonnes		2,571,864	3,449,868	2,418,110	8,439,843
Total mined	tonnes	239,679	3,206,467	3,800,683	2,601,785	9,608,935	
Stripping ratio	t:t		15.7	18.7	13.2	16.3	
Operational Revenues	Ounces produced	oz		25,669	27,556	20,361	73,585
	Gold price	Cdn\$/oz		1,400	1,400	1,400	1,400
	Payable	%		99.935	99.935	99.935	99.935
	Charges	Cdn\$/oz		3.00	3.00	3.00	3.00
	Revenues	\$		35,836,542	38,470,069	28,425,305	102,731,916
Operational Charges	NSR (3.00 %)	\$		1,075,096	1,154,102	852,759	3,081,957
	Ore mining (4.59 \$/t)	\$		883,575	883,574	843,067	2,610,215
	Waste mining (3.55 \$/t)	\$		9,130,118	12,247,033	8,584,291	29,961,442
	Ore loading (1.25 \$/t)	\$		240,625	240,625	229,593	710,843
	Ore transport (4.75 \$/t)	\$		914,375	914,374	872,455	2,701,203
	Ore crushing (0.25 \$/t)	\$		48,125	48,125	45,919	142,169
	Ore processing + G&A (51.00 \$/t)	\$		9,817,500	9,817,485	9,367,409	29,002,394
Total charges	\$		22,109,415	25,305,316	20,795,493	68,210,224	
Cash cost per ounce (free of NSR and ovb mining)		\$/oz		819	876	979	885
CAPEX & Sustaining CAPEX	Initial capital	\$	1,993,750				1,993,750
	Working capital (3 months guarantee)	\$	3,500,000			- 3,500,000	-
	Pre-production salaries	\$	600,000				600,000
	Overburden stripping	\$	601,595	1,109,678	397,370		2,108,642
	Others Sustaining capital	\$		670,313	360,156	360,156	1,390,625
	Total	\$	6,695,345	1,779,990	757,526	- 3,139,844	6,093,017
Pre-Taxes Project Profits		\$	- 6,695,345	11,947,137	12,407,227	10,769,655	28,428,674
Taxes		\$		2,088,085	2,336,285	1,275,183	5,699,554
After-Taxes Project Profits		\$		9,859,052	10,070,941	9,494,472	22,729,121

22.3 NET PRESENT VALUE, INTERNAL RATE OF RETURN AND PAYBACK PERIOD

The financial analysis results of the Granada Project for the base case scenario are calculated as:

- 24.7 M\$ net present value (19.5 M\$ after tax) at 6.00 % discount rate;
- 169 % internal rate of return (136 % after tax);
- 6.0 months payback period (8.5 months after tax).

22.4 TAXES, ROYALTIES AND INTERESTS

22.4.1 TAXES

The Granada Project will be subject to current and planned Federal and Quebec tax rates and related tax rules. At the date of this report, the applicable tax rates are:

Federal income tax rate:	15.0 %	
Provincial income tax rate:	11.9 %	
Quebec mining tax:	16.0 %	(Quebec levies mining taxes under the Mining Tax Act at a flat rate of 16.0 % since 2012 for all material extracted from Quebec soil)

A mining corporation in Quebec will be subject to mining taxes on the annual profit earned on its property that is reasonably attributable to the mine and that can be reasonably be attributable to the operations of the mine. For the purpose of the Mining Tax Act, annual profit is determined by subtracting from gross revenue the operating expenses and allowances directly related to the mine, including:

- exploration and development expenses;
- depreciation;
- a processing allowance;
- an additional allowance for a mine located in the North or mid North (not applicable).

Important note:

On May 6th 2013, the Quebec Government has tabled legislation that modifies the royalty/tax regime associated to the mining industry. According to documents submitted by the Government, the new mining royalty regime will ensure that all operators (mining companies producing cash flow) have to pay a minimum tax based on revenue. The new regime proposes the imposition of an additional minimum royalty based on the value of the ore extracted by a mining company from the Quebec soil (run-of-mine ore). If the production value is less than 80 M\$, the royalty will amount to 1% and if the production value is greater than 80 M\$, the royalty will be 4% of the value of the ore mined. In addition, the Quebec Government proposes to implement a progressive mining tax rate (instead of actual flat rate of 16 %) for companies that generate profits and that will not be subject to the minimum royalty. The mining tax will be 16% if the profit margin of the company is between 0% and 35%. If profit is between 35% and 50% the tax will be 17.8% and if the profit is between 50% and 100%, the tax will be 22.9%. This represents tabled legislation by the Government which will need to be voted into law before it can be implemented. If accepted, the new tax regime is expected to be implemented in 2014.

The tax model that was presented in previous section was prepared by an accountant from Deloitte in Rouyn-Noranda. In order to come up with an estimation of the possible taxes, the following assumptions were made:

- The Granada project is a new mine for tax purposes, there were no production in commercial quantities in the past on the property;
- The expense incurred in the years considered will not be renounced in favor of FTS investors;
- The year one occurs in 2014;
- The income for tax purposes is based on the information that appear on the mine plan cash flow worksheet;

- The commercial production begins on year 1;
- All the depreciable assets incurred before year 1 relates to a new mine and are situated on the site of the mine;
- Only for the taxation purpose, the overburden incurred in year 1 has been considered as expenses engaged for the purpose of developing the mine and as a operating expense for the other years;
- The drilling campaign and miscellaneous has been considered as operating expense;
- The financial guarantee has been considered has an expense in year 3;
- All the development expenses (year 0) except depreciable assets are incurred for the purpose of bringing a new mine in production in reasonable commercial quantities but before the beginning of such production;
- All the expenses are not deductible expenses for mining duty tax purposes because they are considered as per 8.0.1 of the law as "an expense, except to the extent that it was incurred by the operator in respect of a mining operation to realize the gross value of the annual output from the mining operation and provided that the expense relates directly thereto" or "an expense incurred for constitution, organization or reorganization or other non deductible expense mentioned in section 8.0.1. of the law".
- 50 % if the G&A expenses were considered as non deductible expenses for mining tax purposes;
- The income tax rate is 26.9% (2012 federal and Québec tax rate);
- The entity does not operate any mine nor any related party to it;
- The depreciable assets are considered not in use during preproduction period;
- The beginning of year tax pools (CEE - CDE) and tax credit are related to the Granada property so that we used the past year expenditures to reduce the income tax burden;
- There is no administration expenses related to exploration;
- The entity is an eligible operator till year 1.

22.4.2 ROYALTIES

A 3.00 % NSR is applicable to the Granada project and has been considered in the present economic analysis.

22.4.3 DEBT AND INTERESTS

SGS has for opinion that a PFS should measure the inherent value of a mineral project, not the ability of an owner to finance a project on favourable terms. For this reason, the economical analysis presented in this study is supposing 100% equity cashflows, so no interest attributable to capital financing was considered.

22.5 SENSITIVITY ANALYSIS

The sensitivity of the Net Present Value (NPV) and the internal rate of return (IRR) were evaluated for changes in key variables and parameters such as:

- Capital investment (CAPEX);
- Gold price;
- Operating cost;
- Head grade;
- Processing recovery.

For simplification purpose, this sensitivity was prepared using only the pre-tax values. The result of the sensitivity is presented by the next Figure:

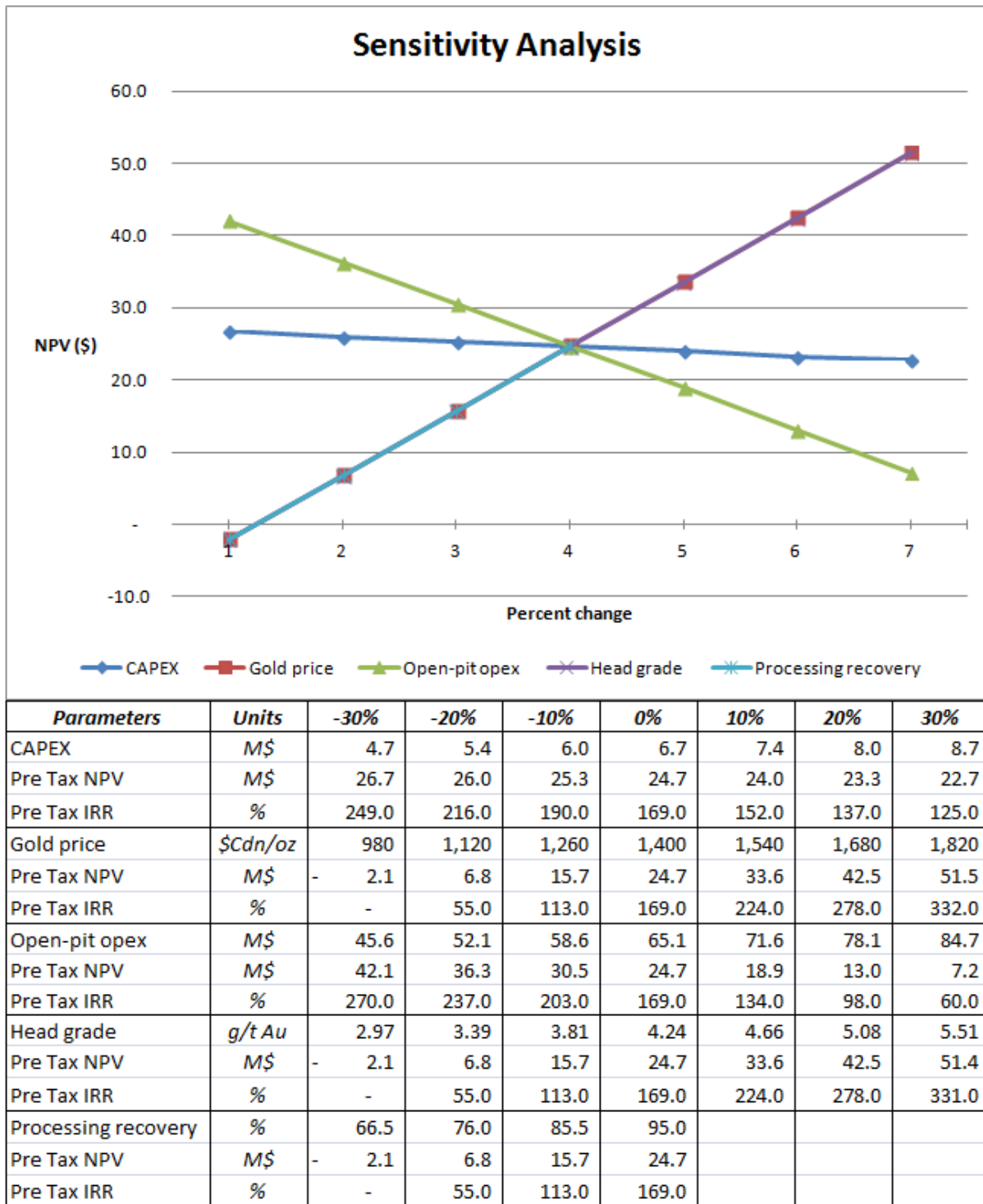

Figure 22-1: Sensitivity analysis

It can be seen that the gold price, the head grade and the processing recovery have the greatest impact on project NPV and IRR. The project becomes uneconomic when the gold price, the head grade or the processing recovery drops by about 27.5 %. Overall, the project is sensitive to each of the major variables. This sensitivity analysis clearly demonstrates that the gold price needs to remain over 1,000 \$CDN/oz troy; in order to keep the project economically viable.

23 Adjacent Properties

In Abitibi, most properties on the Cadillac trend are surrounded by others. The Gold Bullion Property is not an exception. The following map presents the property in red surrounded by others, most of them being public companies. Since the majority of these companies are active and have a public web site the author recommends the reader to visit their websites for the most recent information and developments.

- The adjacent property close to the known mineralized zone of Granada belongs to Adventure Gold. No declared work from their side on this property named Granada Extension.
- To the north the Astoria property of Yorbeau has declared resource statement in 2005 in the 700,000 to 1 Million gold ounces range. The resource is in a different geological context associated with the Cadillac fault. The technical report can be downloaded from their web site. The author is aware Yorbeau is conducting some diamond drilling on their property in 2014.
- To the north east Threegold Resources Inc. has discovered a mineralized trend along the Adanac Shaft, a figure from their web site is presented on the next page.
- RT Minerals is North East between Threegold and Gold Bullion close to McWatters, no recent work disclosed on the web site.
- No data could be found on the western side for Mines d'Argent Ecu Inc.

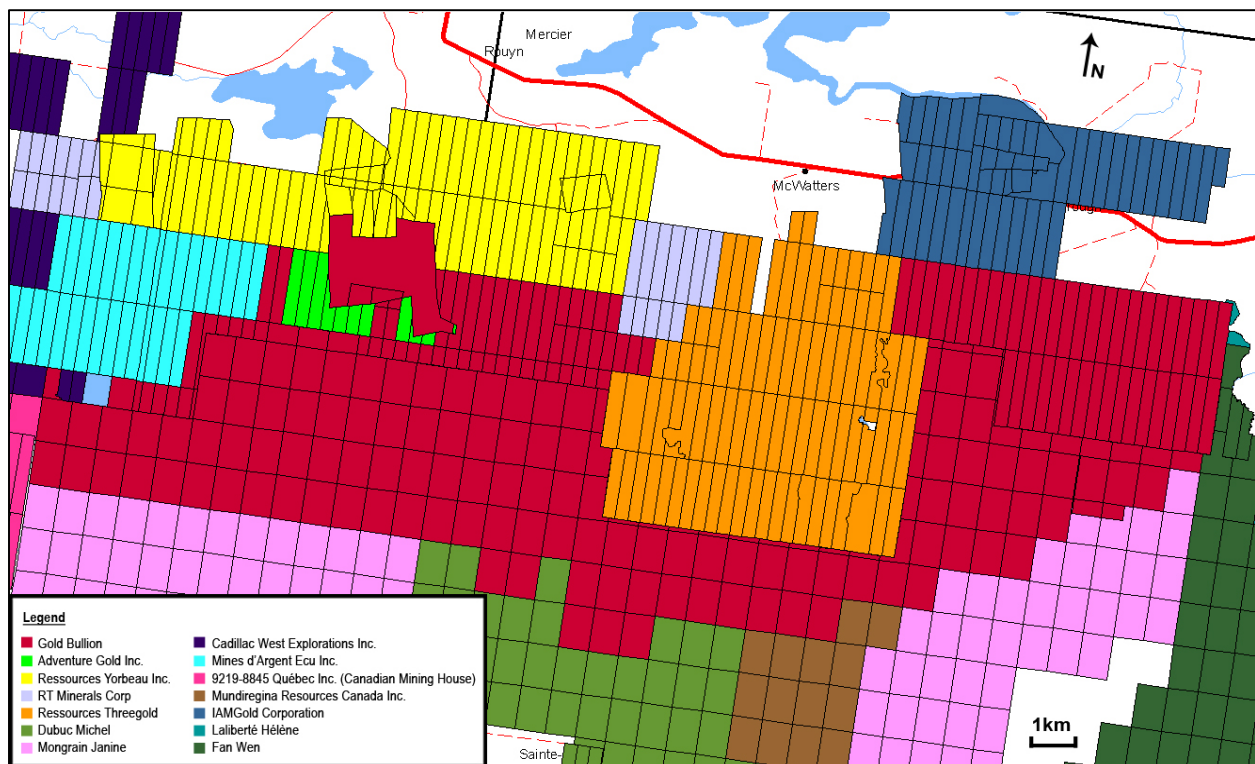

Figure 23-1: Map with adjacent properties (from MRN GESTIM)

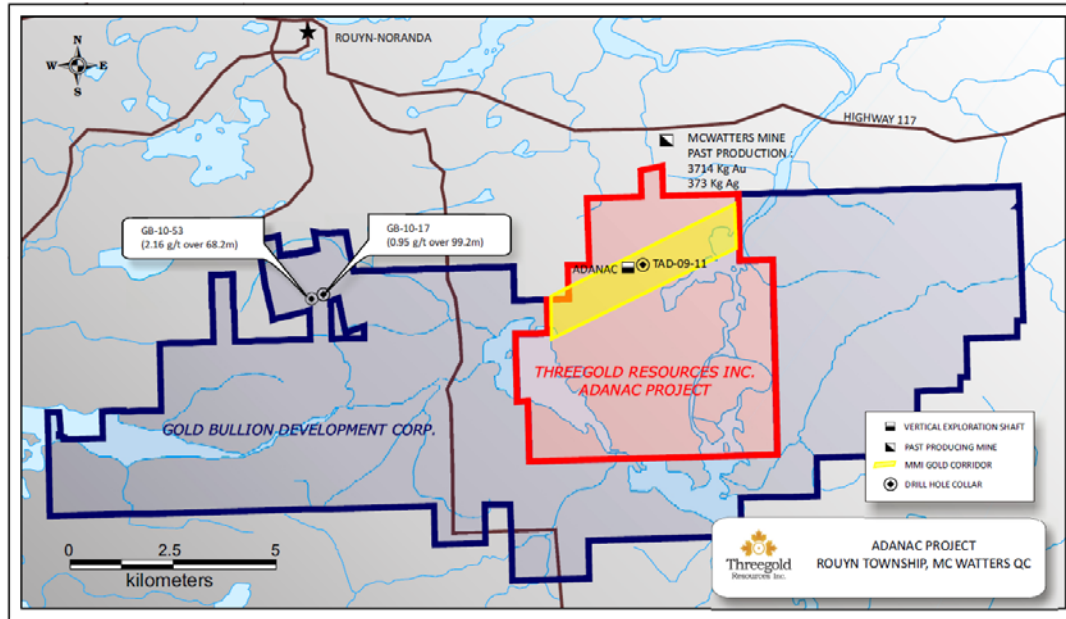

Figure 23-2: Adjacent property Adanac project (source Threegold Resources Inc. web site)

24 Other Relevant Data and Information

The author is aware that the owner of the mill at Granada has dismantled the mill.

Regarding the onsite waste pile, legacy of previous open-pit operations, Gold Bullion can use the rock for access road construction and it is also being used by local contractors for fill. An application for a Certificate of Authorization (C of A) is underway for the use of this material. Galarneau has just received its C of A to crush and screen aggregate. He has a contract 70,000 tonnes and to the author’s knowledge has a C of A for this independent operation but the Company needs another C of A for the remaining fines which is being prepared by Goldminds Geoservices with SODAVEX.

Photonic Knowledge has conducted core mapping and information is not for public disclosure. The author has not relied on the core scan information from Photonic Knowledge to prepare the resource estimate.

Note: At the moment of completing this report, final discussions on the custom milling agreement were underway. In the author’s opinion (Claude Duplessis, Eng.) who have participate in providing the technical information between the parties and continuous discussions between responsible of IMG & GBB, there is actually no reason to believe that the custom milling agreement between IMG & GBB should not take place and believe it should be signed within the next 2 to 3 weeks to the latest.

24.1 PROJECT SCHEDULE

SGS judged relevant to prepare a schedule that will show the next tasks or items to be completed in order to bring the Granada deposit into production. This schedule was prepared using Microsoft Project and is presented below:

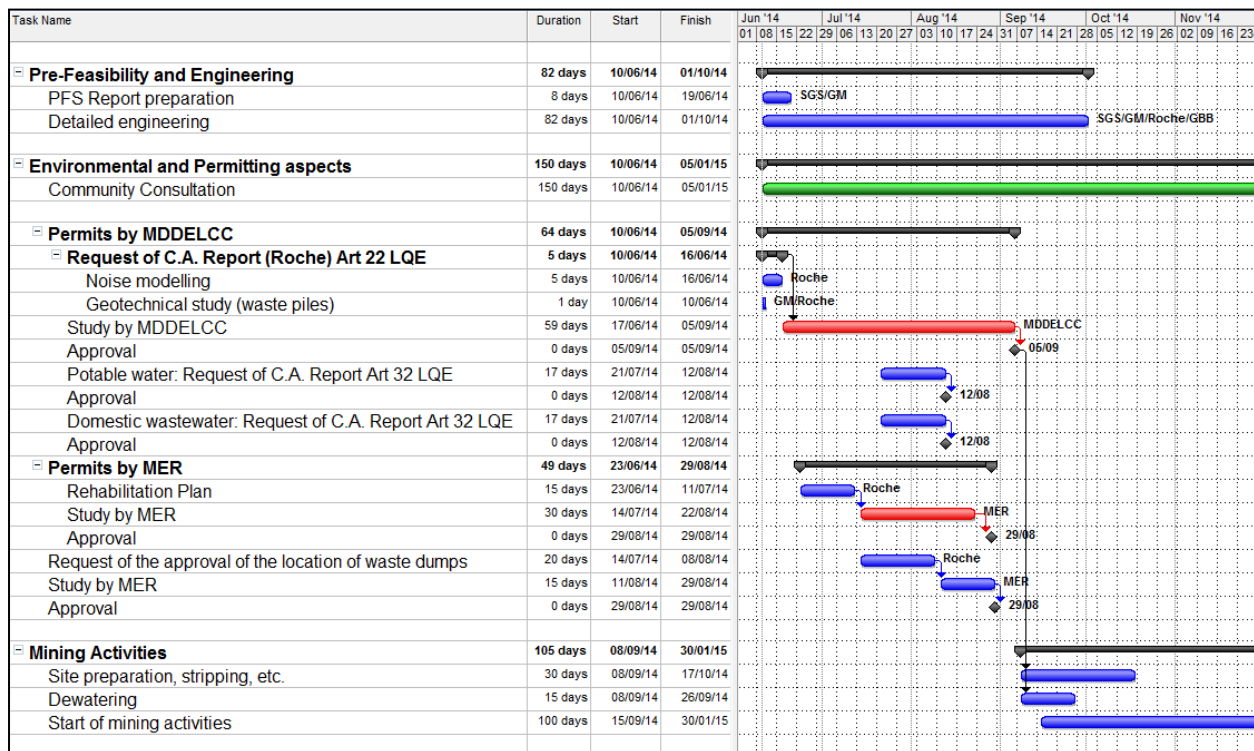

Figure 24-1: Project Schedule

25 Interpretations and Conclusions

25.1 CONCLUSIONS REGARDING THE ESTIMATION OF MINERAL RESOURCES

In the context of re-engineering to increase robustness of the Granada project, Mineral resources have been remodeled with mineral zones having a minimum horizontal width of 7m down to elevation 237.5m. This resource model has been used for pit optimization and design for the “Rolling Start” project. This model starts from the surface and pit bottom to elevation 237.5 metres. Lower grade is now excluded from the mineral resource statement. No gold loss has occurred from the PEA resource model to the actual presentation. It is all a matter of the mineral cut-off grade used with the associated economic scenario.

In order to address mining underground, mineralized zones have been remodeled with 3 to 4 meters horizontal width below elevation 237.5 metres. Highlights include a Measured and Indicated combined underground gold resource of 325,450 ounces of gold at an average grade of 5.10 g/t gold plus 25,700 ounces Inferred at a grade of 7.14 g/t gold. The combined underground measured resource is 107,600 ounces (763,500 tonnes grading 4.38 g/t), indicated resource is 217,600 ounces (1,221,000 tonnes grading 5.54 g/t), inferred resource is 25,700 ounces gold (112,000 tonnes grading 7.14 g/t Au) using a cut-off grade of 0.40 g/t.

Previous small open pits have been taken into account and are starting surfaces of optimization. The historical production of 51,476 ounces (181,744 sT @ 0.28 oz/sT) from 1930 to 1935 is included in the resource statement and the author cannot physically remove it from the measured, indicated or inferred categories. As the historical opening cannot be placed in 3D. Moreover the historical mining apparently extent to the west where no mineral resources have been estimated due to impossibility to drill from old tailing surface. The author also wants to remind that grade estimations comes from Gold Bullion recent drilling, hence gold grades do not comes from historical data in the mined out sector.

- Accuracy of the disclosure on what has been mined out underground. The amount of material mined out is limited, however it could be a bit more than disclosed but not to a huge extent since it would be reflected with a much larger tailing footprint.
- Combination of additional factors which could materially affect the resources are:
 - The presence of old orphan tailings
 - The presence of arsenic in the rock at Granada

25.2 MINERAL RESERVES ESTIMATES

The mineral reserve (with dilution and ore loss) is equal to 569,000 tonnes of ore at an average grade of 4.24 g/t Au using cut-off grades of 1.69 g/t and represents an operation of 3.0 years. The entire reserve comprises 77,500 ounces of gold (before processing recovery). Total waste, including rock, inferred resources and overburden, is 9.3 Mt; resulting in a waste to ore ratio of 16:3. The detailed mineral reserve estimate is shown in Table 25-1:

Table 25-1: Granada Project Reserves (presented as mill feed)

Material Type		Cut-off g/t Au	Material tonnes	Grade g/t Au	Au** ounces
Ore*	Proven Reserves	1.69	170,000	3.72	20,500
	Probable Reserves	1.69	399,000	4.46	57,000
	Total	1.69	569,000	4.24	77,500

* Presented as mill feed (with 25 % mining dilution and a 10% ore loss)

** Presented as mill feed (before processing recovery)

This reserve is dated to the effective date of this report. Reserves are based on a cut-off grade and there is always a possibility that the cut-off grade varies over time. The majors factors that could affect the cut-off grade, and thus directly the ore reserves, are a change in the gold price, a change in the processing recovery, a change in the operating costs (such as processing, G&A, transport, etc.), a different mining dilution that the one used in this report, etc.

25.3 MINING METHODS

The mining of Granada deposit will follow the standard practice of an open-pit operation with the conventional drill and blast, load and haul cycle, using a drill / truck / excavator mining fleet, and supported by a fleet of auxiliary equipment. The run-of-mine (RoM) will be drilled, blasted and loaded by hydraulic excavators and delivered by trucks to an ore stockpiling area. The ore will then be loaded onto transport trucks and delivered to the lamgold processing plant, approximately 43 km from the mine site. Waste rock material will be hauled to the waste disposal areas near the pits or backfilled into the mined pits. It has been assumed that the mining of the Granada deposit will be carried out by a mining fleet that will be leased and maintained by the Owner. The main mining fleet will consists of hydraulic excavators of 5 tonnes bucket capacity, and 35 tonnes off-road trucks.

A mine production schedule was prepared for the development and the operation of the Project. The mining production schedule for the open pit is based on a pre-stripping period of approximately 3 months. Key findings include:

- Project life of 3 years, with an ore mining rate of approximately 550 tonnes per day;
- Mill feed over the Project life of 569,000 tonnes at 4.24 g/t Au;
- Gold production of 73,600 ounces.

The proposed schedule for the open-pit operations is based on two 8-hour shifts per day, 7 days a week and 350 days per year. The selection of two 8-hour shifts is based mainly on the fact that this schedule will avoid any possible disturbing of the neighborhood during the night.

During this study, SGS came to the conclusion that the riskier item associated to mining is the control of the mining dilution during the operations. The ore zones are relatively thin following a 45-55 degrees dip and are favorable to an important dilution. In this study, SGS estimated the dilution to 25% at a gold grade of 0.00 g/t. Based on our experience and on similar operations, these estimates are judged acceptable but a considerable effort will be required during the operations to achieve these values. The effect of an increase in mining dilution is to lower the average mill feed grade and directly affect the project profitability. As is can be seen in the sensitivity analysis, the overall project profitability is extremely sensitive to the mill feed grade. SGS recommends to pursue the analysis of calculating the mining dilution during a feasibility study by considering various approaches such as lower the height of the benches in ore material, do in-fill drilling, increase the assaying of the ore zones, control and follow the ore blasts movements, etc.

Another aspect that requires attention is the old underground openings. It has been since 1930 that the Granada project is sporadically mined. Consequently, old underground excavations are present and need to be considered if mining is re-started. The first pit is in a Greenfield zone where no underground mining has proceeded. It is scheduled to proceed with 3D scanning of openings and survey once water level allows access to the openings. Old underground drift location have been put in plan but exact position are not considered exact for the mining operation and the company should complete a detailed survey once access is possible using laser scanner, surface survey with GPR to model openings. Procedures will have to be put in place for the accurate survey of the openings before getting into their vicinity. As the mining width of the old time is relatively thin and no huge openings are present in documents, the procedure should be relatively simple and limited ore drop to the level should occur. It is important to mention that as per existing information only a portion of the bottom of the pit to the west should cross small underground openings.

25.4 RECOVERY METHOD

The milling of the Granada ore is straightforward and SGS Geostat does not foresee any particular milling problems. The Iamgold-Doyon mill having a nominal capacity of 3,200 tpd is in operation and has been since early 1980 and enjoys an excellent reputation. Because of the mill feed rate and the Granada ore characteristics, some minor adjustments will have to be made to the mill. The most important being the volume of grinding balls in the SAG and ball mill, the number of cyclones and the number of leaching tanks (CIL) to be used. Since these adjustments have probably already been implemented for the milling of the Westwood ore, no other major changes to the mill are foreseen at this time.

25.5 ECONOMIC ANALYSIS

The financial analysis results of the Granada Project for the base case scenario are calculated as:

- 24.7 M\$ net present value (19.5 M\$ after tax) at 6.00 % discount rate;
- 169 % internal rate of return (136 % after tax);
- 6.0 months payback period (8.5 months after tax).

The principal assumptions made in order to obtain these values are the following:

- price of gold at \$1,400.00 CDN per ounce troy;
- 3.0% NSR is attributable to a third party;
- processing rate of 192,500 tonnes per year (equivalent to approximately of 550 tonnes per day);
- constant exchange rate of \$0.90 (CDN\$:US\$);
- discount rate of 5.00 %;
- sunk costs and owner's costs are not included in the model;
- 3 years of mining operation;
- initial capital cost will be spent before the first year of production (year -1 in the model);

In order to assess the sensitivity of the Net Present Value (NPV) and the internal rate of return (IRR) of the project, SGS varied the key variables that had the biggest chances to affect the project economic, i.e. the Capital investment (CAPEX), the Gold price, the operating cost, the head grade and the processing recovery. For simplification purpose, this sensitivity was prepared using only the pre-tax values. The result of the sensitivity is presented by the Figure 25-1:

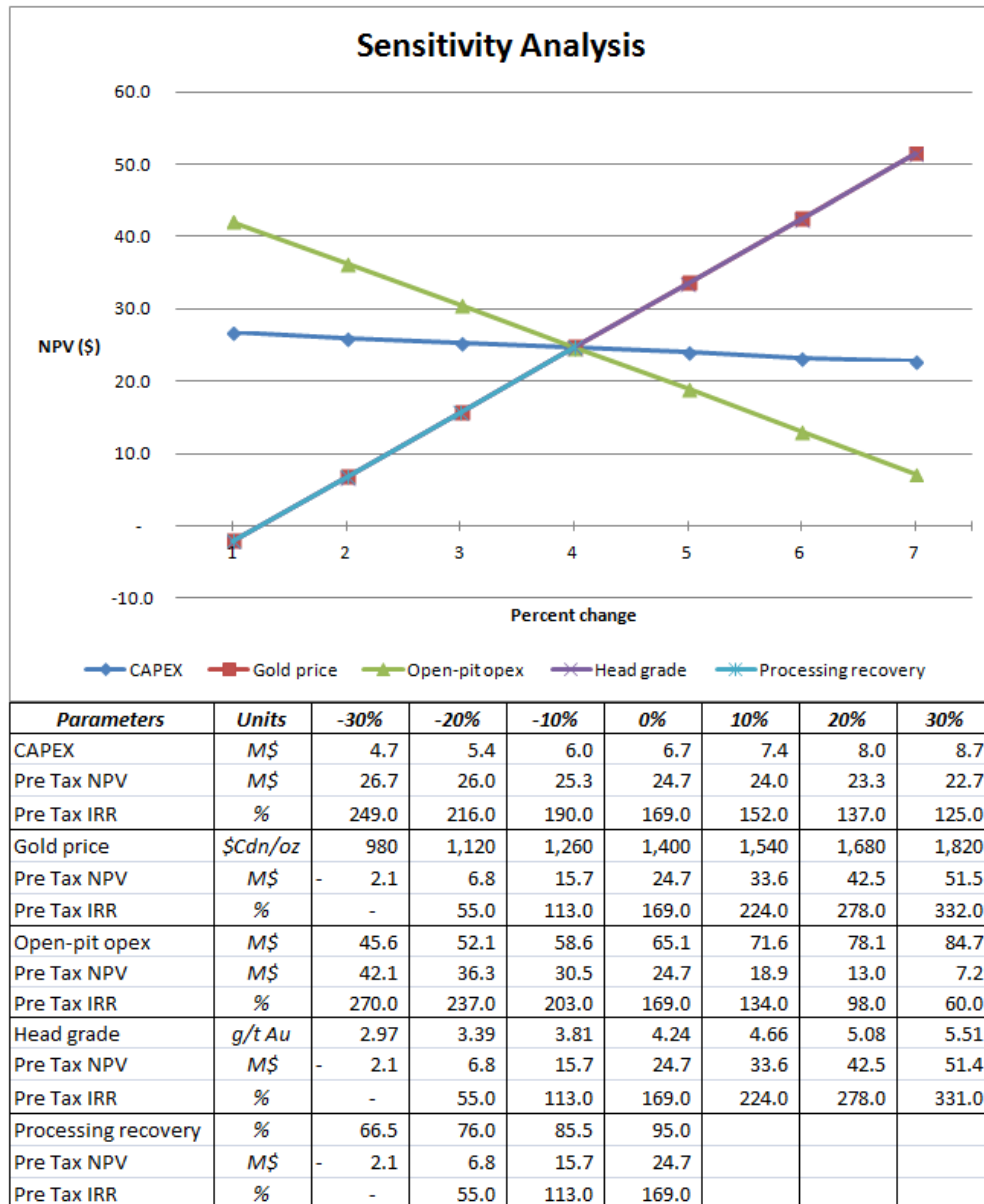

Figure 25-1: Sensitivity analysis

It can be seen that the gold price, the head grade and the processing recovery have the greatest impact on project NPV and IRR. The project becomes uneconomic when the gold price, the head grade or the processing recovery drops by about 27.5 %. Overall, the project is sensitive to each of the major variables. This sensitivity analysis clearly demonstrates that the gold price needs to remain over 1,000 \$CDN/oz troy; in order to keep the project economically viable.

26 Recommendations

26.1 RECOMMENDATIONS REGARDING THE ESTIMATION OF MINERAL RESOURCES

It is recommended to undertake negotiation and clean-up of the orphan tailings (dating from 1935) with the Ministry of Natural Resources Quebec in order to enable exploration drilling to the northwest of existing drilling to validate extension of the mineralized package at depth (old tailings location). It is also recommended to do additional drilling to improve resource estimates in the open pit area lateral extension. It is also recommended to complete the drilling to the west, to the north and to the east on a 40 to 50 m grid of surface holes drilling southward at 55 degrees dip. A few infill holes where gap exists and 3 cross-sections of 3 holes on 100 m line to tests mineralization on the claims to the west. There are 3 target depths which merit additional drilling. One is near surface which we can define as 0-100, from 100 to 400 meters and deeper which is 400 to 1000 meters vertical depth, The deep drilling of 2012, the DUP holes have confirmed extension of gold mineralisation at 1Km vertical depth showing the system is still open. The author also wants to mention that the property has not been explored extensively by diamond drilling and some budget should be put on testing extensions when the economic conditions allows for that type of work.

The exploration work program & others – Step 1 – 2014/2015 is estimated as follow:

Exploration Budget on the Granada Project (CAN\$)

Trenching (exploration)	\$75,000
Drilling (definition, exploration (0-400m))	\$2,500,000
Geotech Drilling (try to increase pit slope)	\$75,000
Laboratory met testings	\$50,000
Supervision and Technical reports	\$150,000
Deep drilling program Phase 2 targeting mineralization depth (400-1000m)	\$5,000,000
Estimated total cost	\$7,850,000

26.2 MINING

The Granada PFS is comprised of mining work that has been selected, designed and estimated in a way to meet industry standards. For this level of study, SGS has provided a mining plan for the future operation. SGS provide a list of recommendations, which would be beneficial if contemplated during detailed engineering phase. These mining engineered recommendations include:

- Developing strategic mine schedule in short-term detail (quarterly, monthly);
- Identifying opportunities for in-pit dumping;
- Review the estimation of the mining dilution and ore loss with a detailed mining approach for ore material;
- Complete a geotechnical study to optimize the open-pit slopes;
- Perform trade-off study for mining equipment selection and size;

- Consider the underground mining method as a serious alternative;
- Perform trade-off study to outline the optimal transition between open-pit and underground mining.

The authors recommend to Gold Bullion to proceed with the development of the project conditional to the recommended program of work which includes: definition and geotechnical drilling specific to the pit, in addition to the detailed engineering while permitting process takes place.

26.3 RECOVERY METHOD

Unless between batches the mill is stopped and thoroughly emptied of all ore, solid and liquid, there is no other choice but to accept some mixing of ores and other in-process material from different mines. Experience has shown that if clashes arise between a client and a mill owner it is most of the time related to the mill survey and sampling between these batches. SGS Geostat recommends that GBB has at all time a representative in the mill while milling the Granada ore.

Because of the coarse free gold particles in the ore, all effort should be made to pass all of the secondary cyclones underflow through the 30” Knelson concentrator. Even if the IMG-Doyon leaching circuit is very efficient, SGS is of the opinion that the gold trapped early in the circuit cannot be lost later at the leaching.

Just in case that for some reason IMG or GBB decides not to have the Granada ore custom milled or sometime in the future to discontinue the milling of the ore, the pre-feasibility report already started writing for the mill on site should be resumed.

26.4 ENVIRONMENTAL STUDIES, PERMITTING AND SOCIAL OR COMMUNITY IMPACT

Regarding the environmental issues, the recommendations are:

- Carry out kinetic testing (humidity cells or column) in order to determine the real metal leaching/acid rock drainage potential of the ore. The static testing performed is not conclusive (uncertainty regarding ARD potential according to Price (2009) classification used in the rest of Canada;
- Prepare a request of Certificate of Approval for the beneficiation of the waste rocks according to the «Guide de valorisation des matières résiduelles inorganiques non dangereuses de source industrielle comme matériau de construction».
- Continue the contacts with the stakeholders.

The environmental studies, permitting and social or community impact program is estimated as follow:

<u>Environment Studies, Permitting and Social or Community Impact Budget the Granada Project</u>		<u>(CAN\$)</u>
	Costs of kinetic testing (2)	\$30,000
	Cost for application of Certificate of Authorization for valorisation and testing	\$25,000
	<u>Estimated total cost</u>	<u>\$55,000</u>



27 References

- Charlton, J.D, 1984:** The Granada Mine of Kewagama Gold Mines Ltd and Goldsearch Inc., Geology, Ore reserves and Exploration Possibilities, Sulpetro Report, September 1984.
- Earth Metrix, 2011:** Geological and Structural study of the D2/D3 Group property Project, report prepared for Gold Bullion Development Corporation, June 2011.
- Gekko Systems, 2013:** Test Work Report T1037, Gold Bullion Granada Project, July 13, 2013
- Howe A.C.A, 1994:** Geology and Reserve Assessment of the Granada Gold Mine, report prepared for KWG Resources Inc., April 1994.
- OBVT (Organisme de bassin versant du Témiscamingue), 2011:** Portrait du bassin versant du Témiscamingue. Version 2010, mise à jour décembre 2011. Plan directeur de l'eau (PDE) du bassin versant du Témiscamingue.220 p.
- Photonic Knowledge, 2012:** Core Mapper summary memo 2012.
- Price, W.A. 2009:** Prediction Manual for Drainage Chemistry from Sulphidic Geologic Materials. Natural Resources Canada.
- Savoie, A., Morel, R., and Ferland, F., 2012:** Westwood Project, Quebec Canada, NI43-101 Technical Report, Mineral Resources and Reserves Estimate as of December 31st, 2012.
- SGS Canada Inc. Duplessis, C., 2012:** Technical Report, Granada gold project resource estimate, Rouyn-Noranda, Québec, April 2nd 2012.
- SGS Canada Inc. Duplessis, C., 2013:** Technical Report, Preliminary Economic Assessment (PEA) Granada Gold Project, Rouyn-Noranda, Québec, February 4th 2013.
- SGS Mineral Services, 2012:** An investigation into the determination of the gold head grades of composite samples from the Granada project. Project 13526-001, March 8, 2012.
- SGS Lakefield, 2012:** An Investigation into the determination of the gold head grades of composite samples from the Granada Project prepared for SGS Geostat for Gold bullion Development Corporation, Project 13526-001, final report, March 8, 2012.
- SGS Lakefield, 2012:** An Investigation into gold recovery from the Granada Project samples prepared for Gold Bullion Development Corporation, Project 14041-001, final report, May 2, 2013.
- Robinson, D., 2006:** Technical Report for the Granada Mine Property, Rouyn Township, Quebec, and Report prepared for Consolidated Big Valley Resources Inc., October 2006.
- RSW-Béroma Inc., 2000:** Évaluation du Potentiel Minéral de la Propriété Granada, Report prepared for Mousseau Tremblay Inc., June 2000.

-
- The European Journal of Mineral Processing and Environmental Protection, 2003:** Cyanide destruction: full-scale operation at Ovacik Gold Mine. Vol. 3, No. 3, 1303-0868, 2003, pages 270-280. E. Koksai, G. Ormanoglu, E.A. Deveuyt.
- URSTM, 2013:** Preliminary Report PU-2013-09-835-B, Metallurgical tests on Granada ore, report presented to Mr Frank Basa, Gold Bullion Development Corporation, by Jean Lelievre, October 31, 2013.
- Wetmore, D.L, 1982:** Goldsearch Inc. Interim Report on the Granada Property, Rouyn Township, Quebec, February 1982.

Electronic References

The Ministry of Natural Resources and Wildlife of Quebec (MNR):

<http://www.mrnf.gouv.qc.ca/english/home.jsp>

Gestim:

https://gestim.mines.gouv.qc.ca/MRN_GestimP_Presentation/ODM02101_login.aspx

Sedar website:

www.sedar.com

Appendix-1: Certificates of Qualified Person

Claude Duplessis, Eng., and qualified person

Gilbert Rousseau, Eng., and qualified person

Jonathan Gagné, Eng., and qualified person

Martin Stapinsky, P.Geo., M.Sc., Ph.D., and qualified person

Certificate of Qualified Person

I, Claude Duplessis Eng., do hereby certify that:

1. I am a senior engineer and consultant with SGS Canada Inc. – Geostat with an office at 10, Blvd de la Seigneurie East, Suite 203, Blainville, Quebec, Canada, J7C 3V5 under GoldMinds Geoservices Inc.;
2. This certificate is to accompany the Report entitled: "Technical Report, Prefeasibility Study (PFS) Phase I – Open Pit Granada Gold Project, Rouyn-Noranda" dated June 19th 2014;
3. I am a graduate from the University of Quebec in Chicoutimi, Quebec in 1988 with a B.Sc.A in geological engineering and I have practiced my profession continuously since that time, I am a registered member of the Ordre des ingénieurs du Québec (Registration Number 45523). I am also a registered engineer in the province of Alberta (Registration Number M77963). I have worked as an engineer for a total of 24 years since my graduation. My relevant experience for the purpose of the Technical Report is: Over 20 years of consulting in the field of Mineral Resource estimation, orebody modeling, mineral resource auditing and geotechnical engineering. I have specific experience in modelling and estimation of gold resources for Metanor Barry deposit, New Gold Mali Bagama, Duparquet project for Osisko, AKKA Gold for Managem in Morocco, Joanna project of Aurizon Mines and SEMAFO project in Guinea and Ghana;
4. I did the personal inspection of the Granada property in on November 2nd and 3rd 2011 and from November 27th to December 2nd of the same year, I also visited the property on March 14th, mid-April and July 4th 2012. In 2013, I visited the site on April 30th to May 2nd, from June 13th to 15th, from October 1st to 2nd. In 2014, I visited the site on January 12th to 14th, on January 24th, on February 13 to 14th, on February 26th to 28th and on May 20th to 24th;
5. I am responsible with the other author either singularly or jointly for the whole report of: " Technical Report, Technical Report, Prefeasibility Study (PFS) Phase I – Open Pit Granada Gold Project, Rouyn-Noranda " dated June 19th 2014 with the exception of section 20";
6. I am an independent "qualified person" within the meaning of National Instrument 43-101 – Standards of Disclosure for Mineral Projects of the Canadian Securities Administrators;
7. I have had no prior involvement with the property that is the subject of this technical report. I certify that there is no circumstance that could interfere with my judgment regarding the preparation of this technical report;
8. I have read NI 43-101 and Form 43-101F1 and have prepared and read the report entitled: Technical Report, Prefeasibility Study (PFS) Phase I – Open Pit Granada Gold Project, Rouyn-Noranda" dated June 19th 2014 for Gold Bullion Development Corporation in compliance with NI 43-101 and Form 43-101F1;
9. That, at the effective date of this technical report, to the best of my knowledge, information, and belief, for this Report with the exception of section 20, contains all scientific and technical information that is required to be disclosed to make the technical report not misleading.

Signed at Quebec this June 19th, 2014

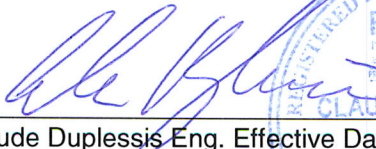
Claude Duplessis Eng. Effective Date: May 6th 2014

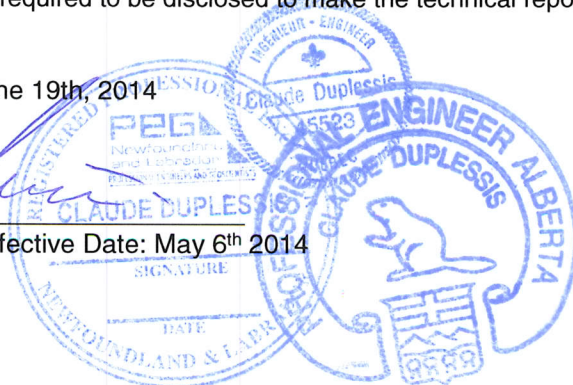

CERTIFICATE OF QUALIFIED PERSON

I, Gilbert Rousseau, Eng., of Ville de Saguenay, Province of Quebec, do hereby certify that:

1. I, Gilbert Rousseau, am a Senior Mining-Metallurgical Engineer with SGS Canada Inc., with a business address at 10 Boul. de la Seigneurie, Blainville, Quebec, J7C 3V5;
2. This certificate is to accompany the Report entitled: "Technical Report, Prefeasibility Study (PFS) Phase I – Open Pit Granada Gold Project, Rouyn-Noranda" dated June 19th 2014;
3. I graduated from The Ecole Polytechnique of the University of Montreal (B.Sc.A, Mining Engineer in 1969). I am a member in good standing of the "l'Ordre des Ingénieurs du Québec" (#20288). My relevant experience includes more than 40 years of experience in the mining and milling of minerals including iron, copper, lead, zinc, silver, gold, asbestos, graphite, nickel, silica, etc. I am a "Qualified Person" for the purposes of National Instrument 43-101 (the "instrument");
4. I visited the property on November 2nd and 3rd, 2011 and October 1st and 2nd, 2013;
5. I am responsible for sections 13 and 17 of this Report;
6. I am an independent "qualified person" within the meaning of National Instrument 43-101 – Standards of Disclosure for Mineral Projects of the Canadian Securities Administrators;
7. I was previously involved with that property, having written a "Certificate of Authorization" for a former mining company (RSW-BEROMA);
8. I have read NI 43-101 and Form 43-101F1 and have prepared and read the report entitled: Technical Report, Prefeasibility Study (PFS) Phase I – Open Pit Granada Gold Project, Rouyn-Noranda" dated June 19th 2014 for Gold Bullion Development Corporation in compliance with NI 43-101 and Form 43-101F1;
9. That, at the effective date of this technical report, to the best of my knowledge, information, and belief, for sections 13 and 17 of this Report, contains all scientific and technical information that is required to be disclosed to make the technical report not misleading.

Signed in Blainville, Quebec this June 19th, 2014



Gilbert Rousseau, Eng., Effective Date: May 6th 2014

CERTIFICATE OF QUALIFIED PERSON

I, Jonathan Gagne, Eng., MBA, do hereby certify that:

1. I am an Engineer with SGS Canada Inc. – Geostat with an office at 10, Blvd de la Seigneurie East, Suite 203, Blainville, Quebec, Canada, J7C 3V5;
2. This certificate is to accompany the Report entitled: "Technical Report, Prefeasibility Study (PFS) Phase I – Open Pit Granada Gold Project, Rouyn-Noranda" dated June 19th 2014;
3. I am a graduate of the École Polytechnique de Montréal (B.Sc. Mining Engineer, in 2007) and of the Université du Québec à Montréal (MBA, in 2013). I am a member of good standing, No. 146075, of the l'Ordre des Ingénieurs du Québec (Order of Engineers of Quebec). My relevant experience includes working as a mine planning engineer for a gold mining company and working as a consulting engineer to evaluate the potential of various mining projects. I am a "Qualified Person" for purposes of National Instrument 43-101;
4. I have visited the site on December 21st 2012 and on October 4th 2013;
5. I am responsible for the preparation of sections 15, 16 (at the exception of 16.1), 18, 21 and 22 of this technical report;
6. I am an independent "qualified person" within the meaning of National Instrument 43-101 – Standards of Disclosure for Mineral Projects of the Canadian Securities Administrators;
7. I have had no prior involvement with the property that is the subject of this technical report. I certify that there is no circumstance that could interfere with my judgment regarding the preparation of this technical report;
8. I have read NI 43-101 and Form 43-101F1 and have prepared and read the report entitled: Technical Report, Prefeasibility Study (PFS) Phase I – Open Pit Granada Gold Project, Rouyn-Noranda" dated June 19th 2014 for Gold Bullion Development Corporation in compliance with NI 43-101 and Form 43-101F1;
9. That, at the effective date of this technical report, to the best of my knowledge, information, and belief, for sections 15, 16, 18, 21 and 22 of this Report, contains all scientific and technical information that is required to be disclosed to make the technical report not misleading.

Signed in Blainville, Quebec this June 19th, 2014

Jonathan Gagné, Eng., MBA Effective Date: May 6th 2014

Certificate of Qualified Person

I, Martin Stapinsky, P. Geo., M.Sc., Ph.D., do hereby certify that:

1. I, Martin Stapinsky, am a Professional Geologist, employed as Project Manager - Environment at Roche Ltd, Consulting-group with an office at 630, Rene-Levesque Blvd West, Suite 1500, Montreal, Quebec, Canada, H3B 1S6;
2. This certificate is to accompany the Report entitled: "Technical Report, Prefeasibility Study (PFS) Phase I – Open Pit Granada Gold Project, Rouyn-Noranda" dated June 19th 2014;
3. I am a registered Professional Geologist (registration number 794) in Quebec, Canada. I graduated from the University of Montreal, Canada, with an B.Sc. Degree in Geology in 1989; from Laval University, Canada, with a M.Sc. Degree in Geology in 1991; from the University of Ottawa, Canada, with an Ph.D. Degree in Earth Sciences in 2001; and from l'École Nationale d'Administration Publique, Canada, with an M.Sc. Degree in Public Administration (International) in 2009. I have practiced my profession for 22 years in consulting and research. My relevant experience for the purpose of the Technical Report is: Over 10 years of consulting in the field of environmental issues in mining. As a result of my experience and qualifications, I am a "Qualified Person";
4. I did not visit the Granada Project property;
5. I have been directly involved in the Project in the analysis of environmental data, and the writing and review of Chapter 20 of: " Technical Report, Technical Report, Prefeasibility Study (PFS) Phase I – Open Pit Granada Gold Project, Rouyn-Noranda " dated June 19th;
6. I am an independent "qualified person" within the meaning of National Instrument 43-101 – Standards of Disclosure for Mineral Projects of the Canadian Securities Administrators;
7. I have had no prior involvement with the property that is the subject of this technical report. I certify that there is no circumstance that could interfere with my judgment regarding the preparation of this technical report;
8. I have read NI 43-101 and Form 43-101F1 and have prepared and read the report entitled: Technical Report, Prefeasibility Study (PFS) Phase I – Open Pit Granada Gold Project, Rouyn-Noranda" dated June 19th 2014 for Gold Bullion Development Corporation in compliance with NI 43-101 and Form 43-101F1;
9. That, at the effective date of this technical report, to the best of my knowledge, information, and belief, for sections 20 of this Report, contains all scientific and technical information that is required to be disclosed to make the technical report not misleading.

Signed at Montreal this June 19th, 2014



Martin Stapinsky, P. Geo., M.Sc., Ph.D. Effective Date: May 6th 2014



Appendix-2:

Processing

I- Crushing – Grinding –Gravity Main Process Equipment

II- CIL – CIP Circuit Main Process Equipment

III- Carbone Elution – Refining Main Process Equipment

IV- Cyanide Destruction – Desulfuration & Tailings Main Process Equipment

CRUSHING - GRINDING - GRAVITY MAIN PROCESS EQUIPMENT

- | | | | |
|-------------------|-------------------------|----------------------------|--------------------------|
| 05 - GRIZZLY | 30 - COARSE ORE BINS | 55 - CYCLONES | 80 - SHAKING TABLE |
| 10 - HOPPER | 35 - CONVEYOR | 60 - PUMP BOXES | 85 - BALL MILL (1000 HP) |
| 15 - APRON FEADER | 40 - SAG MILL (2700 HP) | 65 - SRL PUMPS | 90 - 27 m THICKENER |
| 20 - JAW CRUSHER | 45 - PUMP BOX | 70 - CYCLONES | 95 - SRL PUMP |
| 25 - CONVEYOR | 50 - SLURRY PUMPS | 75 - KNELSON CONCENTRATORS | 100 - WATER PUMP |

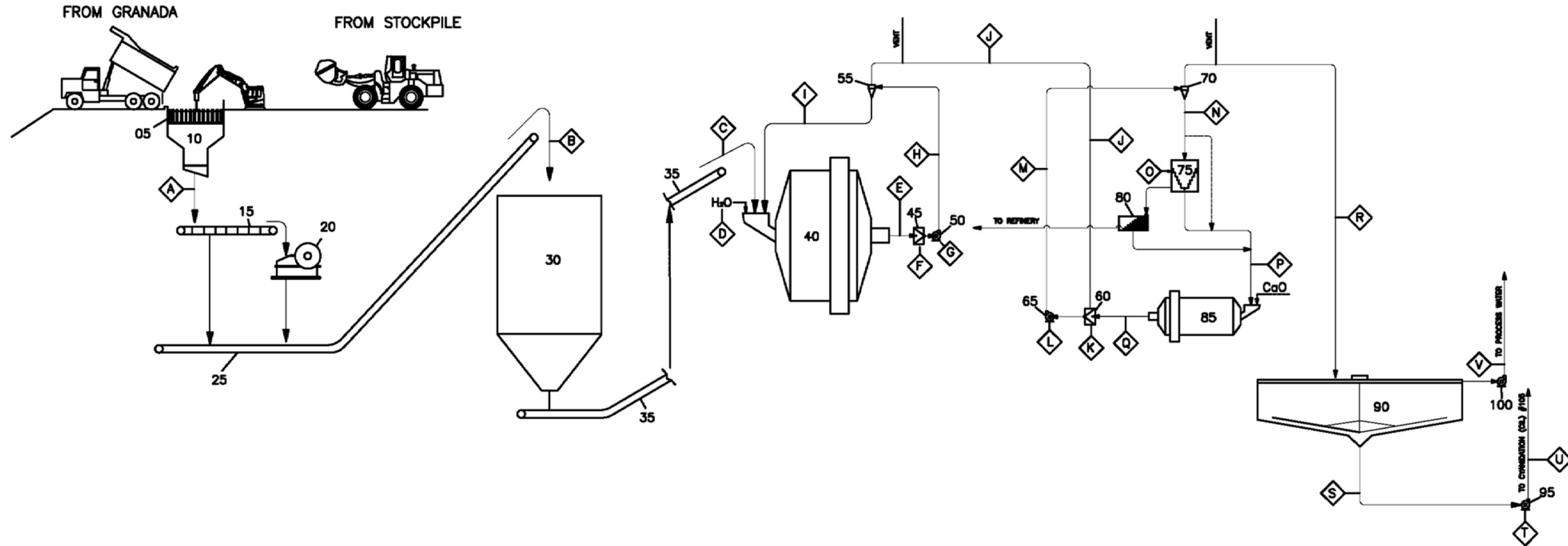

	A	B	C	D	E	F	G	H	I	J	K	L	M	N	O	P	Q	R	S	T	U	V
ORE Tonne/H	300	300	100		300			300	200	100			300	200		200	200	100	100		100	
% Solid	97.0	97.0	97.0		70.0			55.0	70.0	38.5			51.2	70.0		61.6	61.6	33.3	60.0		59.6	
ORE Sp. Gr.	2.78	2.78	2.78		2.78			2.78	2.78	2.78			2.78	2.78		2.78	2.78	2.78	2.78		2.78	
H ₂ O M ³ /H	9.27	9.27	3.09	39.8	128.6	115.9	1.0	245.5	85.7	159.8	0.0	1.0	285.9	85.7	39.0	124.7	124.7	200.2	66.7	1.0	67.7	133.5
Pulp M ³ /H					236.5			353.4	157.6	195.8			393.8	157.6		196.6	196.6	236.2	102.7		103.7	
Pulp Sp. Gr.					1.81			1.54	1.81	1.33			1.49	1.81		1.65	1.65	1.27	1.62		1.62	
H ₂ O USGPM	40.8	40.8	13.6	175.2	565.7	510.0	4.4	1080	377.1	703.1			1258	377.1	171.6	548.6	548.6	880.9	293.3	4.4	297.9	587.4
Pulp USGPM					1040			1555	693.6	861.4	0.0	4.4	1733	693.6		865.2	865.2	1039	451.8		456.2	
Au g/t	4.24	4.24	4.24		4.24			4.24	4.24	4.24			2.12	2.12		2.12	2.12	2.12	2.12		2.12	

DATE EMISSION ISSUE DATE		SGS	PROJECT PROJECT CLIENT	TITRE/TITLE
DESSINÉ PAR DRAWN BY	Gilbert Rousseau	Gold Bullion Development Corp.	P2013-15	2000 TPD IAMGOLD Schematic Flowsheet for the Granada Ore (Crushing - Grinding - Gravity)
VERIFIÉ PAR CHECKED BY	Frank Basa			No PROJ PROJECT No
APPROUVÉ PAR APPROVED BY				P2013-15
CIRCUL	SIGNATURE/SIGNATURE			No DESSIN DRAWING No
				GR 2014-01
	APPROBATION / APPROVAL			CONCU LE / DESIGN DATE
				REV./ REV.
				1
				FEUILLE / SHEET
				1/1

THE INFORMATION HEREON IS THE PROPERTY OF SGS CANADA INC. AND MUST BE RETURNED UPON REQUEST. ANY COPYING TRANSMITTAL TO OTHERS AND ANY USE EXCEPT THAT FOR WHICH IT IS LOANED ARE PROHIBITED WITHOUT WRITTEN PERMISSION.
L'INFORMATION CI-CONTENUE EST LA PROPRIÉTÉ DE SGS CANADA INC. ET DOIT LUI ÊTRE RETOURNÉ SUR DEMANDE. TOUTE TRANSMISSION DE COPIE(S) À AUTRUI ET TOUTE UTILISATION AUTRE QUE CELLE POUR LAQUELLE L'INFORMATION EST PRÊTÉE SONT INTERDITES SANS AUTORISATION ÉCRITE PRÉALABLE.

CIL - CIP CIRCUIT MAIN PROCESS EQUIPMENT

- 105 - 412 m³ CIL TANK
- 110 - 420 m³ CIL TANK
- 115 - 397 m³ CIL TANK
- 120 - 397 m³ CIL TANK
- 125 - 407 m³ CIL TANK
- 130 - SCREEN
- 135 - PUMP BOX
- 140 - SRL PUMPS
- 145 - 1492 m³ CIL TANK
- 150 - 1492 m³ CIL TANK
- 155 - 1492 m³ CIL TANK
- 160 - 1492 m³ CIL TANK
- 165 - 1493 m³ CYANIDE DESTRUCTION SURGE TANK
- 170 - PUMP BOX
- 175 - SRL PUMPS
- 180 - 462 m³ CIP TANK
- 185 - 432 m³ CIP TANK
- 190 - 437 m³ CIP TANK
- 195 - 352 m³ CIP TANK
- 200 - 337 m³ CIP TANK
- 205 - SAFETY SCREEN

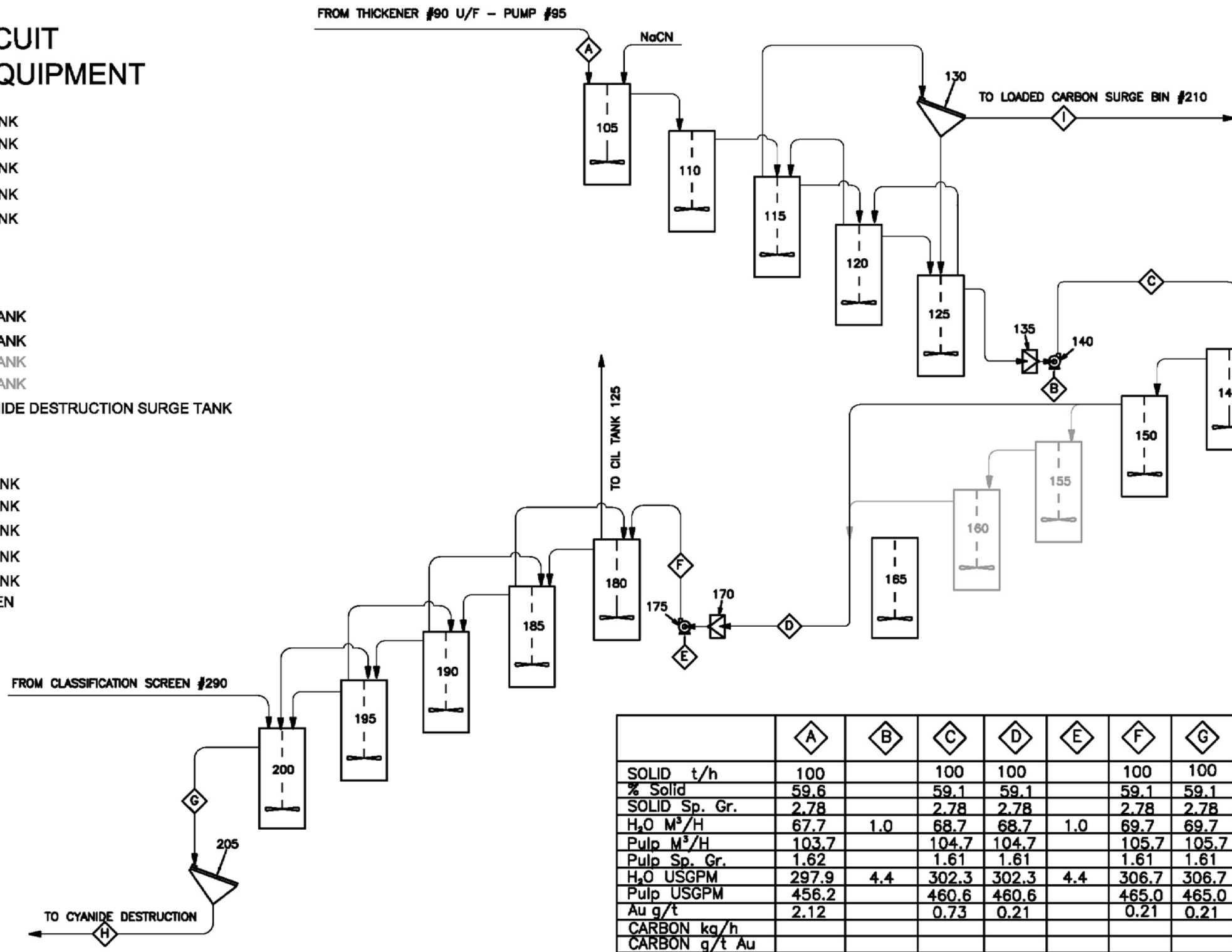

DATE ÉMISSION ISSUE DATE		 Gold Bullion Development Corp.	PROJET PROJECT CLIENT	P2013-15 2000 TPD IAMGOLD Schematic Flowsheet for the Granada Ore (Cil - Cip Circuit)	
DESSINÉ PAR DRAWN BY	Gilbert Rousseau		May 30 2014		No PROJ PROJECT No
VERIFIÉ PAR CHECKED BY	Frank Basa				P2013-15
APPROUVÉ PAR APPROVED BY					No DESSIN DRAWING No
CIRCUL	SIGNATURE/SIGNATURE	DATE		GR 2014-02	
APPROBATION / APPROVAL				CONCLU LE / DESIGN DATE	
				REV./ REV.	
				FEUILLE / SHEET	
				1 / 1	

THE INFORMATION HEREON IS THE PROPERTY OF SGS CANADA INC. AND MUST BE RETURNED UPON REQUEST. ANY COPYING TRANSMITTAL TO OTHERS AND ANY USE EXCEPT THAT FOR WHICH IT IS LOANED ARE PROHIBITED WITHOUT WRITTEN PERMISSION.
 L'INFORMATION CI-CONTENUE EST LA PROPRIÉTÉ DE SGS CANADA INC. ET DOIT LUI ÊTRE RETOURNÉ SUR DEMANDE. TOUTE TRANSMISSION DE COPIE(S) À AUTRUI ET TOUTE UTILISATION AUTRE QUE CELLE POUR LAQUELLE L'INFORMATION EST PRÊTÉE SONT INTERDITES SANS AUTORISATION ÉCRITE PRÉALABLE.

CARBON ELUTION-REFINING MAIN PROCESS EQUIPMENT

210 - LOADED CARBON SURGE BIN
215 - ACID WASH VESSEL
220 - ACID WASH CARBON PUMP
225 - CARBON STRIP VESSEL
230 - HEAT EXCHANGER
235 - HOT WATER PUMP

240 - PREGNANT SOLUTION TANK
245 - ELECTROWINNING CELLS
250 - OVEN
255 - INDUCTION FURNACE

260 - BARREN SOLUTION TANK
265 - CARBON DRAIN SCREEN
270 - REACTIVATION KILN
275 - QUENCH TANK
280 - TRANSFER PUMP

285 - STRIPPED CARBON TANK
290 - CLASSIFICATION SCREEN
295 - EDUCTOR WATER TANK
300 - PUMP
305 - FINE CARBON FILTER PRESS
310 - FRESH CARBON BIN

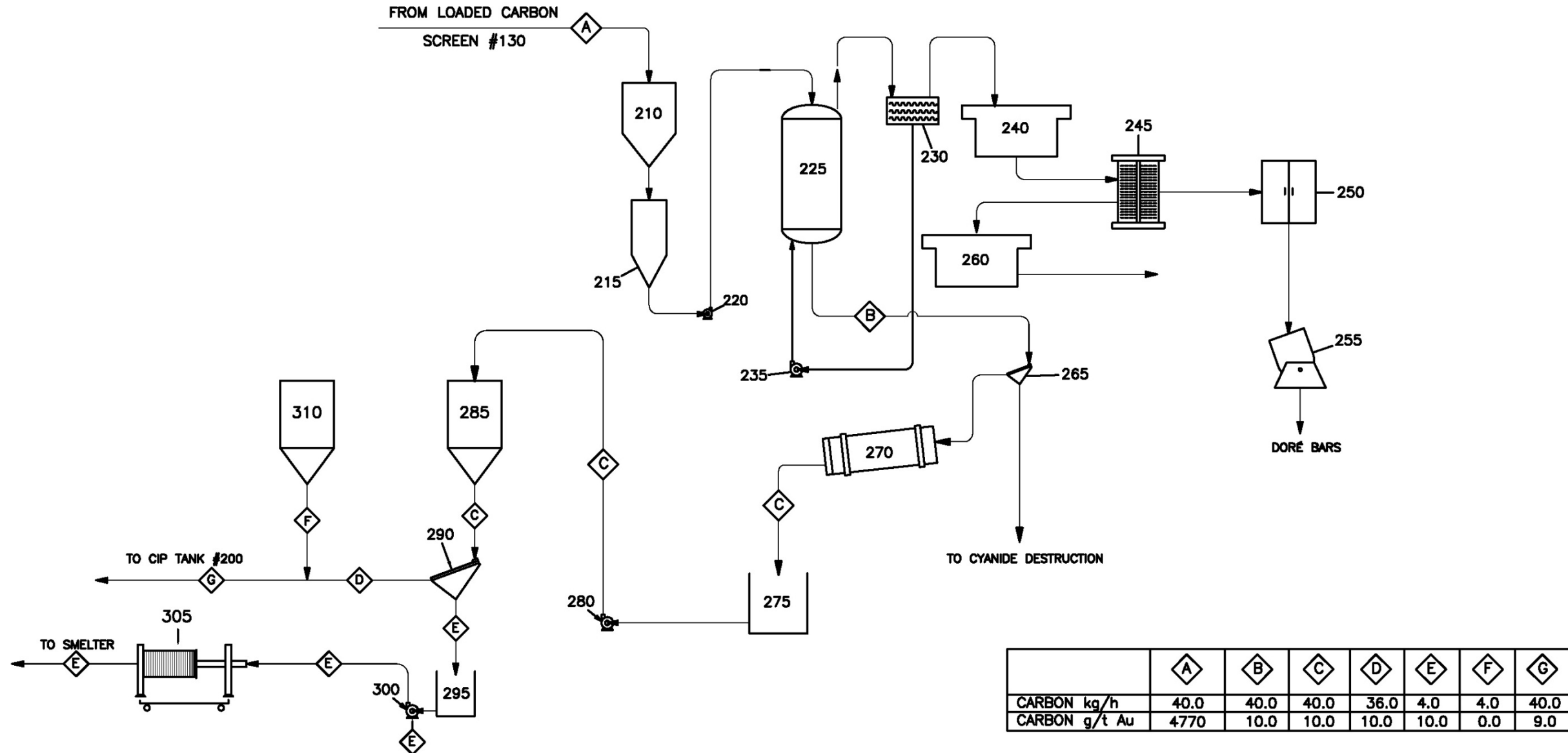

	A	B	C	D	E	F	G
CARBON kg/h	40.0	40.0	40.0	36.0	4.0	4.0	40.0
CARBON g/t Au	4770	10.0	10.0	10.0	10.0	0.0	9.0

DATE ÉMISSION ISSUE DATE			PROJET PROJECT CLIENT	P2013-15 Gold Bullion Development Corp.	TITRE/TITLE	2000 TPD IAMGOLD Schematic Flowsheet for the Granada Ore (Elution - Refining)			
DESSINÉ PAR DRAWN BY	Gilbert Rousseau		May 30 2014			No PROJET PROJECT No	P2013-15	 	CONCLU LE / DESIGN DATE
VERIFIÉ PAR CHECKED BY	Frank Basa					No DESSIN DRAWING No	GR 2014-03	REV./ REV.	FEUILLE / SHEET
APPROUVÉ PAR APPROVED BY						ECHELLE SCALE	FORMAT SIZE	0	1/1
CIRCUL	SIGNATURE/SIGNATURE	DATE	THE INFORMATION HEREON IS THE PROPERTY OF SGS CANADA INC. AND MUST BE RETURNED UPON REQUEST. ANY COPYING TRANSMITTAL TO OTHERS AND ANY USE EXCEPT THAT FOR WHICH IT IS LOANED ARE PROHIBITED WITHOUT WRITTEN PERMISSION. L'INFORMATION CI-CONTENUE EST LA PROPRIÉTÉ DE SGS CANADA INC. ET DOIT LUI ÊTRE RETOURNÉ SUR DEMANDE. TOUTE TRANSMISSION DE COPIE(S) À AUTRUI ET TOUTE UTILISATION AUTRE QUE CELLE POUR LAQUELLE L'INFORMATION EST PRÊTÉE SONT INTERDITES SANS AUTORISATION ÉCRITE PRÉALABLE.						
APPROBATION / APPROVAL									

CYANIDE DESTRUCTION – DESULFURATION & TAILINGS MAIN PROCESS EQUIPMENT

- 315 – PUMP BOX
- 320 – SRL PUMP
- 325 – 250 m³ CYANIDE DESTRUCTION TANK
- 330 – PUMP BOX
- 335 – SRL PUMP
- 340 – MILK OF LIME SURGE TANK
- 345 – PUMP
- 350 – SODIUM BISULFITE SURGE TANK
- 355 – PUMP
- 360 – COPPER SULFATE SURGE TANK
- 365 – PUMP
- 370 – AIR BLOWER
- 375 – COPPER SULFATE CONDITIONER TANK
- 380 – PAX + MIBC CONDITONER TANK
- 385 – PUMP BOX
- 390 – SRL PUMP
- 395 – ROUGHER 20 m³ UNIT CELL
- 400 – SCAVENGER DR 180 FLOTATION CELLS
- 405 – FINAL TAILINGS PUMP BOX
- 410 – FINAL TAILINGS SRL PUMPS
- 415 – PUMP BOX
- 420 – SRL PUMPS
- 425 – SUBMERSIBLE WATER PUMPS
- 430 – PROCESS WATER TANK
- 435 – WATER PUMP

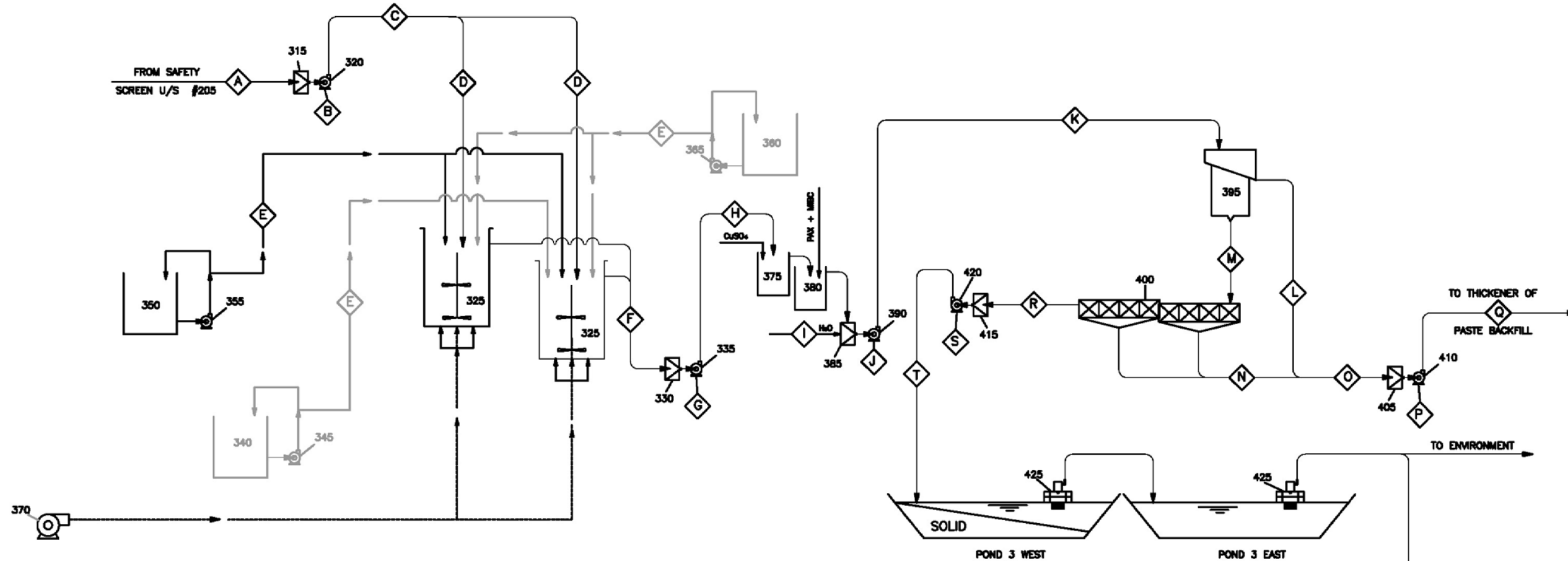

	A	B	C	D	E	F	G	H	I	J	K	L	M	N	O	P	Q	R	S	T
Solid Tonne/h	100		100	50.0		100		100			100	3.38	96.6	1.68	5.06		5.06	94.9		94.9
% Solid	59.1		58.7	58.7		57.5		57.2			40.7	40.7	40.7	40.7	40.7		37.2	40.7		40.5
Solid Sp. Gr.	2.78		2.78	2.78		2.78		2.78			2.78	3.50	2.78	3.50	3.50		3.50	2.78		2.78
H ₂ O M ³ /H	69.7	1.0	70.7	35.4	1.0	73.7	1.0	74.7	70.0	1.0	145.7	4.92	140.6	2.46	7.37	1.0	8.37	138.2	1.0	139.2
Pulp M ³ /H	105.7		106.7	53.4		109.7		95.3			181.7	5.88	175.7	2.94	8.82		9.82	172.8		148.9
Pulp Sp. Gr.	1.61		1.60	1.60		1.58		1.58			1.35	1.41	1.36	1.41	1.41		1.41	1.35		1.35
H ₂ O USGPM	308.7	4.4	311.1	155.6	4.4	324.3	4.4	328.7	308.0	4.4	641.1	21.6	618.9	10.8	32.4	4.4	36.8	608.0	4.4	612.4
Pulp USGPM	465.0		469.4	234.7		482.6		487.0			799.4	25.9	773.0	12.9	38.8		43.2	760.2		764.6
Au g/t	0.21		0.21	0.21		0.21		0.21			0.21	0.25	0.18	0.25	0.25		0.25	0.15		0.15

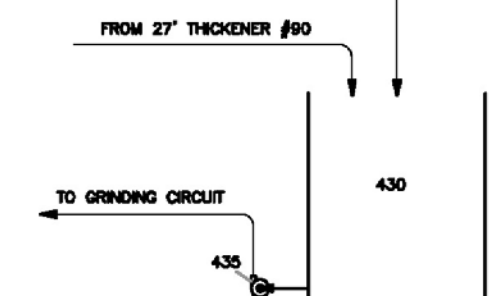

DATE ÉMISSION ISSUE DATE			PROJET PROJECT P2013-15	TITRE/TITLE 2000 TPD	
DESSINÉ PAR DRAWN BY	Gilbert Rousseau		CLIENT Gold Bullion Development Corp.	IAMGOLD Schematic Flowsheet for the Granada Ore Cyanide Destruction – Desulfuration – Tailings)	
VERIFIÉ PAR CHECKED BY	Frank Basa			No PROJET PROJECT No	P2013-15
APPROUVÉ PAR APPROVED BY				No DESSIN DRAWING No	GR 2014-04
CIRCUL	SIGNATURE/SIGNATURE	DATE	ECHELLE SCALE	FORMAT SIZE	
APPROBATION / APPROVAL				REV./ REV. 0	CONCLU LE / DESIGN DATE FEUILLE / SHEET 1/1

THE INFORMATION HEREON IS THE PROPERTY OF SGS CANADA INC. AND MUST BE RETURNED UPON REQUEST. ANY COPYING TRANSMITTAL TO OTHERS AND ANY USE EXCEPT THAT FOR WHICH IT IS LOANED ARE PROHIBITED WITHOUT WRITTEN PERMISSION.
 L'INFORMATION CI-CONTENUE EST LA PROPRIÉTÉ DE SGS CANADA INC. ET DOIT LUI ÊTRE RETOURNÉ SUR DEMANDE. TOUTE TRANSMISSION DE COPIE(S) À AUTRUI ET TOUTE UTILISATION AUTRE QUE CELLE POUR LAQUELLE L'INFORMATION EST PRÉTÉE SONT INTERDITES SANS AUTORISATION ÉCRITE PRÉALABLE.

